

A “QUICKGUIDE” TO INQUIRY-BASED PHYSICS LABORATORY REFORM

A Dissertation  
by  
JOHN COCKMAN

Submitted to the Graduate School  
Appalachian State University  
in partial fulfillment of the requirements for the degree of  
DOCTOR OF EDUCATION

December 2010  
Doctoral Program in Educational Leadership

A “QUICKGUIDE” TO PHYSICS LABORATORY REFORM

A Dissertation  
by  
JOHN COCKMAN  
December 2010

APPROVED BY:

---

Phillip Russell, Ph.D.  
Chairperson, Dissertation Committee

---

Patricia Allen, Ph.D.  
Member, Dissertation Committee

---

Michael Dale, Ph.D.  
Member, Dissertation Committee

---

Jon Saken, Ph.D.  
Member, Dissertation Committee

---

Jim Killacky, Ed.D.  
Director, Doctoral Program in Educational Leadership

---

Edelma D. Huntley, Ph.D.  
Dean, Research and Graduate Studies

Copyright by John Edward Cockman, Jr. 2010  
All Rights Reserved

## ABSTRACT

### A “QUICKGUIDE” TO PHYSICS LABORATORY REFORM (December 2010)

John Edward Cockman, Jr.,  
B.A., Appalachian State University  
M.S., Appalachian State University  
Chairperson: Phillip Russell, Ph.D.

Historically, students of introductory physics at Appalachian State University have posted low scores on a Force Concept Inventory-based Diagnostic Tool. In addition, semi-annual Student Laboratory Evaluation Forms indicate that students have generally exhibited poor attitudes toward the physics laboratories. Physics Education Research (PER) has demonstrated that these may be due in part to the cookbook nature of the laboratory activities. The purpose of this study was to test the effect of inquiry-based physics laboratories on student attitudes and diagnostic scores.

Because no prepackaged inquiry curriculum was found that matched Appalachian’s educational environment or course structure, Action Research was employed to redesign the introductory physics laboratory using an inquiry-based methodology. For two of the six algebra-based undergraduate laboratory sections, the traditional laboratory activities were replaced with a series of student-centered “QuickGuides” grouped by topical units. These activities were increasingly less guided as the two-semester sequence progressed. In addition to the reformed labs, the laboratory instructor and assistants employed Socratic dialogue in all interactions with students. These interventions significantly improved the attitudes and

behaviors of the students towards physics, as measured by the Colorado Learning Attitudes about Science Survey, Student Laboratory Evaluation Forms, and a video analysis of student-student and student-teacher interactions. It was also determined that the inquiry-based labs were effective in increasing the learning of students enrolled in a non-traditional, Modeling-based lecture section. However, there was no significant increase in scores on the Diagnostic Tool, or in the grades of students enrolled in two traditional lecture sections. Implications from the study, and suggestions for further research, are presented. Although overall results were positive, continued Action Research is necessary to improve the instructional materials and methodology that were developed over the course of this research.

## TABLE OF CONTENTS

Abstract.....	iv
Dedication.....	viii
Acknowledgments.....	ix
List of Tables and Figures.....	x
Preface.....	xi

### I: Introduction

Introduction.....	1
Problem Statement.....	6
Research Question.....	8
Summary of Methodology.....	9
Significance.....	10
Organization of Study.....	11
Glossary of Terms.....	14

### II: Literature

Timeline of Inquiry-Based Reform in Secondary Education.....	15
Post-Secondary Science Education Reform Efforts.....	24
Conceptual Framework.....	34

### III: Methodology

Methodological Approach.....	41
Research Question.....	42
Research Design.....	42
Design Rationale.....	48
Role of the Researcher.....	50
Ethical Issues.....	52
Trustworthiness.....	57
Participant Selection.....	61
Data Sources and Collection.....	64

### IV: Results

Introduction.....	74
Diagnostic Tool Results.....	74
Lecture Grade Results.....	76
CLASS Results.....	78
SLEF Results.....	81
EoCQ Results.....	84

Video Analysis.....	86
V: Discussion	
Introduction.....	88
Analysis.....	88
Revisiting the Conceptual Framework.....	95
Importance of Study.....	97
Limitations .....	99
Implications.....	99
Ongoing and Future Research.....	103
Works Cited .....	107
Works Consulted.....	130
Appendix A: Laboratory Report and Observation Grading Rubrics .....	136
Appendix B: Diagnostic Tool .....	140
Appendix C: Colorado Learning Attitudes about Science Survey .....	149
Appendix D: CLASS Thematic Groupings .....	152
Appendix E: Student Laboratory Evaluation Forms.....	153
Appendix F: End of Course Questionnaire.....	155
Appendix G: Video Recordings Observations.....	156
Appendix H: QuickGuides.....	172
Biographical Sketch.....	316

## DEDICATION

Dr. Andrew Jackson Graham was an Adjunct Physics Professor and Director of Laboratories at Appalachian State, a founding member of the Physics Instructional Resource Association (PIRA), the owner and moderator of the Teaching Apparatus Listserv (TAP-L), and a recipient of the American Association of Physics Teachers (AAPT) Distinguished Service Citation, but in the fall of 1995 I knew him only as my ornery physics laboratory instructor. Early that semester, I decided to drop out of school and look for a job. After a week of absences, I happened to bump into Andy on the school mall where I was hanging out with some friends, and he asked me where I had been. When I told him I wasn't coming back, he confronted me with immediate and surprising intensity, delivering an impassioned mini-lecture on the value of an education and the tragedy of wasted opportunities. He told me, in no uncertain terms, that he expected me back in lab that very week. Andy's display of concern and compassion floored me. I did come back, finishing the semester on the Dean's list for the first time ever and remaining there until graduation. Andy and I developed a strong student-mentor relationship, and after graduation he offered me a job as his assistant. He continued to teach and mentor me as I began taking classes toward a Master's Degree in Engineering Physics, and he strongly encouraged and supported me when I told him of my desire to pursue a Doctorate in Educational Leadership. His philosophy was one of continued education, even proclaiming on a bumper sticker: "The Truly Educated Never Graduate." Andy passed away on March 29, 2008, after a lengthy battle with cancer, leaving me with a deep sadness. I would give anything for him to be here as I finally complete this stage of the journey.



## ACKNOWLEDGEMENTS

I would like to thank the members of my Physics Education Research group, Dr. Patricia Allen and Dr. Jon Saken, for your immeasurable aid and moral support. This project would not have been possible without your help. I would also like to thank my family, Jennifer, Arwen, and Lorien for your love and patience.

## LIST OF TABLES AND FIGURES

Table 1: Algebra-based laboratory and lecture teaching schedules .....	64
Table 2: Pre-test and post-test gains for the Diagnostic Tool.....	77
Table 3: Modeling-based lecture grades, categorized by laboratory section.....	79
Table 4: Traditional lecture grades, categorized by laboratory section .....	80
Table 5: CLASS Shifts in favorable and unfavorable attitudes and beliefs .....	81
Table 6: Favorable CLASS responses .....	82
Table 7: Unfavorable CLASS responses .....	83
Table 8: Results of the End-of-Course Questionnaire .....	87
Figure 1: The four stages of Cyclical Action Research .....	34
Figure 2: Flow of Action Research in this Study.....	43
Figure 3: Responses to the End-of-Course Questionnaire.....	86

## PREFACE

During the summer of 2008, I became the Director of Laboratories in the Department of Physics and Astronomy at Appalachian, a position which had been vacated by the untimely passing of my dear friend and colleague Dr. Andrew Jackson Graham, to whose memory this dissertation has been dedicated. Among my new job responsibilities was the development of new labs, and so I began researching physics laboratory design. Before long, I was immersed in the literature of Physics Educational Research (PER), which unilaterally endorses inquiry-based laboratory reform. Up to that point, the introductory physics laboratory at Appalachian State had been taught using a lab manual with many of the activities presented in a “cookbook” fashion (Royuk & Brooks, 2003), meaning that the activities are explicit, scripted, and require no understanding on the part of the student in order to complete the activity. The cookbook nature of the activities resulted in simplistic laboratory reports, which led to grade inflation. In an attempt to keep lab scores down, points were disproportionately deducted for minor technicalities unrelated to the goals of the laboratory.

Student Laboratory Evaluation Forms (SLEFs) completed by students of introductory physics at Appalachian State indicated that this type of assessment led students to believe that lab grades were based on picky and arbitrary criteria, not reflective of actual student learning, thereby leading to general student dissatisfaction with the laboratory. In addition, lecture content pacing varied widely from section to section. Because of this, the weekly laboratory often seemed disconnected from the time spent in lecture, further alienating and confusing the students. Furthermore, historical student laboratory evaluation data showed

that a large percentage of students felt that the laboratory was irrelevant and out of step with the lecture.

Students were also regularly posting very low normalized gains on the physics department's Diagnostic Tool, which is a pre/post-test that examines changes in student understanding of basic physics concepts. I began discussing the idea of physics laboratory reform with Dr. Patricia Allen, who would later become my research advisor and the first member of my dissertation committee. Dr. Allen teaches an algebra-based physics course using an experimental Modeling-based methodology (Hestenes, 1987). Modeling Physics differs from traditional lecture in that it strives to be more coherent and student-centered, involving students in hands-on experimentation, analysis, and presentation of data (Jackson, Dukerich & Hestenes, 2008). I was interested in changing our labs in a way that would augment her style of instruction. As we talked about recent findings in Physics Educational Research, I began to formulate a plan to teach two experimental sections of the introductory, algebra-based physics laboratory using some of the methods that had been developed over the last ten years of research in physics inquiry. Dr. Allen gave me ideas, advice, and a book by Arnold Arons (1996) called *Teaching Introductory Physics*. Since that day, she and I have collaborated on multiple papers, presentations, and grant proposals.

A year before, in the summer of 2007, Dr. Allen had attended the Activity-Based Project Faculty Institute (ABPFI) in Eugene Oregon, taught by David Sokoloff and Richard Thornton, authors of RealTime Physics (RTP) (Thornton, 1996) and Interactive Lecture Demonstrations (ILDs) (Sokoloff and Thornton, 1997). Dr. Allen was also planning to attend the 2008 summer meeting of the Activity-Based Project Faculty Institute at Dickinson College in Carlisle, PA, and recommended that I also attend. Since I still knew very little

about teaching inquiry-based physics, I felt that this workshop would probably be necessary for the research I would conduct that fall. I was excited to learn that the primary instructor for this week-long workshop would be Priscilla Laws, whose name I had come across time and time again during my research. She had co-authored, along with Thornton and Sokoloff, a comprehensive set of instructional materials called *The Physics Suite* (Sokoloff, Thornton, & Laws, 2004). This suite included *Workshop Physics* (WP), RTP, and ILD.

Thornton's RTP labs are designed to introduce an interactive-engagement methodology into the physics laboratory within the context of a traditional structuring of lectures and labs. When RTP is appropriately implemented, active learning infiltrates the course through the laboratory. Laws' WP, on the other hand, is a total inquiry takeover, where the very class structure is centered on the laboratory experience. WP was a totally new experience for me. Accustomed to a system where the lecture was almost totally disconnected from the laboratory, I was thrilled to experience an environment where the two were tightly interwoven. The lecture blended seamlessly with the laboratory activities, then to an interactive demonstration, then back to the laboratory again.

Returning to Appalachian, I was energized and eager to test some of these methods in my own department. As Director of Laboratories, I have a professional interest in improving the quality of our laboratory experience, and as a member of Appalachian's newly-formed physics education research group, I have an interest in studying the effect of inquiry-based reform in our undergraduate laboratory. As a doctoral student in Educational Leadership, I used this research as an opportunity to step out and take a greater leadership role in determining the direction of our undergraduate laboratory curriculum. Using WP and RTP as

models, I began to explore ways to implement this type of inquiry-based instruction at Appalachian.

## CHAPTER 1: INTRODUCTION TO INQUIRY-BASED REFORM

Many PER studies indicate that conventional instruction fails to achieve the desired objectives for students (Laws, 1997; Liu, 2006; Redish & Steinberg, 1999; van Zee, Hammer, Bell, Roy, & Peter, 2005). These studies find that students are disengaged by subject matter that is cold and uncontextualized, leading to poor student understanding, low cognitive engagement, and rote learning (Kalman, 2002; Kubli, 2001; Stinner, 2006). Many students leave introductory courses unable to reason qualitatively about physical processes. They use primitive, formula-centered problem-solving techniques, their minds merely retaining “a small number of facts and equations that are accessible only by random searches” (Van Heuvelen, 1991, p. 891).

It is well-established in education research that active-learning instructional methods engender greater mental engagement and more extensive student-student and student-instructor interaction than does typical lecture (Meltzer & Manivannan, 2002). It has also long been the consensus of the PER community that an inquiry-based approach to teaching physics is the best way to address student misconceptions and attitudes toward physics (Brown, 1989, Demchik & Demchik, 1970). A curriculum utilizing inquiry-based, open-ended laboratory exercises leads to better conceptual understanding of physical concepts and a more positive attitude about science among the students (McDermott & Redish, 1999). In science, inquiry is a cyclical pattern of making observations, framing a question, formulating and carrying out a plan of action, reflecting on an explanation for the evidence, then using

that evidence to formulate new questions. According to the National Science Education Standards (NSES),

Scientific inquiry refers to the diverse ways in which scientists study the natural world and propose explanations based on the evidence derived from their work.

Inquiry also refers to the activities of students in which they develop knowledge and understanding of scientific ideas, as well as an understanding of how scientists study the natural world. (National Research Council, 1996, p. 23).

Although the NSES were initially developed to impact physics teaching in high schools, these standards have also found their way into community colleges and four-year universities. The NSES emphasize process as well as content, and inquiry is seen as a fundamental part of this process. Through inquiry, students address a question by gathering data, formulating and testing conjectures, and by making inferences (Horton & Leonard, 2005). Although the NSES strongly recommend that science instruction at all levels should be well grounded in inquiry, little has changed in the way science has been taught. Lecture and textbooks are still the primary providers of science information for students, especially at the university level (McBride, Bhatti, Hannan, & Feinberg, 2004). For some teachers, the NSES represent a confirmation of what they have been doing for a long time. For others, the standards represent a significant departure from current curricula that requires fundamental changes in attitudes regarding what and how they teach and how their students learn (Harrington, 1997; McInnis et al., 1995).

The traditional laboratory has long been under fire by many critics who believe that any similarity between actual experimental work and the traditional physics laboratory is purely coincidental (Arons, 1993; Nissani & et al., 1994). In 1978, Richard White of Monash



University noted that traditional science education laboratories were “smoothly organized places where the unexpected is not intended to occur” (p. 385). The rationale of laboratory use was to give students the opportunity to handle equipment, observe basic science laws, experience the scientific process, and achieve knowledge of error analysis and the interpretation of data. However, students generally come out of science classes with little ability or understanding of how to use the scientific concepts presented to them. Highly structured laboratory work is not very useful to students because these practices do not allow the students to think and reason for themselves (Watson, Swain & McRobbie, 2004).

Students should be given freedom to explore, make observations, discover errors and make correlations on their own while still being guided by the teacher (Arons, 1993). The teacher could put forth the question “What would happen if...” and that becomes the basis for the experiments to follow. Guided by the teacher, the students would begin exploring ways to answer the question, building gradually on basic observations and then moving on to more complicated exercises as they become significant to the answering of the original question. It is important to note that the learning process is greatly inhibited if the teacher presents these activities prematurely or if the activity is done for the students. Student involvement in every level of the laboratory experience should always be a primary objective of the teacher (Assessment Performance Unit, 1988).

The laboratory can have an important role to play in enhancing and complementing the lectures (Khoon & Othman, 2004). In a laboratory setting where students are asked to predict the outcome and explain their predictions, they learn the value of analyzing a situation in terms of basic concepts. Students also “learn the advantage of simple reasoning over manipulating equations” (Leonard, Gerace, Dufresne, & Mestre, 1999, abstract). For

example, students who are given various combinations of same-value resistors in series and parallel are asked to rank them in order of total resistance. Many are surprised to find that, after performing the laboratory activities, they are able to do this quickly and accurately without going through the calculations of equivalent resistance.

The physics laboratory is intended to provide experience in the manipulation of instruments and materials, which, according to Trumper (2002), “is thought to help students in the development of their conceptual understanding” (p.222). Since laboratory work is widely seen as crucial in developing an understanding of the procedures of scientific inquiry, labs should seek to develop students’ understanding of scientific methods of inquiry and their ability to use these methods in their own investigations. Contrasted with a conventional physics lecture, students in the inquiry-based laboratory are actively involved in their learning, using hands-on experimentation and prediction. Instead of benignly accepting the lecturer’s explanation of physical phenomena, students are sketching predictions and discussing them in groups of two or three. Instead of copying diagrams from the blackboard, they are utilizing features of graphs they have just plotted to argue their points of view with their peers. Instead of quietly scribbling notes, they are asking questions and answering them themselves or with the help of fellow students. These strategies lead to a level of student involvement, success, and understanding that is rare in the traditional physics lecture (Thornton & Sokoloff, 1990).

Much of recent pedagogical physics laboratory research focuses on the dichotomy between inquiry-based labs and “cookbook” labs (Kanter, Smith, McKenna, Rieger, & Linsenmeier, 2003; Royuk & Brooks, 2003). The failure of traditional laboratories seems to be nowhere disputed, and models for inquiry-oriented labs in postsecondary introductory

physics are being developed at an increasing number of institutions (Wenning & Wenning, 2006). The result is an undergraduate laboratory that more closely resembles the actual process of science (Glagovich & Swierczynski, 2004; Hakkarainen, 2004), producing students who think like physicists, with an understanding of the scientific methods of inquiry and the ability to use these methods in their own investigations (Bryan, 2006; Trumper, 2002). Reformed physics laboratories now include aspects of peer instruction and collaborative learning, pre- and post-tests to measure student learning gains, Socratic dialogue and conceptual questions, improving students' readiness to communicate, and their ability to transfer knowledge or apply concepts to novel situations (Bollag, 2007; Cox & Junkin, 2002). According to a study by Bryan (2006), student examination responses show that "unguided inquiry laboratory investigations result in knowledge gains that are greater than those resulting from traditional laboratory methods" (p. 60).

As physics teachers, we are often guilty of thinking and doing while our students are watching and listening (Freire, 1993), forgetting somehow that science is learned through doing. Because we have become familiar with basic physical concepts, we are often unaware that many students have a view of the physical world that is based more on popular folklore than on sound science. Too frequently, we take for granted that our words will be readily absorbed by the listening students, when in actuality they should be doing and experiencing for themselves (Reiff, 2002). This is the most effective way to confront students' misplaced Aristotelian preconceptions (Gang, 1995).

For example, many students have the notion that a tossed object goes upward because the continued impetus of the initial toss. When the impetus of the toss "runs out," then the object will come to a stop and only then will it begin developing a downward acceleration.

This idea may be countered by allowing students to experiment with a tossed ball tracked by a motion detector that simultaneously displays position, velocity, and acceleration. Once it is demonstrated that the ball exhibits a constant downward acceleration from the instant it leaves the hand, the thinking of the student can begin to change.

To combat Aristotelian thinking, much time should be given to the development of kinematical models that offer students experience with everyday phenomena in a variety of contexts. The goal of the physics laboratory instructor should be to create an environment in which the student has the opportunity to become the scientist, taking full advantage of real-life experiences with activities designed to expand and challenge existing world views (Etkina, Murthy, & Zou, 2006). This is the environment that I experienced while at the ABPFI in Carlisle, PA.

### **Problem Statement**

After returning from my workshop at Carlisle, I began assessing whether WP or RTP could be implemented at Appalachian State. However, it soon became clear that our course structure was not amenable to these types of curriculum. Our formal-lecture teaching schedule was organized so that large classes (usually around 70 students) met with a professor for three, one-hour sessions per week for lecture. The laboratories were conducted in groups of 32 students with different laboratory instructors during a weekly, two-hour session. In contrast, the typical WP teaching schedule is organized such that small classes (up to twenty-four students) meet with a professor for three, two-hour sessions per week, and the laboratories are made available on nights and weekends and are staffed by undergraduate teaching assistants.

There were other problems with trying to teach WP and RTP under the constraints of the traditional lecture and laboratory schedule. First, the class sizes at Appalachian were too large to be amenable to the workshop style, mostly because of equipment limitations. And, since the lecture lasted only 50 minutes, there was limited time for questioning, student presentations, and personal guidance by the instructor. Another problem was with content. Traditionally our first-semester course in algebra-based physics covers a potpourri of topics. However, in order to make time for the development of inquiry skills in a WP course, content must be reduced and lecture time sacrificed. The front end of the WP course is usually heavily loaded with mechanics and kinematics. In fact, WP and RTP devote nearly twice as much time to mechanics as our traditional laboratory. Although Laws et al. (1999) supply ample valid reasons for this approach, this feature of WP seems to be a common obstacle to its implementation in many classrooms across the country. When Brent Royuk of Concordia University performed a study comparing a semester of WP to traditional labs, one lecture instructor observed:

It may be nice to spend three weeks developing Newton's Second Law and over five weeks with forces, but this is at the expense of a good coverage of momentum, and all mention of rotations, torque, and oscillations. To say that interactive-engagement labs do a great job of teaching forces is not really fair, since I could produce students expert at almost any topic if I spent five weeks on it. (Royuk, 2002, p. 57)

I knew that topics normally covered in our traditional lectures were not going to be easily sacrificed by the instructors in order to follow the topical schedule of WP and RTP. Also, our labs only met once each week for two hours, and there was just not enough lab time to do even half of the activities in the RTP workbooks. I soon realized that any inquiry-based

redesign of our traditional laboratory would have to be tailored specifically for our unique setting and curriculum. An informal survey (Cockman, 2008) of other laboratory managers and directors on the TAP-L listserv revealed that I was not the only one facing this problem. It seemed that the constraints of the traditional introductory topic coverage schedule, coupled with the system of large lecture halls and segregated laboratories, is a universal obstacle to the broad-based implementation of inquiry-based reform.

My goals were to create laboratory experiences that feature more interactive engagement by students; to select activities that are inquiry-based and build on departmental strengths and resources; to increase the level of student/student interaction and collaboration in the laboratory; to engage students in dialogue rather than giving them one-way instructions; and to reduce the topical disconnect between lab and lecture. The activities had to be done without a major program restructure, and must have enormous flexibility, conforming to existing educational constructs. It became clear that I would have to bypass prepackaged inquiry curriculums like WP and RTP and, instead, develop a system that would allow me to become the researcher, engaged in applied research into inquiry-based physics reform. My role as Director of Laboratories dictated that my area of research would be focused on the introductory physics laboratory, and so I began designing a system that would bring about inquiry-based reform in that particular setting.

### **Research Question**

*Is it possible to perform effective, inquiry-based reform research in a post-secondary undergraduate physics laboratory without a major restructuring of class size, meeting pattern, and content coverage?*

## **Summary of Methodology**

The purpose of this study was not to develop a formula for inquiry that other Laboratory Directors may then use as a curriculum. It was rather to develop a framework for inquiry that other Laboratory Directors may use as a model for their own Action Research, creating an inquiry-based curriculum that works in their own unique academic setting. In her Presidential Address to the National Association for Research in Science Teaching (NARST), Dorothy Gabel made the following statement about the need for more Action Research by teachers in higher education:

I feel that we need to make a greater effort to involve teachers in Action Research.

Teachers already know much about teaching--more than many of us do. But many are waiting to be invited to participate in research studies in which they examine students' preconceptions, or effective teaching strategies. It is through joint research studies that science instruction in the schools will improve, and we need to make a great effort in this regard. (Gabel, 1995)

Perhaps the most appropriate model for a cyclical investigative process by educational researchers is Action Research. Action Research is a methodology which revolves around the following basic sequence: Plan, act, observe, reflect, and plan again (Kemmis & McTaggart, 1988). It is a methodology that pursues action at the same time it researches outcomes. When the idea of performing research in the physics laboratory was brought up in a meeting of our PER group, it was decided that each week's instruction should be informed by what was learned from the previous week's implementation.

Of the six sections of algebra-based laboratories, two were chosen as the experimental population and the rest became the control. To the experimental group, inquiry was introduced in the form of topically-grouped activities called “QuickGuides.” Based on an initial list of goals and outcomes developed by our PER group, these guides were developed weekly, informed by topical coverage in lecture, desired course goals and outcomes, and information gained during the previous week’s observation and reflection.

The success of inquiry-based reform is often measured by the gain of students on standardized pre/post assessment tools and attitudinal surveys. In this study, student scores on an in-house Diagnostic Tool and the Colorado Learning Attitudes about Science Survey (CLASS) (Adams et. al, 2004a) were used to determine course gains. In order to analyze several aspects of inquiry that are specific to the physics laboratory, and to proffer data triangulation that would increase the credibility of the research, several other sources of information were included in this study. These included a Likert-type End-of-Course Questionnaire (EoCQ) and Student Laboratory Evaluation Forms (SLEFs). A comparison of overall lecture grades was made to determine whether any gains in the laboratory were making in impact in the classroom. Student/student and student/teacher interactions were evaluated using a brief analysis of video recordings, both of the experimental and the traditional laboratory sections. The methodology will be explored in depth in Chapter III.

### **Significance**

According to the National Science Foundation (NSF) (1993), the progressive agenda of science education reform, particularly the goal of promoting student inquiry, places substantial intellectual demands on teachers, many of whom find it difficult to negotiate the



tension between teaching inquiry and traditional content. This is because many teachers have not been trained in inquiry instruction, or do not have access to a science-by-inquiry curriculum which is formatted to their particular institution. This may help to explain the considerable resistance to a change in teaching style within the science community (Brainard, 2007; Sunal et al., 2001). Although the NSF report is speaking primarily to K-12 reform, these same obstacles stand in the way of post-secondary reform. If reform is to succeed, the education community must do more to appreciate and address these demands. (Hammer, 1999).

Although physics education research in the U.S. has progressed steadily toward scientific inquiry, classroom practice has not kept pace. In many ways, post-secondary physics laboratory and lecture has not changed since the early 1900s (McBride et. al, 2004). Beginning primarily with the National Science Education Standards (NSES), there has been considerable pressure on teachers to implement inquiry-based classroom reform. In this era of seemingly daily advances in cognitive science and neuroscience (Pandey, Srinivasan, & Gupta, 2008), we are finally beginning to understand how students process, store, and utilize information. Unfortunately, educational materials and practices are not aligned with this knowledge (National Research Council, 2000a), and there is a gap that currently exists between what is known about how people learn and the methods and materials educators currently use to teach (Classrooms as Laboratories, 2001). It is clear that further study in a variety of school contexts and environments is required to expand our understanding of what constitutes good teaching and learning in physics (Geelan, Wildy, Loudon, & Wallace, 2004).

This significance is better understood when considered in the context of the history of inquiry in the physics laboratory. The next chapter will track the progression of inquiry-based physics laboratory instruction from the 19<sup>th</sup> century until the present. Although there are literally hundreds of prescribed options for implementing reform, what seems to be missing in the literature of physics inquiry is one that relinquishes control to the practitioner, placing the instructor into the role of researcher, actively making decisions that affect content, timing, and course structure.

Although it is clear that hands-on experimentation benefits students (Houlden et al., 1983), we as teachers sometimes forget that we are also learners who benefit from immersive, hands-on practice. To quote John Dewey, “all genuine learning comes about through experience” (Ansbacher, 2000, p. 224). This study is significant in that it chronicles an attempt by a teacher to enact Action Research to bring about educational reform rather than trying to fit a round peg into a square hole using a prepackaged curriculum. The physics instructor is transformed from a teacher who is trying out a new curriculum into an inquiry investigator who is actively engaged in physics educational research.

### **Organization of Study**

The first chapter of this dissertation serves as an introduction to the issue of inquiry-based physics laboratory reform. It includes a problem statement, a brief summary of the methodology employed, and an argument for the significance of the study. A research question is proposed, and a link is established between Educational Leadership and the enactment of this type of inquiry-based laboratory reform at Appalachian State.

The second chapter gives a synopsis of the history of inquiry-based reform, and includes a succinct overview of the recent movement toward the ubiquitous implementation of inquiry-based curriculum in the college level physics course and laboratory. A review of the literature reveals a need for Action Research in the area of physics laboratory reform, and a conceptual framework for this study is formed. This framework is used to build a case for the methodology employed, and also outlines the assessment tools used to measure the success of the experiment.

The third chapter provides a description of the methodology employed in this study. The goals and outcomes of the experimental laboratories, along with creation of the grading rubrics (Appendix A), are discussed. The assessment tools are also detailed. These include the Departmental Diagnostic (Appendix B), the Colorado Learning Attitudes about Science Survey (Appendixes C and D), Student Laboratory Evaluation Forms (Appendix E), and the End of Course Questionnaire (Appendix F), as well as video recordings and instructor observations (Appendix G). Ethical issues and the role of the researcher are explored, and a case is made for the trustworthiness of the investigation. Participant selection and sources of data are detailed, and the collection, coding and analysis of data are discussed.

Chapters four and five report the findings and analyze the results of the study. Special considerations are given to the limitations of the design, and also how well the study addressed the gap identified in the first chapter. The conceptual framework is revisited, and the implications are discussed. Finally, suggestions for future research are presented.

## **Glossary of Terms**

**Action Research** – A cyclical methodology, revolving around the following basic sequence: Plan, act, observe, reflect, and plan again (Kemmis & McTaggart, 1988). It is a methodology which pursues action at the same time it researches outcomes.

**Confirmability:** A measure of how well an inquiry's findings are supported by the data collected (Lincoln & Guba, 1985).

**Data triangulation:** A validity procedure where researchers search for convergence among multiple and different sources of information to form themes or categories in a study (Creswell & Miller, 2000).

**Dependability:** An assessment of the quality of the integrated processes of data collection, data analysis, and theory generation.

**Inquiry-Based Reform** – A pedagogical approach to teaching which requires that learning should be based around student's questions.

**Likert-type survey** - A survey based on a response scale specifying the level of agreement to a statement. The scale is named after Rensis Likert, who published a 1932 report describing its use.

**QuickGuides** – A collection of inquiry-based activities developed by John Cockman and Patricia Allen to introduce inquiry-based reform into the physics labs at Appalachian State.

**Normalized Gain** – Developed by Richard Hake for describing gains on pre/post tests such as the FCI, normalized gain is the ratio of the actual gain to the maximum possible gain.

**Socratic Dialogue** – A form of inquiry between individuals that is based on asking and answering questions to engage students and stimulate critical thinking.

## CHAPTER II: LITERATURE

In this chapter a timeline of science education reform attempts will be examined. Reform began in high schools first, energized by several major catalyzing events including Sputnik and a technology race with Japan. With secondary education leading the way, reform slowly matriculated to colleges and universities. Inquiry-based physics was introduced at the college level by Arnold Arons, whose influence on Richard Hake ushered in a new era of inquiry-based reform built on solid physics education research. With mixed success, many curricula have now been developed to replace traditional physics laboratory and lecture instruction with an inquiry-based methodology. Many of these are outlined in this chapter. The chapter closes with a description of this study's conceptual framework, presenting Action Research as an appropriate method of implementing physics laboratory reform in the university setting today.

### **Timeline of Inquiry-Based Reform in Secondary Education**

Science education in the United States has evolved over the last two centuries from the transmission of science as a body of knowledge to a method of learning that directly involves the student. This method is commonly referred to as inquiry (Redish, 2000). The history of inquiry in this country has been relatively brief. Post-secondary science has traditionally been taught as lists of memorized facts, with only marginal opportunities given

to students for hands-on observations. In contrast, the study of science through inquiry uses a constructivist approach to challenge students to a deeper knowledge of scientific phenomena through active investigation (Educational Broadcasting Corporation, 2004).

In the 19<sup>th</sup> century, the majority of the U. S. population was still rural, with urban centers relatively small. Secondary schools were fairly new and only used by a privileged few. High schools and colleges offered practical subjects such as surveying, navigation, and astronomical calculations. By the mid-1800s, science curricula had expanded to include subjects in meteorology, botany, physiology and zoology, with physics not being added until later in the century (DeBoer, 1991). The college classes were taught as a set of facts through lecture only, containing very little laboratory work. What few laboratories were offered had little effect on student understanding except to render some manipulative skills (White, 1978). Many high schools were influenced greatly at this time by college science programs and entrance requirements, which gave little consideration to the scientific process or student interest (Domin, 1999). Lectures were given straight from the textbook with little thought for laboratory work. The scientific process was hardly shown to the science students of this time nor was there significant reflection given to investigative work (Chiappetta, 2008). Though practical work was highly valued, little to no attention was given to improving laboratory instruction in order to bring about deeper scientific understanding (White, 1978).

The influence of higher education on the way science was taught in high school became a concern to several national secondary education committees by the end of the 19<sup>th</sup> century. One of these was the Committee of Ten (National Education Association, 1894), which sought to bring about changes by standardizing the high school curriculum and aligning programs through all grade levels. It was the position of this committee that high

school was not to be viewed as preparation for college. It contended that students should learn and apply the abilities they would need to perform in an industrial society instead of preparing solely for college science classes that were still centered around the lecture-style format (DeBoer, 1991). This movement would set the stage for a more independent secondary science curriculum which would, with the advent of the NSES, ultimately influence the way physics is taught in colleges.

The committee's actions had the desired effect of diminishing the control of college requirements on science courses in secondary schools, but these classes were not changed dramatically. The high school science programs that were being taught during this time were practical and geared toward training students to become productive members of society. Science was taught primarily through lecture, with very little exploration or investigation. National committee proposals and research literature were beginning to realize the significance of inquiry and the process of learning science through application (McBride, Bhatti, Hannan, & Feinberg, 2004). Assembling on the national level in 1915, the Central Association of Science and Mathematics Teachers asserted that students needed to be taught the process of acquiring scientific information rather than strictly accumulating knowledge through textbooks (NRC, 2000).

Influenced by the Committee of Ten, other committees and commissions began to push for inquiry-based science education. The Commission on the Reorganization of Secondary Education mandated that the following curriculum improvements should be incorporated into secondary science teaching: (1) health, (2) command of fundamental process, (3) worthy home membership, (4) vocation, (5) citizenship, (6) worthy use of leisure time, and (7) ethical character (Neumann, 1917, Caldwell, 1920). A 1924 report by the

Committee on the Place of Science in Education of the American Association for the Advancement of Science (AAAS) emphasized the importance of scientific thinking, as opposed to science memorization, as a goal of science teaching. This report urged moving science instruction toward an inquiry-based approach (Caldwell, 1924). The report also stressed the need for giving students a greater feel for scientific experience, not just scientific lecture. Experimentation and observation were given more importance and scientific thinking became a new goal for science teachers (Herron, 1971). The Commission on Secondary Curriculum of the Progressive Education Association published a report in 1934 emphasizing the value of linking everyday problems with science curriculum and using subject matter that would encourage logical thinking and provide practical uses in students' lives.

At this juncture, John Dewey (1859-1952) stepped forward to give his view on scientific inquiry and the practical expression of knowledge and problem solving. Dewey was an education reformer, philosopher, and psychologist who led the progressive education movement of the early 1900s. He had profound influence on the educational philosophies of the time through his extensive work at the University of Chicago Laboratory Schools. These schools were established for use as research facilities in educational reform and also as places to put Dewey's ideas into practice. He was not the first to believe that education is based wholly on experience. According to Dewey, many great thinkers of the past, including Socrates, Rousseau, and Kant, asserted that education is not the training for life, but life itself (Dewey, 1938). Dewey asserted that students learn best while doing, observing, and problem solving (Dewey, 1909). Learning, in his opinion, wasn't worth doing only for the sake of increasing knowledge. "In the order both of time and of importance, science as method precedes science as subject-matter... Only by taking a hand in the making of knowledge, by



transferring guess and opinion into belief authorized by inquiry, does one ever get a knowledge of the method of knowing” (Archambault, 1964 p. 188). He asserted that the right combination of laboratory work and book work were the key to unlocking the natural curiosity of students, allowing them to process new information through all levels of instruction (Ansbacher, 2000). According to Dewey, learning through inquiry is important not only to students, but to society as a whole. The development of individuals and the betterment of society must be the higher goals of education (Dewey, 1938).

After Dewey, and before the most recent wave of physics education research, there were two major thrusts of public awareness and outcry that pushed physics laboratory education toward a more inquiry-based model. These were the failure of the U.S.A. to beat the Soviet Union into space, and a race with Japan to develop new consumer technology. Though many national education committees supported the use of inquiry in education in the early 1900s, very little progress was made to implement inquiry-based education (Bybee, 2000). However, the social and political environment after World War II brought about many changes in science education in the United States. Due to economic and population growth, the need for schools significantly increased.

Scientific and technological advances were paramount as the U. S. entered into the Cold War with the Soviet Union. Leaders became alarmed at the condition of math and science courses in schools across the country, claiming that they “lacked rigor, were dogmatically taught, were content oriented, lacked conceptual unity, were outdated, and had little bearing on what was happening in the scientific disciplines” (Collette & Chiappetta, 1989, p. 11-12). Because of the remedial state of high school math and science, colleges found that students were inadequately prepared to study these subjects at the university level.

Slowly, curriculum changes began to appear. In 1957, the Soviet Union launched the world's first artificial satellite, Sputnik 1, an event that transformed American higher education, providing the stimulant needed to begin bringing about widespread curriculum changes in science and math (Brainard, 2007).

This event indicated to the American people that the U.S. education system had fallen behind, thus science and technology in this country were having trouble competing with the Russian technological advances (Brekke, 1995). Due to the seemingly scientific superiority of the Soviet Union, the United States experienced an explosion in government funding for high school science curriculum reform. Many researchers and education reformers of this time endeavored to replace the traditional cookbook style of science education with hands-on involvement and a greater concentration on logical thinking abilities (Watson, Swain & McRobbie, 2004).

Joseph Schwab (1909-1988) became a leading education reformer during the 1950s and 1960s, advancing the understanding of inquiry-based instruction and working to develop better curriculum. Schwab was a proponent of teaching students the methods used by scientists and the way science is explored. In a lecture titled “The Teaching of Science as Enquiry” in 1962, Schwab opposed many of the ideas concerning inquiry at the time, even insisting that his teaching style be spelled “enquiry” in order to highlight the difference. The laboratory was the primary learning tool for students of science, according to Schwab, and he encouraged science teachers to forgo the formal lectures and concentrate on laboratory and field work. After the students discovered basic scientific principles for themselves using hands-on techniques, then the more formal lectures could be used to further develop the students’ understanding (NRC, 2000). Since Schwab promoted the teaching of science

through investigation, the use of laboratories was a perfect solution. He wished to show students how scientists actually form ideas about science and then proceed to examine their ideas and discoveries (Eltinge and Roberts, 1993).

Schwab was very concerned that science not be taught as a creed or set of rules, but as an ever-changing and developing concept based on ideas, data collection, observations, and theories. He proposed that laboratory work should be done without laboratory or textbook-based questions, thus allowing the students to learn science through the process of assembling data, asking questions, and formulating explanations (NRC, 2000). The use of laboratory work was extremely important, in Schwab's view, to the understanding and critical thinking skills of all science students and he also emphasized the value of students examining the works of other scientists. Schwab was convinced that students, when given a wide range of credible material to work with, coupled with extensive laboratory work, could grasp science in a much deeper sense. He encouraged teachers to provide their students with scientific literature, experiments, historical documentation, conclusions, conflicting data, and alternate explanations, claiming that would give them the greatest understanding of scientific knowledge (Schwab, 1962).

Also drawn into the education debate at this time was Jean Piaget (1896-1980), recognized as a great pioneer of the constructivist theory of knowing (Von Glasersfeld, 1990). Piaget postulated that knowledge is constructed by assimilating new information in a way that connects with our current understanding. For example, a student who watches a marble drop might assume that a coffee filter would drop in the same manner. If new experiences do not align with current understanding, then the student must make an accommodation that then expands that student's sphere of knowledge. Piaget believed this

type of development, through experiences and challenges, brought about the highest stage of intellectual growth. According to Piaget, information learned by rote is soon forgotten, but learning accompanied by doing is forever imprinted on the mind (Piaget, 1983).

One of Piaget's contemporaries, Jerome Bruner, was asked to head the National Academy of Sciences curriculum reform group in 1957. His report became a best-selling book entitled *The Process of Education* that contained three key ideas to his education beliefs. These beliefs focused on 1) the structure of knowledge or how ideas come together, 2) Jean Piaget's thought that student understanding of an idea is based on the actual intellectual processes attained, and 3) the concept that mental skills must be applied to corresponding tasks (Bruner, 1960). Bruner had considerable influence on the progression of laboratory-based science education, and during this time period, the value of student involvement in the process of learning how to do science was emphasized in many books, papers, and articles (Driver and Easley, 1978, Chiappetta, 2008).

From the late 1970s and through the 1980s, values education and social concerns became key ambitions in a new education reform movement (Bryant & Marek, 1987). Rather than stressing pure science, teachers at both the high school and the college level put more emphasis on the social relevance of science and technology, creating a new balance in science education (DeBoer, 2000). Inquiry took a less important role in science education at this time. Despite this curriculum shift away from a more refined view of science, many scientists still felt that the laboratory was the key to greater understanding of science concepts. Due to its cost, however, many high school administrators did not feel that the laboratory was worth using, and experimental science took a back seat (Tamir, 1977). As a result, students were entering universities with little or no laboratory background.

In the 1980s, Japan became a primary contender in the world economy. The Japanese were advanced in technological and scientific achievements, particularly in electronics, automobile manufacturing, and steel working. This brought science education in the United States under condemnation once again because students were not prepared to enter a scientific and technological society (Gardner, 1983). This race, though economic in nature, had the same result as the threat of the Soviet Union's space program of the 1950s. It galvanized a new awareness of needed improvements in the education system of the United States and brought about another reformation. This was brought home to the American public when the National Commission on Excellence in Education put forth a report titled *A Nation at Risk* (Gardner, 1983). This report made the frightening claim that "our education system has fallen behind and this is reflected in our leadership in commerce, industry, science and technological innovations, which is being taken over by competitors throughout the world" (p. 9).

In response to public demand, a report by the AAAS entitled *Science for All Americans: Project 2061* (American Association for the Advancement of Science, 1990) emerged with the intent to reform K-12 science education in this country. Project 2061 set a goal of generating a scientifically knowledgeable culture by the year 2061, but gave no particular method that should be used for the teaching of science. In 1996, however, the National Research Council (NRC) released the National Science Education Standards (NSES) (National Research Council, 1996). The National Science Education Standards, representing the results of four years of work by twenty-two scientific and science education societies, and over 18,000 individual contributors, took the Project 2061 objectives and began to transform national K-12 standards to reflect the advantages of inquiry.

The NRC found that high school students who were taught facts could make calculations. However, if they were given few hands-on opportunities, they could not integrate disparate facts and apply concepts to other topics of study. As more investigative laboratory work was introduced to the students, the students showed a marked improvement in reasoning and logical thinking skills (NRC, 2000). The NSES promoted scientific literacy through social processes such as group discussion and experimentation in which student understanding is actively constructed. Students, therefore, develop an understanding of the natural world in the same way that scientists do: seeking answers to questions about the natural world while actively engaged in scientific inquiry (Bryant & Marek, 1987). This reformation of science education was a rejection of the traditional lecture model, in which students were receptors of knowledge that is disseminated by an expert professor, and required substantive changes in how science is taught (NRC, 1996).

### **Post-Secondary Science Education Reform Efforts**

Until the 1970s, inquiry-based reform efforts had taken place primarily in the K-12 curriculum. However, science education reform was making its way in to the university setting, albeit very slowly. In 1970, “A Study of the Inquiry-Discovery Method of Laboratory Instruction” by Richardson and Renner found that students in inquiry-applied labs performed significantly better on final lab exams than did students in traditional labs. Pavelich and Abraham (1977) performed a study evaluating the gains made by inquiry and traditional laboratory students in abstract thinking abilities and found that the inquiry group scored much higher than did the traditional lab group. R. M. Gagne (1968) postulated that in order for students to fully comprehend a subject matter, they must be able to understand a verbal

explanation and also experience the reason that subject matter is true or false. For example, a student studying latent heat may understand that a quantity of water will lose heat energy by vaporizing a quantity of liquid nitrogen, but this is purely academic until the student actually pours the cold liquid into a container of warm water. If the student does not associate the verbal knowledge with the intellectual skills, then they have learned by rote (Gagne & White, 1978).

One early leader in university science education reform was Arnold B. Arons of Harvard University. Greatly influenced by Socrates, Plato, Dewey, and Piaget, Arons was one of the founders of Physics Education Research (PER) in the United States. He performed extensive studies of the use of Socratic questioning in the science education environment in order to move students from a declarative knowledge to an operative knowledge.

Declarative knowledge consists of knowing “facts”; for example, that the moon shines by reflected sunlight, that the earth and planets revolve around the sun . . . .

Operative knowledge, on the other hand, involves understanding the source of such declarative knowledge. How do we know the moon shines by reflected sunlight? Why do we believe the earth and planets revolve around the sun when appearances suggest that everything revolves around the earth? (Arons, 1983)

Arons’ years of work and research led him to believe that teachers could bring students to a superior understanding of scientific knowledge if they incorporated Socratic questioning into their classes and laboratories. But questioning was not enough. The teacher must also listen attentively to students’ reactions and observations in order to guide them into new areas of reasoning and logical thinking (Hake, 2004). Inspired by Arons’ work (1972) using inquiry and Socratic questioning, George Kolodiy (1977) began programs that were

quite successful in implementing hands-on activities and Socratic questioning, greatly enhancing the students' logical thinking skills and reasoning abilities (Hake, 2004).

Shortly after *A Nation at Risk* was published in 1983, several physics professors from around the United States began to observe that students did not understand basic physical concepts even though they could perform the calculations. In 1985, Ibrahim Halloun and David Hestenes developed the Mechanics Diagnostic Test (MDT) at Arizona State University. This test was used to assess the readiness of high school students, and the effectiveness of college instruction. The researchers studied the "common sense" beliefs held by students about basic simple mechanical systems and they discovered that, in general, students' beliefs are not correct in terms of classical Newtonian understanding. (Halloun and Hestenes, 1985).

In order to address the shortcomings revealed by the MDT, Halloun and Hestenes, along with high school teacher Malcolm Wells, created a new method of instruction known as Modeling Instruction. With Modeling Instruction, students receive very little lecture time, but instead make and use models to describe, to explain, to predict, to design and control physical phenomena (Wells, Hestenes & Swackhamer, 1995). David Hestenes went on to revise the MDT and published this new test under the name Force Concept Inventory (FCI) (1992). The FCI is a pre/post-test showing how students' conceptions of Newtonian concepts change after instruction. It has become the most extensively used method of measuring student knowledge of classical physics concepts. When given before and after course completion, the FCI demonstrates a lack of change to common student misconceptions after receiving traditional lecture methods. The FCI also shows that students participating in



inquiry-based class settings demonstrate considerable progress in the understanding of physics concepts and reasoning abilities (Hake, 1992, Mazur, 1997).

Of particular interest is the work of Richard Hake (1992) in observing the advantages of using Socratic ideas in introductory physics labs where students were asked questions and then given elementary activities to help them discover answers for themselves. His development of Socratic Dialogue Inducing (SDI) lab methods, inspired by a telephone conversation in 1980 with Arnold Arons, brought hands-on experience to students while providing interaction between those students. University students were given lab manuals to work through, but if they had problems or questions, the laboratory instructor would not directly answer. Rather, the instructor would ask questions, in order to compel the students to greater logical thinking. By answering questions concerning the laboratory procedures, the students came to the answers through their own reasoning, thus the laboratory experience was greatly enhanced. (Hake & Tobias, 1988).

In a famous study, Hake evaluated the normalized gains of more than 6000 physics students who took the FCI. The normalized gain is the average increase in students' scores on the FCI divided by the average increase that would have resulted if all students had perfect scores on the post-instruction test. Hake found that traditional introductory physics courses received normalized gains of  $0.23 \pm 0.04$ . In contrast, the normalized gains earned by interactive-engagement courses are in the range  $0.48 \pm 0.14$ , a statistically (and educationally) significant difference (Hake, 1998).

Meanwhile, drawing from over 25 years of research in inquiry instruction at the University of Washington, Lillian McDermott established the *Physics by Inquiry* (PbI) program, which is based on workshop training sessions (McDermott, 1996). These PbI

classes have no lecture time and are completely guided/discovery laboratories. In 1989, Priscilla Laws introduced inquiry-based physics to a wider audience with the development of Workshop Physics (WP) (Laws, 1989). WP was a modified version of McDermott's PBI specifically for calculus-based physics (Laws, 1991). Through the NSF's Fund for the Improvement of Postsecondary Education (FIPSE) Interactive Physics Project (1993), she and Ronald Thornton encouraged instructors at large universities to forego lecture in favor of an integrated method. The trio developed a comprehensive set of instructional materials for inquiry curricula that later evolved into the Workshop Physics Suite. This suite includes Thornton's RealTime Physics (RTP) and Sokoloff's Interactive Lecture Demonstrations (ILDs).

Thornton (1996) had begun developing RTP in 1992 as a way to reorganize introductory physics course structures with workshops replacing traditional lectures and labs. Still very much in use today, RTP is a series of laboratory guides that focuses on conceptual and quantitative understanding through the use of Thornton's own Microprocessor-Based Laboratory (MBL) tools (Thornton, 1987), data analysis, and computer simulations.

Through the use of technology, the inquiry-based learning environment is made to resemble the scientific workplace. Many studies describe the benefits of inquiry-based laboratories that incorporate computing technology into a collaborative setting. Brna and Burton (1997) examined how collaboration in the model-building process using computer-based simulations has the potential for providing quality dialogues and increased comprehension of laboratory activities. At the forefront of this technology movement was Redish, who demonstrated a significant improvement in student conceptual learning when using MBL equipment instead of traditional equipment (Redish, 2000; Redish & Risley,

1990; Redish, Saul, & Steinberg, 2000). Kuntz (1998) found that a vast majority of students favor technology-infused labs over traditional ones, while Gabbard, Kaiser, and Kaunelis (2007) discuss the best style of lab table and computer system to accommodate 3-6 people with the intent of a better collaborative learning experience. Positive research findings in support of MBL activities could be interpreted in terms of the “increased opportunities for student-student interactions and peer group discussions about familiar and discrepant events in relation to ready-to-hand data” (Russell, Lucas, & McRobbie, 1999, abstract, Russell, 2004).

While Thornton was developing RTP, Sokoloff (1997) was developing his ILDs as a way to augment the lecture by way of reforming the demonstrations that are normally employed in traditional instruction. Both RTP and ILDs were designed specifically for those instructors who desire to initiate active learning in the laboratory and lecture without making extensive curriculum changes (Sokoloff, Thornton & Laws, 2004). Both PbI and WP work on the premise that it is “more important for the students to learn a few topics deeply and to build a sense of how the methods of science lead to ‘sense-making’ about the physical world than to cover a large number of topics superficially” (Redish 2003).

In addition to the traditional content within any course, teachers also convey extensive sets of attitudes and beliefs pertaining to science and the scientific process, and it is of interest to assess how these attitudes and beliefs change after instruction. This has become an area of recent concern and research (Ramsden, 1998). Student attitudes and beliefs have been correlated with both grades, learning gains, and whether students decide to continue on in physics (Adams et. al, 2004b). If teachers and researchers can better understand students’ experienced and preferred goals and roles for themselves and their teachers, then they can

better understand the effectiveness of classroom instruction (Chi, Feltovich, & Glaser, 1981, Demirci, 2000; Robinson, 1995). In the complex interactive environment of the physics laboratory, more is being learned about student epistemological beliefs, or their views about the nature of knowledge and learning, which affect how they approach physics courses (Elby, 2001b). Attitudinal research is usually qualitative, involving questionnaires, short-response essays, and interviews to get a dynamic view of students' understanding of knowing and learning in the context of the physics laboratory (Renner & et al., 1985).

Part of the goal of physics instruction is to help shift students' attitudes from "novice-like" to "expert-like." Novices in the field of science are more likely to perceive physics to be a fixed body of proven facts and absolute truths, and are thus more likely to focus on rote memorization as a way of learning. Experts, are more likely to view physics as a continuous process of concept development by which the meaning of data is interpreted, and focus more on concepts and their variations as a way of learning physics (Reid & Skryabina, 2002).

The Maryland Physics Expectations (MPEX) test was published in 1996 by Edward Redish, Jeffrey Saul, and Richard Steinberg to determine whether student epistemologies trend toward "novice" or toward "expert." The novice response is the typical response of someone who has never taken a physics course, and the expert response is drawn from a body of data acquired from physicists who are published in peer-reviewed journals and who, by definition, think about physics like a physicist.

For instance, they see physics as being based on a coherent framework of concepts which describe nature and are established by experiment. Novices see physics as being based on isolated pieces of information that are handed down by authority (e.g.

teacher) and have no connection to the real world, but must be memorized. (Adams et. al, 2004b, p. 1)

The MPEX measures the students' beliefs about the process of learning physics against the expert response, and whether that opinion improves over the length of the course. The test was originally intended as a companion analysis for the FCI, and since then, the FCI and MPEX have become the standards for measuring the success of introductory physics courses (Brewer, Kramer, & O'Brien, 2009).

The Colorado Learning Attitudes about Science Survey (CLASS) (Adams et. al, 2004a), another attitudinal survey, was developed at the University of Colorado. It built on several existing attitude surveys, including MPEX, the Views About Science Survey (VASS) (Halloun, 1997), and the Epistemological Beliefs Assessment for Physical Science (EBABS) survey (Elby, 2001), all of which attempted to distinguish the attitudes of experts from the attitudes of novices (Hammer, 1996). When used to determine whether the student beliefs about the process of learning physics change, the MPEX and the CLASS have both shown that student attitudes and beliefs almost always decline after instruction. This is mainly due to what students perceive as a disconnect between physics and reality (Redish, Saul & Steinberg, 1998). This is perhaps because students begin physics with elevated expectations due to the popularity of science-based television shows such as Myth Busters (Rees, 2003) and CSI (Zuiker, 2000), and also because students are unprepared for the amount of mathematics required.

Whatever the reasons, student attitudes and beliefs usually become more novice-like after instruction. Researchers normally see shifts of -7% to -15% in all categories as a result of traditional instruction (Redish et al., 1998). Although traditional instruction has left

students far less likely to believe that physics relates to the things they do in everyday life, inquiry-based instruction has been shown to be successful in reversing this trend (Adams et al., 2006).

Due to the success of WP, there have been numerous studies at other universities outlining the benefits of inquiry in the laboratory setting. As early as 1999, McDermott and Redish documented more than 200 inquiry-based teaching models that help guide college physicists on where to find materials for improvement of their teaching (McDermott & Redish, 1999). The following is a sampling of various reformed curriculums, intended to demonstrate the plethora of choices available for teachers and administrators.

One example is Cognitive Acceleration through Science Education (CASE), which offers an instructor's guide and a packet of 30 activities that advance a problem-solving skills enhancement by Adey et. al (1989). Another is Cooperative Problem Solving (CPS), a group-learning problem-solving environment developed by Pat and Ken Heller (Heller, Keith, & Anderson, 1992) at the University of Minnesota. Another, Minds-On Physics (Leonard, 1999), is a curriculum based on an action-oriented constructivist approach that includes student activities, a student reader, answers and instructional aids for teachers, assessment items, supplements, and answer sheets. Other available curriculums are Classroom Communication Systems (CCSs), which use technology to implement active learning in large-lecture settings; Conceptual Understanding Procedures (CUPs), which involves cooperative learning. (McKittrick, 1999); and Studio Physics, developed at Rensselaer Polytechnic Institute (Wilson 1992).

Since the study by McDermott and Redish, the development of inquiry curriculums has only accelerated. One example is the Student-Centered Activities for Large Enrollment

University Physics (SCALE-UP) project at North Carolina State University. SCALE-UP was created by Saul, Deardorff, Abbott, Allain, and Beichner (2000) to promote learning through in-class group activities in introductory physics classes of up to 100 students. It incorporates student collaboration and better classroom design, developing students who have “a better understanding of the main physics concepts, are more successful at solving problems, and are generally on-track and communicating well during group activities” (Saul et. al, abstract, 2000).

In another example, Novak, Gavrin, and Patterson (1999) collaborated with Wolfgang Christian at Davidson College to develop Just-in-Time-Teaching (JiTT). JiTT is comprised of Java-based simulations that can be used over the internet. And the list continues: The Physics Education Research Group at the University of Maryland developed Activity-Based Physics (ABP), which incorporates peer collaboration with whiteboards and small lab sets for groups of three to four students. O’Kuma et al. (2000) introduced Ranking Task exercises in Physics. Barnett and Hodson (2001) propose a model called Pedagogical Context Knowledge with which they examined the manner in which science teachers deliver science knowledge. Milner-Bolotin (2004) describes how to use a Peer-Response system in the classroom to generate instant feedback during the lesson.

Inspired by Lillian McDermott, John McBride (2004) created a similar program, also known as Physics by Inquiry, at the University of Texas - Pan American that allows pre-service physics teachers many opportunities for greater understanding in the field of inquiry and how best to apply the ideas in their classrooms. However, although the list of inquiry-based curricula is exhaustive, inquiry-based reform still faces resistance, and has yet to be adopted at many universities. The goal of this study is not to create yet another curriculum

for reform, but to put forth a research-based methodology that will encourage individual instructors to begin enacting reform at their own institutions.

### **Conceptual Framework**

This study uses Action Research to develop inquiry-based laboratory activities that are to be conducted in a highly collaborative setting. Instead of curricular development, I instead attempted to foster a philosophy of placing the student at the center of the learning process. This study is primarily about a course of action that modified my entire professional outlook. Although any particular curriculum may be advertised as being inquiry-based, it must still be presented as such by the teacher, using actions and methods that are grounded in a student-centered epistemology.

In a way, the multitude of choices listed in the previous section have made things even more difficult for teachers who are interested in beginning to teach by inquiry. Science teachers are currently faced with a daunting plethora of documents describing what and how science should be taught (Aikenhead, 1982; Cohen, 2005; Driver & Oldham, 1986; L. C. McDermott & Shaffer, 1992; Thacker et al., 1994; Viennot, Chauvet, Colin, & Rebmann, 2005). In order for reform to be accepted and promoted, innovations must be developed that seem necessary and desirable to the individual teacher (Reiff, 2002; Schneider & Krajcik, 1999; Volkmann & Zgagacz, 2004). Although there are many curricula, bundled teaching aids, and workbooks designed to facilitate reform, Schneider, Krajcik, and Blumenfeld (2005) found that materials alone are not sufficient to support learning and classroom enactment, but that reform efforts must include the personal interest and investment of the



individual teacher, as well as the support of faculty and administration. One way to generate that investment is through Action Research.

It may be that instead of trying out specific and neatly-packaged prescriptions, the proponents for inquiry should instead be encouraging others to try their own hand at inquiry solutions that make sense to them in the context of their personal teaching style and their institution's course structure and learning environment. This requires each instructor to become an Action Researcher, actively involved in the testing and development of new activities and methods.

Psychologist Kurt Lewin was credited with coining the term 'Action Research' to describe work that did not separate the investigation from the action needed to solve the problem (McFarland & Stansell, 1993, p. 14). Action Research is the marriage of theory and practice (Carr and Kemmis, 1986). It is important that educators conduct Action Research and write about their experiences and findings in order to add to the PER community consensus knowledge base. Individual professors and laboratory instructors often develop deep insights into how their students learn and what elements of classroom instruction are valuable in facilitating the learning process. If published in the form of reflective Action Research, these insights can persist beyond the individual instructor, and cumulate increasingly powerful knowledge in the way scientists expect understanding to grow (Redish, 2000).

In order to accumulate, evaluate, and refine what we learn, instructors must work together to build an over-arching theoretical framework that is strongly rooted in real-life observations. Redish (2004) gives examples of how theoretical orientation can affect instruction and research, and suggests that building a community of research will allow us to both make sense of what we see in the classroom and to compare a variety of specific

theoretical approaches. A study by educational researcher Allan Feldman (1994) that examined ways in which we use our own experiences as well as those of our colleagues to become better teachers determined that Action Research needs to be self-sustaining in order to have a long-lasting effect on practice. In other words, the cycle of learning that is characteristic of Action Research, must continue to be repeated in order to refine instructional techniques.

After testing any particular activity, the instructor reflects on the effectiveness and pertinence of the results based on personal observation, student and instructor feedback, and student performance on conceptual post-lab questions. Then it is “back to the drawing board” to enact modifications that make sense based on the unique context of educational climate, equipment funding, and laboratory space. After the proposed changes have been made, the cycle continues (Kemmis and McTaggart, 1988). This type of Action Research restores the power of decision making back to the individual teacher, and does not allow for a fixed, prescriptive curriculum. Effectually, it offers each instructor or laboratory director the opportunity to learn inquiry *by* inquiry. This type of instruction is both personalized and contextualized because of the personal investment of the researcher.

Action Research not only adds to existing knowledge, but also develops understanding and serves as a method of faculty development. For example, the Action Research of this project was the study of my own actions and the effect of those actions within the context of the physics laboratory. It was also responsive to the emergent needs of my research design. Since Action Research is cyclic in nature, a weekly pattern of **plan → act → observe → reflect** (see Figure 1) soon emerged.

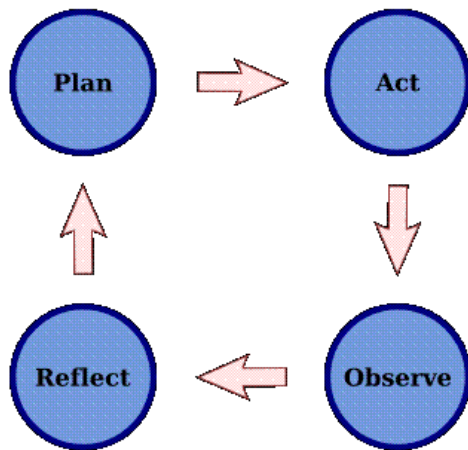

Figure 1. The four stages of Cyclical Action Research (Kemmis and McTaggart, 1988).

Another vital aspect of inquiry-based reform is the importance given to group discussion and argumentation in the scientific process. In a physics-by-inquiry laboratory, student/student interactions are maximized, while student/teacher interactions consist of limited guidance and Socratic dialogue. The laboratory experience can be made more beneficial by encouraging discussion between students (Watson, Swain & McRobbie, 2004). Open-minded groups that are willing to listen to each person's opinion are more successful in the learning environment than those groups who are less willing to consider others' ideas (Alexopolou & Driver, 1996). According to the National Science Education Standards (NSES) set out by the National Research Council (1996), science is a collaborative endeavor, and all science depends on the ultimate sharing and debating of ideas. Interactions among individuals and groups in the classroom are vital (Reid & Skryabina, 2002). At all stages of inquiry, teachers guide, focus, challenge, and encourage student learning. All this helps students to formulate questions and devise ways to answer them, to collect, organize and represent data, and to test the reliability of the knowledge they have generated (Arons, 1993).

Using action research, I set out to develop technology-based, hands-on activities designed to take place in a collaborative physics laboratory. These activities facilitated small group learning conversations, allowing students to articulate and justify their own science conceptions, critically reflect on their partners' views, and negotiate new, shared meanings (Kearney, 2004). Compared to students taught in traditional classes, students who learn in a collaborative environment are better problem solvers, achieve nearly four times the gain on conceptual tests, have better attitudes toward science, and report greater satisfaction with their instruction (Beichner, Saul, Allain, Deardorff, & Abbott, 2000). Syh-Jong (2007) examined students' construction of science knowledge through talking and writing activities performed in a collaborative learning group. He found that writing and speaking in a collaborative group required students either to defend their own view or accept others' views whenever confronting science concept understandings, not only were students stimulated to make their understanding of the concept explicit through the reciprocal use of oral and written language, but they also derived other students' ideas as explanations in verifying, clarifying, elaborating or modifying or altering their own understanding. (p. 14)

Roth (1994) called for the development of constructivist learning environments in which students could pursue open inquiry and frame their own research problems, providing students with "problem-rich learning environments in which they learn to investigate phenomena of their own interest and in which they can develop complex problem-solving skills" (p. 197). Marshall (1997; 2000) found that the use of collaborative inquiry activities as a supplement to traditional lecture and demonstration curriculum significantly improved student achievement.

Collaboration within the laboratory gives focus to social practice, meaning, and patterns, permitting students to construct knowledge meaningfully in an appropriate social context. Crouch, Watkins, Fagen, and Mazur (2007) reported on data from more than ten years of teaching with *Peer Instruction* (PI) in introductory physics at Harvard University. PI is an “instructional strategy for engaging students during class through a structured questioning process that involves every student” (abstract). Harvard’s results indicate increased student mastery of both conceptual reasoning and quantitative problem solving upon the implementation of PI. The benefits of collaboration are confirmed by Qin and Johnson (1995), who showed that members of cooperative teams outperformed individuals competing with each other on four types of problem solving.

Because the students learn in groups of peers, the inquiry-based learning environment bears “more resemblance to the scientific workplace than to the usual traditional teaching environment” (Thornton & Sokoloff, 1990, p. 866). This is because the role of the teacher is different in an inquiry class than in the traditional classroom. The goal of the teacher is to help create the learning environment, lead discussions, and encourage students to engage in reflective discourse with one another. The teacher does not give a packaged solution, but guides the team through problems by means of “references to the text, Socratic dialogue and disequilibrium” (Sharma, 1999, p. 843).

Bergquist (1991) also conceived of the physics lab as a set of inquiry questions that served to introduce students to natural phenomena even before it is presented to them using physics vocabulary and equations during the lecture. Uretsky (1993) claimed that the conventional lab report was a pedagogical rite long overdue for oblivion, and championed the use of “dialogue” labs to bring about student confrontations with physics concepts.

Using this conceptual framework of Action Research, collaborative, dialogue-based laboratory activities were developed and enacted each week. After each laboratory session, instructor notes and videotape were analyzed and reflected upon, an action that informed the next week's planning session. In this way, experimental designs were employed in the latter weeks of data collection that capitalized on the information gained during the earlier weeks. This conceptual framework informed the methodology, which will be discussed in Chapter III.

## CHAPTER III: METHODOLOGY

### **Methodological Approach**

The methodological approach employed in order to correctly apply and assess the effectiveness of inquiry-based laboratory reform is described in this chapter. The discussion begins with a definition and a justification for Action Research. Action Research is a practical, reflective methodology often used in PER (MacIsaac, 1996), and is appropriate for this study because it lends itself so well to practitioners who wish to improve their own educational program and who would like to formulate a plan, carry out an intervention, observe the effects, evaluate the outcomes and develop further strategies in an iterative fashion (Hopkins, 1985). Educators work best on problems they have identified themselves and in contexts that they are familiar with (Ferrance, 2000). One of the goals of this study is to develop a method that encourages the implementation of inquiry-based laboratory reform by transforming the educator into a researcher, for which an Action Research methodology is an obvious choice.

In addition to offering a rationale for the use of Action Research, this chapter will describe the design of the study. Laboratory goals and outcomes were developed, from which came grading rubrics and the inquiry-based “QuickGuides.” The academic setting, the participants, and the selection process are described, along with the assessment tools and the

method of coding and analyzing the data. In addition, ethical issues and the trustworthiness of the study are discussed.

### **Research Question**

*Is it possible to enact effective, inquiry-based reform research in a post-secondary, undergraduate physics laboratory without a major restructuring of class size, meeting pattern, and content coverage?*

### **Research Design**

The first step to enacting effective change was to clearly outline the goals and objectives of the laboratory, and then to develop a clear method of assessing whether those were being accomplished. Before the semester began, I sat down with the other members of Appalachian's PER group (Drs. Allen and Saken) to brainstorm what we would most want students to learn from their lab experience at Appalachian. Below is the list of desired learning outcomes that was developed.

By the end of each semester, each student will:

1. Exhibit scientific investigative skills as shown by:
  - a. Setting up lab equipment safely and efficiently
  - b. Planning and carrying out experimental procedures for situations under investigation based on generating a hypothesis, predicting outcomes, and developing alternative models, as needed
  - c. Identifying appropriate sources of error and explaining the impact of these errors



- d. Implementing measurement techniques and equipment that enhance precision
  - e. Acquiring and interpreting data
2. Construct and evaluate graphs to model, infer, and predict real-world functions.
  3. Demonstrate communication skills by using appropriate scientific language and available technology to report, display, and defend experimental results.
  4. Display professional behavior in the lab by:
    - a. Demonstrating responsibility for her/his own learning by seeking help from instructors and other students
    - b. Functioning as a productive member of a group cooperating in lab learning tasks

In addition to matching the goals of our PER group, these learning outcomes were specifically worded to align with the goals of the American Association of Physics Teachers (AAPT), and also the General Education Taskforce at Appalachian State University (GET, 2007), which explicitly recommends the use of scientific inquiry:

Themes designed to teach the process of science should require students to:

1. Gain knowledge about the physical world and an understanding of the scientific method;
2. Investigate questions through inquiry-based pedagogy that involves experimentation and inferential analysis;
3. Interpret scientific information where a synthesis of ideas is achieved;
4. Use quantitative and mathematical concepts, especially data presented in graphical or tabular form, to interpret results;

5. Discuss scientific findings and examine the nature of contemporary scientific debates.

The NSES also mandates that achievement data collected focus on the science content that is most important for students to learn, and that opportunity-to-learn data collected focus on the most powerful indicators. These indicators are:

1. The ability to inquire.
2. Knowing and understanding scientific facts, concepts, principles, laws, and theories.
3. The ability to reason scientifically.
4. The ability to use science to make personal decisions and to take positions on societal issues.
5. The ability to communicate effectively about science.

(National Research Council, 1996)

With these goals and outcomes in mind, grading rubrics were developed (refer to Appendix A). A report grading rubric was created to assess the quality of the submitted laboratory report. Each element assessed by the laboratory report rubric was scored on a scale from 0 to 3, with 0 being unacceptable, 1 being acceptable, 2 being good, and 3 being excellent. For each element, students were given specific examples of the types of responses that would result in scores of 3, 2, 1, or 0. Each element of the report was weighted anywhere between 5 and 15 points, which fluctuated depending on the requirements of each report. For example, if a report was more graphical in nature, then the graphing element would carry a heavier weight. The next week, calculations or data might take a higher priority. In this way,

the rubric was a fluid document that was able to more accurately address the most important sections of each laboratory.

In order to assess the more intangible of the desired goals and outcomes of the physics labs, it was decided that there should also be an observational rubric (Appendix A). There were four categories listed in the rubric. The first category was time management, which assessed whether students came to lab prepared and stayed on task. The second category was used to determine how well students demonstrated experimental design and process skills. The third category made it possible to comment on students' respect for others and for equipment, while the fourth and final category evaluated the students' capacity to communicate with their partners, the instructor/lab assistants, and the class as a whole. There were two columns labeled "observed positive" and "observed negative," and a "comments" column in which the instructor or assistant could make clarifying remarks or record various issues that arose during each lab meeting.

At the beginning of each laboratory session, the instructor and all assistants were given a copy of this rubric, which they carried around with them as they moved about the room. Using the categories in the scoring grid, they wrote down the names or initials of the individuals who stood out (for good or bad). Each person involved in lab instruction filled out their own form so that a more complete assessment could be made by combining the names and comments of the various instructors and assistants. For each lab meeting, the lab instructor determined the average performance for the class, which was normally around 85%, or a 'B.' This grade was given to the students who achieved the goals of the laboratory within the allotted time. Students who were noticeably doing additional things or standing out in a positive way received a higher score than the "average" student. This way, students

who went the extra distance to complete a task, asked appropriate questions, or who were group leaders each week received higher weekly scores. Likewise, students who were disruptive, were unprepared or watched others do all the work received lower scores.

Another of the goals of the inquiry-based reformation was to minimize the time that the instructor spent lecturing at the beginning of lab. In order for students to learn how to use the equipment without spending precious hands-on time listening to an instructor talking about it, a series of guides was developed that would help the students learn how to connect the sensors to the computer and acquire data. These were called “QuickGuides,” and each QuickGuide contained short activities that were designed to familiarize students with a particular probe or sensor.

This idea of developing QuickGuides to probes and sensors soon expanded to include QuickGuides for concepts. These guides were also short in length, and made use of the technical knowledge gained while performing the equipment QuickGuides. They were designed to be open-ended, with “play-time” built in to each lesson. This play-time occurred at the beginning of the lab period, when students performed non-guided tests and measurements with select equipment or software in order to gain a working knowledge of how to operate and manipulate the apparatus. Play-time was also incorporated near the end of the lab period, when students had mastered the use of the apparatus and could perform non-guided experiments of their own design.

Soon, an extensive library of QuickGuides was compiled, though none were long enough to serve as stand-alone labs. This was different than the traditional labs, which were designed to last one lab period, with a definite starting and stopping point. The QuickGuides are more like real-life research, in which one discovery may lead to another, taking the

researcher down paths unforeseen at the outset of the experiment. The traditional idea that every lab must consist of a neatly packaged experiment creates an environment in which students are on a mission to complete the assignment and then leave. Rather than experimenting, students would hurriedly work through the instructions, trying to collect just enough information to complete the assignment and leave, with no inquiry-based or self-discovery exploration whatsoever.

In the traditional laboratory, timing is critical. If the activity is too short, then students are exiting the lab before learning requisite skills and concepts. If the activity is too long, then the students are unable to complete all the steps during the allotted time. It is, therefore, a challenge for the designer of traditional labs to create a lab that spans the entire lab period. With QuickGuides, however, most activities ranged from twenty to thirty minutes, and there were always several activities to perform that reinforced the same concept. These QuickGuides were grouped into major topical units, with each unit spanning two to three lab periods. Therefore, there was never a fear of running out of activities or of running over the allotted time.

Activities that took place early in the unit were more qualitative and conceptual, with students spending the entire period in constant hands-on activity. As the unit progressed, the activities became more quantitative. The final activity of the unit was designed to be conducive to a written laboratory report, replete with graphs, calculations, and detailed analysis. The schedule for the labs was such that the traditional and experimental laboratories covered basically the same topics at the same time, which were aligned with the order of lecture instruction.

## **Design Rationale**

During the two semesters of my dissertation research and afterward, I employed an Action Research methodology. Undertaken in a school setting, it is a “reflective process that allows for inquiry and discussion as components of the research” (Ferrance, 2000, p.1). Action Research is distinct from other types of research in that it specifically refers to a disciplined inquiry done with the intent that the research will inform and change his or her practices in the future. This research is carried out within the context of the teacher’s environment—that is, with the students and at the school in which the teacher works—on questions that deal with educational matters important to that teacher (Goodsen, 1993).

In this case, Action Research informed every aspect of the study (refer to Figure 2). Each week, QuickGuides were developed and alterations were made informed by the reflective processes required by Action Research. Sometimes changes were made on a daily basis. For example, the original QuickGuide for torque had mistakenly included an equation for the rotational equilibrium of a meter stick. Between labs, I removed the equation and found that the students of the next experimental section developed the equation independently and attained a better understanding of torque. Even after the completion of this study, this Action Research will continue, expanding to ever widening cycles that regenerate semester-to-semester rather than day-to-day and week-to-week.

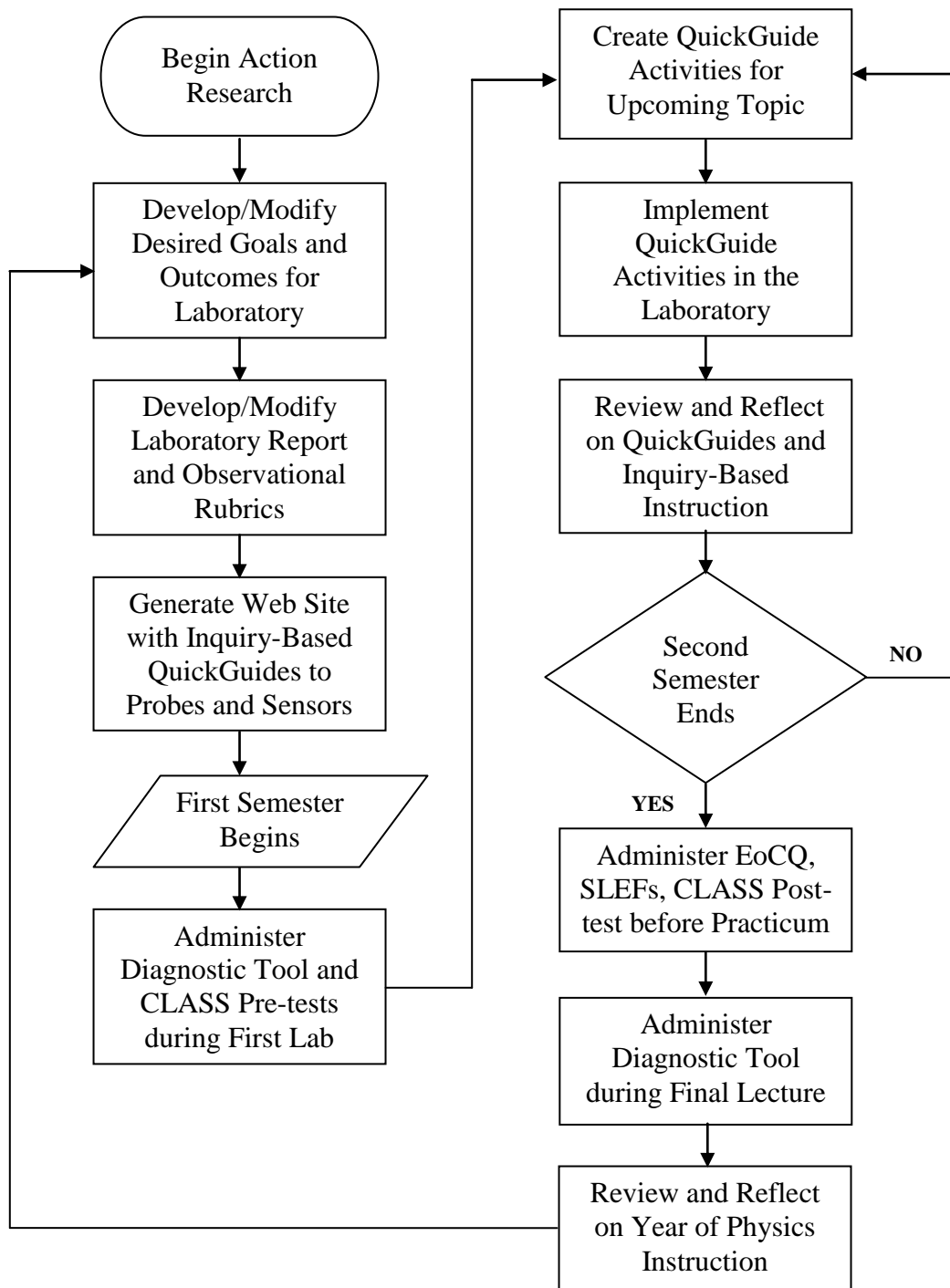

Figure 2. Flow of Action Research in this Study.

Action Research can also be a form of teacher professional development, giving teachers opportunities for research and reflection, and for continuously determining ways to improve (Kelsay, 1991). Using Action Research, I was able to implement inquiry-based laboratory reform in my own university setting and at my own pace, and in a way that can be construed as legitimate educational research and presented to the PER community.

Teacher interest and investment are paramount to any curriculum, and inquiry-based instruction is no different. In order for inquiry to take a foothold, it must capture the attention of individual instructors. In this study, I brought into question the legitimacy of my own teaching methods, using Action Research as a method of validation. According to science education researcher Stephen Corey, one of the founding fathers of Action Research, the disposition to study “the consequences of our own teaching is more likely to change and improve our practices than is reading about what someone else has discovered of his teaching” (Corey, 1953, p. 70).

### **Role of the Researcher**

It is important for researchers to make known who they are in the context of the study, making explicit what draws them to ask the question around which the study is centered. In the introduction, I related how I gained interest in inquiry-based physics, why I decided to implement this kind of reform at Appalachian, and also my desire to make my methods and findings available to other teachers/researchers who also want to try this type of study. As Director of Laboratories in Physics and Astronomy, I am in a unique position to make curricular and methodological changes that would reflect recent advances in PER. In



this capacity I am an active member of the Department of Physics and Astronomy at Appalachian, and my actions and the research that I undertake directly influence the educational atmosphere. In this role, I am also a supervisor, and I can use this role to delegate tasks relating to inquiry-based research, and to train others in how to plan and carry out Action Research.

As a doctoral student in Educational Leadership, I had recently become familiar with the social implications of educational research under the tutelage of my instructors in the Reich College of Education (RCOE). The conceptual framework of the RCOE is established upon underlying principles (Reich College of Education, 2010) that are based on social constructivism. As I moved into a leadership role in my own professional career, it was natural for me to adopt these same principles into my own practice. Within the context of my role as a learner, I was a member of a “cohort” of students who formed a Community of Practice based on our common goal to learn and graduate. This continues to define my role as researcher as I transition from a Community of Practice consisting of a small group of students, to one of hundreds of professional researchers in the PER community.

My professional community of practice (an interconnected community of individuals who have common goals and values) is the field of physics educational research and so I joined a local PER group within our department that included Dr. Patricia Allen and Dr. Jon Saken. We meet weekly to discuss recent findings in PER and to reflect on how this would affect our own methods of instruction. As a member of the PER community, my role is to learn from what others have discovered, put these findings into practice, and then to disseminate the results of my research so that other members may learn from me. To this end I have presented posters at the annual meetings of the American Association of Physics

Teachers, and co-authored a paper published in the Physics Educational Research conference proceedings (Allen and Cockman, 2009). These actions are having the result of encouraging other practitioners to enact their own form of Action Research, and giving them some of the tools to do so.

One of my roles as researcher is to facilitate a social context that maximized positive student/student and student/teacher interactions, setting up a community of practice within the physics laboratory. These interactions are key to inquiry-based instruction, in which students are asked to work together to come up with a plan of action, predict outcomes, and present findings. Another part of my role as Action Researcher is to determine the effectiveness of my applied research in helping students transition from novice to expert. As the instructor responsible for applying the plan for inquiry-based reform, it is my responsibility to serve as an expert, helping students to acquire the requisite knowledge, skills, and attitudes that will enable them to become not only more expert at physics, but also more expert members of their own scientific communities of practice. This aspect of my research was evaluated using the Colorado Learning Attitudes about Science Survey (CLASS) to measure changes in student attitudes in terms of a movement from novice to expert following a semester of instruction. It is also my own role as a learner to bring my attitudes and values into alignment with my teachers, my dissertation committee members, and the other experts in my Community of Practice already conducting meaningful physics educational research.

### **Ethical Issues**

At the outset of this research, all measures were taken to conform to the standards set

forth by the Institutional Review Board (IRB). The IRB is a university committee that protects the rights and welfare of human subjects who are participants in research conducted by Appalachian State University faculty, staff, or students. It was established by a federal mandate, and carefully reviews research involving human subjects according to the policies of the United States Department of Health and Human Services. Online training was given to all involved with the administration of the research, and IRB approval was granted for my research project. At the beginning of the Fall 2009 semester, I obtained informed consent that was signed by all participants. All students were informed that they had been selected as participants in a study that would evaluate the effectiveness of the physics labs. Students were promised a high level of confidentiality, and risk of harm to students was determined to be minimal. No student declined participation in the study.

In this study, I was the researcher who, as required by Action Research, both facilitated and analyzed the research procedure under study. Thus, ethical issues of researcher role should be addressed. According to Michael Patton, former president of the American Evaluation Association, “the researcher’s personal experiences and insights are an important part of the inquiry and critical to understanding the phenomenon” (2002, p. 40). The researcher must recognize that he or she has a unique vantage point that might cause events to be interpreted differently than others with different backgrounds, roles, and experiences (Derry, Hickey, & Koschmann, 2007).

As such, the researcher must make every effort to be upfront and honest about biases and prior assumptions that may affect outcomes. Entering the study, I was naturally sympathetic toward the inquiry-based physics reform as a result from my readings of PER. I did not perceive this as overtly subjective, but I did recognize it as a bias. However, data and

results were presented honestly, with conclusions based on the merits of the study alone, and not on my a priori assumptions or my professional prejudices. I hoped that by recognizing my subjectivity at the beginning of the study, I would be able to make intellectual allowances for those feelings. In addition to the perspective of the researcher being stated and understood, prevention of researcher influence must be addressed. Patton (2002) gives several different ways in which a researcher might unduly influence the data of a qualitative inquiry. Among these are Researcher Presence, and Value Imposition, neither of which were eliminable due to the nature of my research.

According to Patton, participants of a research study sometimes react differently in the presence of the researcher thus unduly influencing the data generated. One way to minimize this kind of influence is for researchers to allow for an appropriate period of time for themselves and participants to “get used to each other” (p.473) before data is collected. This is similar to the findings of other studies that have shown that teacher interest in a test can cause students to take more interest in the subject and, therefore, skew results (Christophel and Gorham, 1995). However, in this study, data was collected from the very first interaction.

The effect of Researcher Presence may have been most strongly observed in the application of the CLASS pre-test. Unlike the Diagnostic Tool, the CLASS did not test direct knowledge of physics of concepts. Instead, the CLASS tests attitudes and beliefs about physics and compares them to those held by experts. In this way, the CLASS is much more susceptible to researcher influence. Before being administered the CLASS, the students had already signed the Informed Consent letter required by Appalachian’s Internal Review Board (IRB), which had alerted them to the fact that they were part of an instructor-conducted

research project. It is plausible that my enthusiasm for the project may have been the cause of a temporary increase in interest and optimism. The other lab sections, however, were administered by graduate students who were not researchers, and in fact had little interest in or knowledge of my research, and so did not confer to the students the same level of enthusiasm. Because each laboratory section contained roughly the same mixture of students, there should have been no significant difference between pre-test scores on the Diagnostic Tool or the CLASS on the first day of lab. If the three sections that I taught responded significantly higher than the other sections taught by graduate students on many portions of the CLASS pre-test, while showing no significant difference on the Diagnostic Tool, this would raise a flag to the effect of Researcher Presence.

Value Imposition is described by Patton as a way that a researcher can influence the results of a study. Value Imposition occurs when a researcher unknowingly imposes his own values, beliefs, or biases onto the participants and thus unduly influences the data. However, because this study sought specifically to modify the attitudes and behaviors of students in order to create an inquisitive, collaborative environment, a certain amount of value imposition was absolutely necessary. A certain amount of student “buy in” is required in order for inquiry-based reform to be effective (Laws, 1997). Direct value intervention is also offered as a way to attain positive gains on an attitudinal survey such as the CLASS (Adams et. al, 2004b). Researcher influence is therefore not a fatal research defect, but rather an unavoidable artifact of meaningful Action Research (Denzin, 1998).

Another unavoidable property of Action Research is that it is performed in one’s own “backyard” (Glesne & Peshkin, 1992). Backyard research is research performed in one’s own institution using participants selected based on convenience instead of on sound

methodological strategies. In this study, participants were chosen based on a self-selecting registration process. There was no prior knowledge of any particular student, and no reason other than convenience and possible scheduling conflicts for students to enroll in any particular section, so the selection process, although not random, was not compromised by researcher bias.

Issues of prolonged engagement, insider status, and personal experiences in one's own natural setting pose an additional burden and a potential conflict for the researcher (Lincoln & Guba, 1985). While there are benefits to having an intimate knowledge of the educational context through personal experience, there also exists the challenge to view a familiar setting through the eyes of an external observer (Coffey, 1999). This was addressed by including the observations and reflections of a graduate assistant who was not a teacher, nor an expert in inquiry-based physics. My conversations with this assistant following laboratory sessions were useful because they gave fresh insights into the interactions from the perspective of an outsider.

As a benefit of performing backyard research, my personal and professional interest had given me a well-grounded knowledge base entering into the study, and a high motivation for completing it and drawing meaningful conclusions. Research, done with the teacher's students in a setting with which the teacher is familiar, helps to confer relevance and validity to a disciplined study. Often, academic research is seen as disconnected from the daily lives of educators. While this might not always be true, it can be very helpful for teachers to pick up threads suggested in academic circles, and weave them in to their own classroom. In that way, the teacher is not just blindly following what the latest study seems to suggest, but is transforming the knowledge into something meaningful.

Lastly, Patton lists Professional Incompetence as a way that an untrained or inexperienced researcher may exert undue influence on a study. Because I played dual roles of facilitator and researcher in this study, it is appropriate to question whether I had the requisite knowledge and experience in this field to avoid the pitfalls of Professional Incompetence. As mentioned in the introduction, this was my first foray into personally teaching inquiry-based physics. However, in the two years previous to this study, I had studied the relevant literature exhaustively and had obtained a respectable knowledge in this area. I assisted in a summer Modeling-based Physics workshop at Appalachian State, and had attend a week-long Activity-Based Physics Faculty Institute in Carlisle, PA that was conducted by leaders in the field of inquiry-based physics reform. I also received a grant from Appalachian's General Education Taskforce, which had allowed me to purchase new equipment and rewrite the conceptual-based physics labs over the summer. Through all of this, I was given continuous guidance during the planning and preparation stages, as well as during the actual study, by the more experienced members of my PER group. As a result, I felt very confident facilitating this research process in a professional manner.

### **Trustworthiness**

The Diagnostic Tool used at Appalachian State is a 34 question conceptual exam that is based on the FCI. Both the FCI and the CLASS are validated instruments (Adams et. al, 2004a). The FCI has been administered to thousands of physics students since its inception, and has been shown to be reliable. Face and content validity has been established through the support of the numerous physics instructors who have used it. The CLASS has been

validated using interviews, reliability studies, and extensive statistical analyses of responses from over 5000 students (Adams et al., 2006).

There have been challenges and criticisms of the FCI. Some criticisms attack the rationale behind the groupings of questions (Huffman and Heller, 1995), the choice of 60% as an indication of a mastery of mechanics (Mahajan, 1995), and the reliability of the study after some questions were changed after 1995 (Dancy, 2000). However, these critics concede that the FCI is one of the most reliable and useful physics tests available for introductory physics teachers, and it continues to be the most commonly accepted test of student conceptions. This is probably due to the large amount of data available with which to compare the test results, making the FCI “unique in its ubiquity” (Royuk, 2002, p. 17), especially with respect to the study of mechanics.

The FCI was originally considered as a set of tools to assess the success of this study. However, because of the historical departmental data already amassed using the FCI-based Diagnostic Tool, it made more sense to continue using the Diagnostic Tool. Although not as well-validated as the some other tests used in PER, the Diagnostic Tool has been used exclusively by the department for the past five years in order to improve curriculum and to provide meaningful feedback on the effectiveness of instruction. Because many of the questions are taken from the FCI itself, this subset of questions can be qualitatively compared with results from other institutions.

Although the instruments may be valid, one indication of trustworthiness in a qualitative inquiry is that the inquiry’s findings are based on a sound interpretation of the available evidence (Lincoln & Guba, 1985). In order to establish the trustworthiness of any research, credibility, transferability, dependability, and confirmability need to be established.



Credibility is an evaluation of whether or not the research findings represent a “credible” conceptual interpretation of the data drawn from the participants’ original data (Lincoln & Guba, 1985, p.296). One way to increase credibility is by a method of data triangulation. Triangulation is “a validity procedure where researchers search for convergence among multiple and different sources of information to form themes or categories in a study” (Creswell & Miller, 2000, p. 126). In this study, the two primary sources of data were the Diagnostic Tool and the CLASS.

Other data sources were used to gather more information specific to the laboratory and to increase credibility by data triangulation that supported the analysis of the CLASS results. These were an end-of-course Likert-type survey and the Student Laboratory Evaluation Forms (SLEFs). Additional insight and corroboration was gained through an analysis of lecture grades and a video analysis of student/student and student/teacher interactions. Another element that increased the credibility of this study was the presence of experienced peers, members of my PER group who provided constant feedback and assistance as I went through the process of planning, acting, observing, and reflecting.

Transferability is the degree to which the findings can apply or transfer beyond the bounds of the project. This is one of the strengths built into this study, which was created with transferability of methodology in mind. One of the complaints with inquiry-based curriculums is that they have such a low transfer rate, but that is referring to a transfer of curriculum. Instead of offering a prescribed curriculum, this study presents a methodology designed for maximum flexibility. Action Research as a framework for curricular improvement can be performed by any practitioner, and the QuickGuides offer an example of simple and effective activities, grouped into topical units, that can be used as a template to

inject inquiry into almost any laboratory setting. One way to increase the transferability of the study is to provide easy access to the “paper trail” that will give other researchers the ability to repeat, as closely as possible the procedures of this project, or to transfer the conclusions of the study to other cases. Appendixes G and H include the QuickGuides that were developed and also descriptive field notes that portray an accurate portrait of laboratory climate and activity.

Inter-reliability was tested by requiring a graduate assistant to keep a weekly journal of laboratory experiences, then comparing with the researcher’s journal for omissions and inconsistencies. The research was open, auditable, and reproducible to a certain extent. Although my observations were unique in my role of teacher/researcher, it was possible for an outside observer to retrace the genesis of any particular interpretation.

Dependability is an assessment of the quality of the integrated processes of data collection, data analysis, and theory generation. Confirmability is a measure of how well the inquiry’s findings are supported by the data collected (Lincoln & Guba, 1985). Dependability is increased if results are consistent over time. Two semesters were spent observing and teaching laboratories, gathering feedback from research advisors, and interacting with faculty and student participants. Also, both the Diagnostic Tool and the SLEFs were easily compared to readily available historical data. In order to confer verification and insight, interpretations and conclusions were discussed with the participants, the assistants, and with peers, providing feedback from differently-biased sources. The members of my PER group audited both the dependability and confirmability of the project, as well as the completeness and availability of auditable documents. The findings had external validity in that they could be easily generalized to the population of physics laboratory instruction as a whole. These

findings were not necessarily dependent on context, and would likely hold up in other settings or situations. Conclusions were consistent with the main body of PER research concerning inquiry-based physics.

### **Participant Selection**

The Department of Physics and Astronomy at Appalachian State offers three different levels of introductory physics in order to serve the particular needs of the university. There is a conceptual course, which is populated by students who have no need to take higher math and are just meeting their general science requirement, or who are interested in learning about physics while employing minimal mathematics. These labs were not chosen for this study because the course is already undergoing inquiry-based reform aided by a grant from the General Education Task Force at Appalachian.

There is also a calculus-based course, which is offered for physics, pre-engineering, and computer science majors, or any other science major who is considering graduate school and wants to cultivate a more rigorous transcript. Along with the calculus co-requisite, this course also requires a greater knowledge of trigonometry and algebra than does our algebra-based course. Because this is the course from which we draw the majority of our majors, there is some departmental resistance to performing any untested experimentation on the associated laboratories at this time.

The participants of this study were taken entirely from the algebra-based physics laboratory. The algebra-based course, or trigonometry-based course as it is sometimes called, is a blend of the conceptual and the analytical that requires students to have basic knowledge of trigonometric functions such as sine, cosine, and tangent, and also requires a proficiency

in manipulating and interpreting algebraic equations. It is populated predominately by majors of other sciences such as biology, chemistry, exercise science, etc. Historically, these sections have posted low scores on the Diagnostic Tool, indicating a need for some type of intervention. If successful, this intervention could then be adjusted in order to serve the calculus-based or conceptual-based sections.

The students in the algebra-based sequence were distributed into three lecture sections. Of these three lectures, two were taught in a traditional lecture style, while the third, taught by Dr. Allen, employed a modeling-based methodology. These sections met for one hour, three times weekly. Enrollment in these courses was based on availability and student preference. Students also enrolled in six laboratory sections of a maximum thirty-two students each. The labs met once a week for two hours (see Table 1). Two labs took place daily on Tuesday, Wednesday, and Thursday of each week. Because no specific instructor was listed for these laboratories, students enrolled based on availability and convenience.

I taught the first three laboratory sections (two experimental and one traditional) of the week, with the help of a graduate assistant. The last three traditional laboratory sections of the week were co-taught by two other graduate students who had both taught the same traditional laboratories the year before. The Tuesday sections were selected to be experimental sections. This left time on Wednesday mornings for student employees to make any equipment changes for the four traditional sections who met on Wednesday and Thursday afternoons.

For the purpose of interpreting the results, students were divided into two lecture categories and two laboratory categories, and then overlaps between categories were analyzed. The two lecture categories consisted of the modeling-based lecture and the two

traditional lectures. The two laboratory categories consisted of the Tuesday experimental sections (58 students) and the Wednesday and Thursday traditional sections (118 students).

Table 1.

Algebra-based laboratory and lecture teaching schedules

	MON	TUE	WED	THU	FRI
11:00	Modeling-based lecture		Modeling-based lecture		Modeling-based lecture
12:00					
1:00	Traditional lecture		Traditional lecture		Traditional lecture
2:00					
3:00	Traditional lecture		Traditional lecture	Traditional lecture	
4:00		Experimental laboratory <b>(Researcher)</b>	Traditional laboratory <b>(Researcher)</b>	Traditional laboratory	
5:00					
6:00		Experimental laboratory <b>(Researcher)</b>	Traditional laboratory	Traditional laboratory	
7:00					

Since algebra-based introductory physics is a two-semester course, some amount of student movement and attrition between semesters was inevitable. Because of this, some students received only one semester of the experimental labs. However, the large majority of students retained their schedule format from the previous semester, and therefore remained in the same laboratory sections. Students who changed sections between semesters had the

inconvenience of learning a new style of instruction very quickly at the beginning of the semester, and also had to adjust to an entirely different grading scale. Also, it was determined after analysis that grades and diagnostic scores were not significantly different for students who were enrolled in one rather than two semesters of inquiry-based instruction. To avoid analyzing a new category of students that had very small numbers, any student who had taken at least one semester of experimental physics labs was considered to be part of the experimental laboratory group.

### **Data Sources and Collection**

In order to assess the success of the applied research, the PER community has long relied on the pre- and post-tests that assess gains in student knowledge of basic concepts, and also student attitudes and beliefs about science. To assess conceptual gains, the Physics Department at Appalachian State developed a Diagnostic Tool (see Appendix B) that has been in effect for multiple years. I decided that this study would take advantage of this tool and the wealth of historical data with which to compare the experimental results.

The Diagnostic Tool is a matched pre/post-test administered at the end of the second semester of experimental laboratory instruction, but does not factor into the student's grade. It consists of 34 conceptual questions pertaining to a conceptual understanding of other topics covered throughout the two-semester course. Nearly two-thirds of the questions are taken from the Force Concept Inventory (FCI) (Hestenes, Wells, & Swackhammer, 1992), which is widely used in physics educational research. The authors of the FCI claim that low scores are indicative of a poor understanding of the force concept, and that the threshold scores of 60% and 85% indicate an entry level and a mastery level of understanding,

respectively. Historically, the scores of Appalachian's algebra-based sections are very low, lagging well behind those of the students in the calculus-based sections. The average algebra-based pre-test FCI score is 29% while the post-test average is 39%, well below the scores Hake determined for traditional instruction and also below national values for traditional instruction (Hake 1992). Additionally, none of the item responses have been above Hake's Newtonian entry threshold of 60%. Unfortunately, one of the traditional lecture sections did not participate in the post-test due to time constraints, and thus only the Modeling-based section and one traditional section were available for comparison.

Because the Diagnostic Tool tested gains in student knowledge of concepts, there is historically a correlation between Department Diagnostic scores and course grades. If gains in the laboratory affected scores on the Diagnostic Tool, course grades should also be affected, indicating a "transferability of conceptual-based and performance-based skills from the laboratory into the classroom" (Allen and Cockman, 2009, p.74). Therefore, lecture grades were analyzed to determine whether changes in the lab would have an effect on overall performance. Student performance in various graded components of all sections were analyzed, including averages for class work, exams, the final exam, laboratory, and overall course grade.

The CLASS (see Appendix C) consisted of 42 statements that students responded to using a five-point Likert-type (Likert, 1932) scale (strongly agree to strongly disagree). Each response was then categorized as "favorable," "neutral," or "unfavorable" based on its level of agreement with the "expert" response. The expert responses were gathered from physicists who were published in peer-reviewed journals and who, by definition, think about physics like a physicist. These responses established a pattern of envisioning physics as a coherent

framework of concepts that describe the way the universe works and that are established and verified by an experimental process. Novices, on the other hand, often see physics as isolated pieces of information that are disseminated by authoritative sources such as teachers or the government, having little connection to the real world, and which must be memorized rather than understood.

A student's "Overall percent favorable" score indicated the percentage of responses that agreed with the expert response. Similarly, the "Overall percent unfavorable" score indicated the percentage of responses that disagreed with the expert response. These individual scores were averaged to determine the "Overall percent favorable" and "Overall percent unfavorable" score for all participating students. Line-by-line responses to the pre- and post-tests were entered into a spreadsheet that was developed at the University of Colorado for the purpose of thematically grouping questions. The survey was thus broken down into seven major subsets of statements (see Appendix D) that measured specific attitudinal categories in terms of expert and novice. Each category contains a number of statements that portray an aspect of student thinking.

The Personal Interest category examined how much importance the student placed on knowing and thinking about physics. The Real World Connection category was similar to the Personal Interest category, in that it tested the level of relevance which the student attributed to physics. Problem Solving (General and Confidence) examined student confidence and general problem solving aptitude, while Problem Solving (Sophistication) examined not only student confidence, but also whether students solved problems by memorization like novices or by starting with their understanding of physics, as experts do. The Sense Making/Effort category tested whether students were satisfied with their understanding of physics concepts.



The Conceptual Understanding category was very similar to the Sense Making/Effort category in that it examined whether students relied more heavily on memorization of equations or conceptual understanding, and the Applied Conceptual Understanding category included a few additional questions that related to the actual solving of physics problems.

The Diagnostic Tool and the CLASS pre-tests were administered on the first lab meeting, immediately after all students had signed the release forms required by the Institutional Review Board (IRB) for any study involving human participants. All students in the experimental and traditional sections took the tests, which took roughly 50 minutes to complete. At the end of the semester, the post-tests were given. The CLASS post-tests were administered during the final laboratory meetings. However, the Diagnostic Tool was administered during the final lecture meeting. This was because there is a two-week difference between the end of lab and the end of the course. Though the Diagnostic Tool pre-test was administered to all students, one of the traditional lecture instructors did not administer the post-test. This limited the amount of data available for analysis.

In addition to the CLASS, two other methods of assessment were chosen to evaluate student attitudes and behaviors. These were the Student Laboratory Evaluation Form (SLEF, see Appendix E), which offered the students an opportunity to candidly share their opinions about the laboratory, and a short, End-of-Course Questionnaire (EoCQ) which assessed several of the goals and outcomes that were not specifically addressed by the CLASS. These additional sources of data also offered triangulation, supporting and giving credibility to the results of the CLASS and Diagnostic Tool. The SLEF and the EoCQ also asked questions that were specific to the physics laboratory, which was the setting of this study.

The SLEF and the EoCQ were both unmatched tests, which means that the responses of individual students were not tracked. They were administered at the beginning of the final lab. Students were assured of anonymity, and these assessments were performed in the absence of the instructor or the graduate assistant. The instructor was not allowed to see the SLEFs until the final grades had been submitted. The completed forms were carried by a student to the office manager. They were then reviewed by the department chair and stored in the physics office. Copies were given to the instructor after grades were submitted, and become a tool by which the instructor identified which course preparation, class delivery, and grading practices either worked well or needed amending or replacement. Because submissions are anonymous and unsupervised, students were free to speak their minds about their laboratory experience.

The importance of the SLEF should not be minimized. Colleges and universities invest much time, personnel, and money into the process of student evaluations of faculty (Campbell, 2008). When I was a student, I was skeptical that these evaluations were meaningful or taken seriously. As an instructor, however, I realize the importance of frank student feedback. Because I teach nearly 100 students each semester, I have amassed a considerable stack of evaluation forms over the past few years.

Coding and analysis were performed on more than 700 SLEFs dating back five years in order to gather historical data about student attitudes and perceptions of the laboratory. Each form was evaluated for reoccurring or dominant themes in the written responses. Approximately one fourth of the forms were not helpful (for example, when the student commented “fine” or “ok” to all of the posed questions). However, much of the student feedback was serious and thoughtful, and three major response themes emerged during the

coding process: The pointlessness of the labs; the disconnect between laboratory and the lecture; and the “pickiness” of the grading scale. The SLEFs from the experimental and traditional laboratories were returned to me after final grades for all students were assessed, and these were then compared to historical data. The SLEF consisted of five, open-ended questions asked at the end of each semester, giving students the opportunity to express their beliefs of various aspects of the laboratory. These same questions have been asked of students since before 2002 and so there is a very large body of historical data with which to compare the results of the experimental laboratory, therefore increasing the dependability of the study.

Unlike the SLEF, the EoCQ (see Appendix F) was a first-time tool created by the researcher, with no associated body of historical data. This questionnaire was the third data source probing student attitudes and beliefs, providing data triangulation to corroborate and to add to the findings of the CLASS and the SLEF. The questions were worded to specifically reinforce the CLASS and the SLEF, and to address some of the attitudes and beliefs about lab that were not covered by either. The EoCQ helped to answer the questions of how much importance the students placed on their laboratory experience; how students valued the effort they expended in lab; the effectiveness of the lab to promote close and collaborative relationships between laboratory partners; and how much confidence students had in the labs to give them real insight into the experimental process. The 12 questions were not open-ended as were the SLEF questions, but were instead answered on a Likert-type scale from one to five.

In inquiry-based physics laboratories, student participation and collaboration are very important. Interactions between students were maximized by requiring that they work together in order to arrive at a conclusion. This type of collaboration helps to establish a social context which increases student interest and investment. Predictions were made collectively, and all data acquisition was performed as a group exercise. Although intuitively understood, these actions were very difficult to quantify. For example, how other than qualitatively do you evaluate whether the lab equipment was set up safely and efficiently, or that a student had demonstrated responsibility for her/his own learning by seeking help from instructors and other students, or that a student was functioning as a productive member of a group cooperating in lab learning tasks? In qualitative approaches, the researcher does not focus on assigning classroom events to categories, but instead attempts to “collect detailed descriptive information about them” (Good and Brophy, 2003, p. 19).

To assess this, observational data in the form of field notes and video recordings was recorded. Video analysis “has become a dominant part of research in classrooms” (Baker and Geren, 2007, p.191). In this study, instructor observations and video analysis were used to evaluate student/student and student/teacher interactions (see Appendix G). I chose to analyze the video qualitatively because, for one, the video data is “complex and contextualized, and... not easily reduced to numbers” (Richards, 2005, p.37). In fact, “data” is probably not the best word to use in regard to video, since many argue that video is better regarded as a source of data, out of which data can possibly be constructed, than as data in itself. Another reason for a qualitative analysis is that many of the above-stated goals and objectives of our laboratories are excluded from quantitative analysis because it was not easily quantifiable (Tobin, 2006).

These video recordings were also used to inform the weekly observational and reflective stages of the Action Research. One key consideration in video recording is to minimize the potential influence on the natural setting of the classroom (Johnson, Sullivan & Williams, 2009). In order to make the video recording as unobtrusive as possible, the camera was placed in the corner of the room, at the ceiling by a column. A wide-angle lens was used so that all students and interactions could be clearly seen. In accordance with IRB procedures, all students were informed of the intent of the research, and were assured that all video would be destroyed at the conclusion of the study. All students signed a release form which gave their specific permission to be video recorded, and in which they agreed that they understood the nature of my research.

Student/teacher interactions were also evaluated for reformed teaching practices, particularly the employment of Socratic dialogue. Socratic dialogue was introduced into the physics laboratory by Richard Hake, who reported that Socratic dialogue was helpful in moving first-year students from an Aristotelian worldview into the Newtonian world (Hake, 1987). Hake's idea was to have the students do simple Newtonian experiments that, when prompted with questions by the lab instructor, pose conflicts with the students' common-sense understanding, thereby generating even more discussion (Hake and Tobias, 1988). Conceptual understanding begins with conceptual conflict, which is raised by the Socratic dialogist and resolved through repetitive kinesthetic experimentation.

For example, the Behr Free Fall activity on acceleration features a carbon tape analysis of an object in free fall. Students must generate a position versus time graph. Using a data logging and graphing software called LoggerPro, students may fit a quadratic curve to these data and from that determine 'g' (a constant for the gravitational field near the surface

of the earth). The method of instruction for the traditional sections remained unchanged from previous semesters. The quadratic equation describing position as a function of time was written on the board, and the instructor explained in detail how to apply this type of curve fit to the position versus time data. Each constant and variable of the generic curve fit was explained, and students were told how to get 'g' from the formula. If something went wrong, the instructor would work on the problem while students sat by and watched, until it was solved so that the students could continue with the instructions. Even though they would get good results, the students were not engaged in coming up with the solution or the experimental design, and nothing was presented that would challenge their lack of understanding.

In the experimental sections, however, a totally different approach was taken. Students were not told on which axes to place position and time, which curve to fit to the data, or how to interpret the curve parameters once it was in place. Instead of step-by-step instructions, students were simply asked to graphically represent the motion of a falling object, then to model the data with an appropriate formula and explain what each parameter represented. The following is a segment of the type of Socratic dialogue that took place in this lab.

STUDENT: OK, I've shown the displacement of the shuttle after each time interval.  
Now what do I do?

INSTRUCTOR: Does the graph look as you expected?

STUDENT: Well, during each time interval, the shuttle was getting faster and faster, so the distance between the dots is always increasing. So yes, it looks right.  
But I still don't know what kind of curve to fit to the data.

INSTRUCTOR: OK, well what do you know about the relationship between distance and velocity? How might you describe this relationship mathematically?

STUDENT: Well, distance is velocity times time.

INSTRUCTOR: OK, and what type of equation is that?

STUDENT: It's a linear equation.

INSTRUCTOR: Would you like to try a linear fit? Do you think that will be a good match for your data?

STUDENT: No, it's definitely not linear! Why doesn't that work?

INSTRUCTOR: If this graph were linear, what would have to happen to the distance between each successive set of point?

STUDENT: Well, the distance would have to be the same for every time interval. But it's not because it's getting faster and faster. Right, so  $d = v t$  only works when the velocity is constant.

In the above example, the instructor continued to ask questions, never giving direct answers, until the student was able to negotiate past the particular misunderstanding. The questions posed by the instructor forced the student to broach a point that would have otherwise been avoided. If the student had simply been told to apply a quadratic fit to the position versus time data, this area of weak understanding would have never been addressed.

Using the Diagnostic Tool, the lecture grades, the CLASS, the SLEF, and the EoCQ, the results of the inquiry-based instruction were effectively assessed. The results of these assessments are given in Chapter IV.

## CHAPTER IV: RESULTS

### **Introduction**

In this chapter the findings of the various assessments are reported. The five methods of assessment were the Diagnostic Tool, the overall lecture grades, the CLASS, the EoCQ, the SLEFs, and the weekly video recordings.

### **Diagnostic Tool Results**

The scores and gains of the Diagnostic Tool are shown in Table 2. Of the 33 students in the Modeling-based sections, 19 were also in the experimental laboratory sections. Of the 41 students in the traditional section that administered the Diagnostic Tool post-test, 12 were also in the experimental laboratory sections. Historically, physics students at Appalachian have scored 45% on the FCI portion of the post-test, well below the 60% identified by Hake (1998) as the entry-level threshold of knowledge of physics concepts. Normalized gains have also been low, and 2008-2009 was an overall low year for Diagnostic Tool scores.



Table 2.

## Pre-test and post-test gains for the Diagnostic Tool

	Pre	Post	Gain	Normalized Gain
All Students (historical program data)	34	45	11	0.17
All 2008-09 students (74)	33	42	9	0.13
All Modeling-based section (33)	31	44	13	0.19
Experimental laboratory (19)	32	45	13	0.19
Traditional laboratory (14)	30	44	14	0.20
All Traditional section (41)	35	40	5	0.08
Experimental laboratory (12)	33	40	7	0.10
Traditional laboratory (29)	35	40	5	0.08

The “normalized gain” was suggested by Hake as an answer to the issue of “floor and ceiling” effects (Hake, 2006) that often arise in the analysis of pre- and post- testing. These are effects that appear when the test can be no less than 0% and no more than 100%. Floor and ceiling effects present a problem in quantifying learning gains because students with lower pretest scores have more room to improve than students with high pretest scores. For example, a student with a pretest score of 30% may potentially post a gain of 70% while a student with a pretest score of 80% may post a gain of no more than 20%. Because of this, there is a strong negative correlation between gains and pre-test scores, favoring those

students who have low pre-test scores. In response, the normalized gain  $\langle g \rangle$  is the ratio of the actual gain to the maximum possible gain.

$$\langle g \rangle = \frac{\text{posttest} - \text{pretest}}{100\% - \text{pretest}}$$

In Richard Hake's original study of over 6500 students at 62 universities, no correlation was found between normalized gain and pre-test scores, eliminating the effect of variance in pre-test scores.

As a way of classifying courses by normalized FCI gains, Hake determined three categories of effectiveness. "High-g" courses exhibited gain greater than 0.70; "Low-g" courses posted gains lower than 0.30; and "Medium-g" courses were anything in between (Hake, 1998, p. 65). The historical, normalized gains of physics students at Appalachian are 0.17, solidly in the "Low-g" classification. However, the normalized gains of the Modeling-based lecture have been uniformly higher than those of the traditional lecture sections. Though still Low-g by Hake's standards, students in the Modeling-based lecture section have historically posted more than twice the gains of students in the traditional lecture section.

In this study, a two-tailed t-test revealed a significant difference ( $p < .001$ ) between the Modeling-based section and the traditional lecture sections. However, a similar test showed no significant difference between the experimental laboratory and traditional laboratory students within the Modeling-based section or the traditional section.

### **Lecture Grade Results**

Analysis was also performed to determine whether the inquiry-based laboratories had any effect on the grades in the Modeling-based and traditional lecture sections. When laboratory grades were submitted to the course instructors, they were normalized to prevent

the higher lab grade average of the traditional laboratory sections from artificially inflating the lecture grades. With the lab grades normalized, course grades of students in the two traditional lecture sections were recorded. Of the 80 students in the traditional lectures sections, 32 were also enrolled in the experimental laboratory sections. A comparison of overall course grades shows no effect of laboratory section on grades in the traditional lecture (see Table 3). All grades are assessed on a 10-point grading scale.

Table 3.

Traditional lecture grade averages, categorized by laboratory section

	Grade Averages of Traditional Lab Students	Grade Average of Experimental Lab Students
Traditional Lecture #1	80	80
Traditional Lecture #2	84	84

However, the Modeling-based course grades reflect a significant difference between the performance of students in the experimental laboratory sections and students in the traditional laboratory sections. The experimental lab students posted a significant ( $p < .001$ ) 8-15 point improvement in all the measurable non-lab categories of the course (see Table 4). Factors leading to this grade discrepancy are discussed in Chapter IV.

Table 4.

Modeling-based lecture grade averages, categorized by laboratory section

Modeling Grade	Traditional Lab	Experimental Lab	Difference
Categories	Averages	Averages	
Overall Grade	71	80	+9
Homework	68	88	+20
Participation	75	82	+7
Class work	78	88	+10
Exams	66	77	+11
Final Exam	60	69	+9

### CLASS Results

In this study, the CLASS was administered in order to gather information about the development of student views on the nature and practice of science as compared to experts in the field. Because the CLASS was performed anonymously, scores were not matched and individual student performance was not tracked. Instead, pretest scores were normalized and average gains were calculated for both the experimental and the traditional sections. Table 5 summarizes shifts in the post-test favorable and unfavorable responses of the experimental and traditional laboratory students. A negative value in the favorable column indicates a shift toward “novice,” while a negative value in the unfavorable column indicates a shift toward the expert.

For example, the first row of Table 5 represents the “Overall” category. After a year of instruction, the favorable responses in the traditional labs declined by 5.9 points, while the number of unfavorable responses increased by 9.2 points. In the experimental sections, however, favorable responses increased by 2.6 points, and the number of unfavorable responses increased by only 3.9 points. The statements that make up each of the categories are listed in Appendix D.

Table 5.

## CLASS Shifts in Favorable and Unfavorable Attitudes and Beliefs

Categories	Favorable		Unfavorable	
	Trad.	Exp.	Trad.	Exp.
Overall	-5.9	2.6	9.2	3.9
Personal Interest	-13.4	-5.3	18.0	6.7
Real World Connection	-18.5	-10.9	16.6	7.2
Problem Solving General	-7.0	3.7	13.0	7.7
Problem Solving Confidence	-5.6	5.0	11.0	6.5
Problem Solving Sophistication	-2.4	7.2	13.4	5.3
Sense Making/Effort	-10.9	-5.8	8.9	9.3
Conceptual understanding	-4.3	7.1	9.9	3.5
Applied Conceptual understanding	-1.8	7.9	9.1	4.8

After a year of instruction, both the traditional and the experimental laboratories had increased in their percentage of overall unfavorable responses. However, while the traditional sections experienced a decrease in their percentage of favorable responses, the experimental

sections posted positive gains in that category. An inspection of the data indicated that the experimental sections had not regressed toward the novice as far as the traditional sections. To test the significance of this assertion, a two-tailed t-test was performed. Even though the standard deviations were large, the test indicated significant results in almost every category. The statistical results for the favorable responses are reported in Table 6, and the results for the unfavorable responses are reported in Table 7.

Table 6.

## Favorable CLASS responses

Categories	Traditional		Experimental		t-test values	
	<i>M</i>	<i>SD</i>	<i>M</i>	<i>SD</i>	<i>t</i> (158)	<i>p</i>
Overall	45.1	20.2	53.5	18.8	4.83	< 0.001
Personal Interest	36.8	29.7	45.0	31.2	2.52	< 0.02
Real World Connection	44.7	35.3	52.3	33.5	2.39	< 0.02
Problem Solving General	49.8	27.8	60.5	27.7	3.89	< 0.001
Problem Solving Confidence	54.3	34.2	64.9	32.3	3.48	< 0.001
Problem Solving Sophistication	34.8	26.8	44.4	29.5	3.02	< 0.002
Sense Making/Effort	53.9	27.6	59.0	28.8	1.71	< 0.1
Conceptual understanding	39.7	27.4	51.1	30.0	3.51	< 0.001
Applied Conceptual understanding	30.7	22.3	40.4	25.8	3.37	< 0.001

Table 7.

Unfavorable CLASS responses

Categories	Traditional		Experimental		t-test values	
	<i>M</i>	<i>SD</i>	<i>M</i>	<i>SD</i>	<i>t</i> (158)	<i>p</i>
Overall	29.0	15.5	23.7	12.1	7.17	< 0.001
Personal Interest	38.4	17.7	27.1	14.9	4.93	< 0.001
Real World Connection	27.6	30.5	18.3	26.9	10.52	< 0.001
Problem Solving General	23.6	30.2	18.3	20.1	3.81	< 0.001
Problem Solving Confidence	20.2	20.5	15.7	17.5	2.03	< 0.05
Problem Solving Sophistication	37.8	25.6	29.7	24.0	3.48	< 0.001
Sense Making/Effort	17.9	26.3	18.2	24.9	0.16	< 0.9
Conceptual understanding	32.9	18.9	26.5	20.0	3.17	< 0.002
Applied Conceptual understanding	41.9	24.5	37.6	22.4	1.91	< 0.1

With few exceptions, the results were statistically significant at the 0.05 significance level required for rejection of the null hypothesis.

### **SLEF Results**

The SLEFs (refer to Appendix E) of two semesters of experimental physics laboratories were compared to the traditional laboratories, both current and historic. A qualitative comparison was made possible by a rough coding of historical data. Dominant themes were extracted from student responses to the five questions. For the traditional laboratories, there was no thematic change from previous semesters. As student responses

were grouped, it became apparent that the three most dominant were the correlation between lab and lecture, the relevance of lab, and the grading process.. Below are examples of typical student comments associated with each theme.

#### Traditional SLEF Theme 1: Disconnect between lab and lecture

- “Did not see close connection between lab and class.”
- “Doesn’t really help with the lecture material.”
- “Did not correlate with the course.”
- “How can we be expected to be quizzed on something we haven’t even covered in class?”
- “The lab stayed consistently ahead of the lecture.”

#### Traditional SLEF Theme 2: Lack of relevance of traditional labs.

- “Labs are pointless!”
- “Cookie cutter labs -- very boring!”
- “Somewhat pointless and did not help me in understanding the course material.”
- “The lab seemed like busy work.”
- “(Labs were) mostly a waste of time... Very elemental.”

#### Traditional SLEF Theme 3: The arbitrary pickiness of the grading scale

- “Too many points taken off for sig figs!”
- “I would have made 100 every time if not for units.”
- “Lab should focus on practicing things we learned in class, not on a bunch of picky stuff like estimated error and units.”
- “I never really understood how to use significant figures.”



- “Way too many points taken off for picky stuff! I would feel good about what I learned in lab and then lose a bunch of nonsense points because of the write-up!”

The student responses on the experimental SLEFs, however, were markedly different. They contained almost no mention of any disconnect between lab and lecture, the irrelevance of the labs, or the pickiness of the grading scale. Instead, two new dominant themes emerged from a coding of the experimental SLEFs. First, students complained that labs were difficult to understand. Secondly, students in the experimental sections did not seem to think that laboratory instructor was very helpful.

Experimental SLEF Theme 1: Difficulty with open-ended instructions.

- “Spent most of the lab period just trying to figure out what to do.”
- “Need more clear instructions! I am lost all the time!”
- “Would like to have step-by-step instructions. I know it’s an experimental lab and is supposed to be better, but it’s just not working for me.”

Experimental SLEF Theme 2: Instructor not forthcoming with information.

- “Was not helpful at all. Answered questions with a question.”
- “Should have spent more time going over the concepts.”
- “What method of instruction? Did not teach at all, we had to learn everything on our own.”
- “Knowledgeable, but not very forthcoming. Expected us to know more than we did.”
- “Didn’t really teach. We wasted half the lab trying to figure it out on our own.”

## EoCQ Results

The EoCQ (see Appendix F) was a set of questions generated by the researcher. Though not validated, these questions complemented the findings of the CLASS, and also provided insight into several issues that the CLASS did not specifically address. Students responded to a 12-item, Likert-type survey (1 = Strongly Agree; 2 = Agree; 3 = Neutral; 4 = Disagree; and 5 = Strongly Disagree). Some of the statements were worded positively, and some negatively. Statements 1, 5, 6, and 10 were negative statements, and responses to those were reversed before their inclusion in the analysis. Responses were analyzed using a two-tailed t-test, the results of which indicated that the experimental sections ( $M = 3.33$ ,  $SD = .95$ ) had significantly more positive attitudes about physics lab than did the students of the traditional laboratory sections ( $M = 3.15$ ,  $SD = 1.09$ ,  $t(158) = 2.21$ ,  $p < .05$ ). Figure 3 and Table 8 compare responses for each item, with higher values indicating more positive responses.

Figure 3.

Responses to the End-of-Course Questionnaire

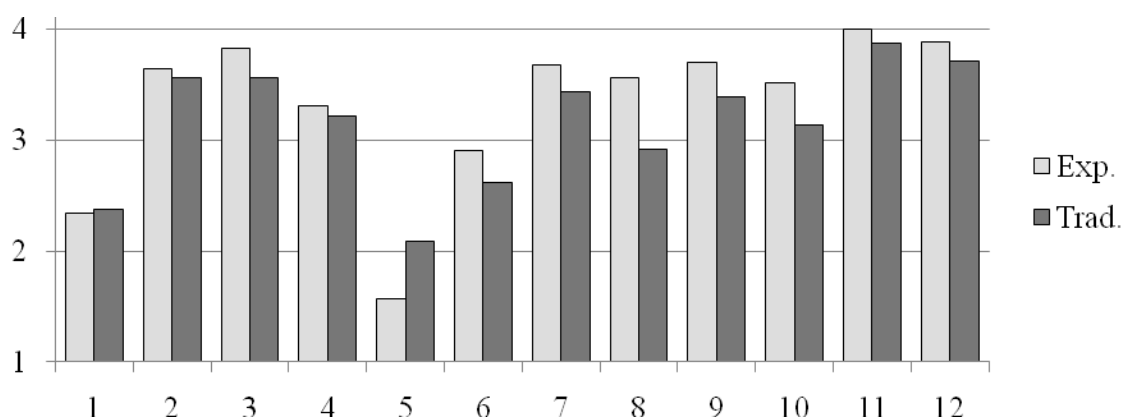

Table 8.

## Results of the End-of-Course Questionnaire

STATEMENTS	Traditional		Experimental		t-test values	
	<i>M</i>	<i>SD</i>	<i>M</i>	<i>SD</i>	<i>t</i>	<i>p</i>
1. (Reversed) It was difficult to complete the lab exercises in the allotted time	2.37	1.27	2.34	1.13	0.36	< 0.8
2. My lab experiences have been very interesting	3.56	1.06	3.64	1.15	0.68	< 0.5
3. I had to work hard during the lab	3.56	1.05	3.83	0.80	6.24	< 0.001
4. I enjoyed the lab exercises	3.21	1.15	3.30	1.15	0.77	< 0.5
5. (Reversed) It was difficult to understand the lab procedures	2.08	1.08	1.57	1.28	3.66	< 0.001
6. (Reversed) The lab is the least important part of this course	2.62	1.07	2.91	0.88	4.59	< 0.001
7. I learned a lot from the lab exercises	3.43	1.10	3.68	0.85	5.25	< 0.001
8. I enjoyed working with the computer-interfaced equipment	2.92	1.22	3.57	1.03	8.33	< 0.001
9. The lab helped me learn physics	3.38	1.10	3.70	0.91	4.77	< 0.001
10. (Reversed) The procedures made it difficult for me to work with partners	3.14	1.03	3.51	0.54	5.63	< 0.001
11. The lab procedures made me think	3.87	0.99	4.00	0.78	2.62	< 0.01
12. The lab helped me understand how the experimental process really works	3.71	0.92	3.89	0.91	2.00	< 0.05

## **Video Analysis**

Throughout the course of two semesters, I recorded all the sections that I taught. An analysis of the video gives a rich and consistent view of the laboratory environment from week to week. The traditional laboratories were very structured, with students following the directions in the manual in order to reach the desired result. Student-student interactions were limited to delegating tasks and acquiring data. In contrast, the experimental laboratories teemed with movement and conversation. The experimental lab students took more time setting up the equipment and planning the experimental procedures. During this time, student-student interactions were at a maximum as they tried to work out the best way to achieve the goals of the activity.

Students in the traditional laboratory displayed a lower level of interest and motivation than the students of the experimental sections. They were less likely to experiment with the apparatus, and more likely to leave once data were collected to perform the analysis at home. The experimental sections, however, were less sure of their procedures and were more likely to perform an analysis as a group during lab time in order to make sure that their results were valid. Although they displayed higher levels of frustration, they also exhibited greater camaraderie and teamwork.

Early in the semester, students in the experimental sections seemed confused on how to use the equipment to acquire data that would achieve the goals of the laboratory, and also timid about handling the equipment. As the semester progressed, however, they lost their fear of setting up and experimenting with the apparatus, and also became proficient at developing a plan for collecting useful data. This culminated with the final lab, the practicum, which was unique to the experimental labs. This lab required the students to design the experiment from

the ground up, requesting their own equipment, and developing their own method of collecting data. During this lab there were none of the signs of frustration that characterized the earlier weeks of the semester, and the students were focused and engaged from beginning to end.

## CHAPTER V: Discussion

### **Introduction**

This chapter examines the findings of the study and describes the analysis that was performed on the data. The effectiveness of inquiry-based reform through Action Research is evaluated using the results of the Diagnostic Tool, the lecture grades, the CLASS, the EoCQ, the SLEFs, and observations from the video recordings. The limitations of the study are considered and the conceptual framework is revisited. The implications of the results are discussed, both for the researcher and for the community of laboratory instructors and directors. The continued, post-study Action Research is described, and areas of future research are suggested.

### **Analysis**

The scores of the Diagnostic Tool seem to indicate there were no significant differences between the traditional and experimental sections in terms of increasing student understanding. Twenty of the thirty-four questions are based on the FCI and deal with the force concept, while the rest examine other concepts. The overriding factor seemed to be whether or not the student was in the Modeling-based lecture section, independent of laboratory section.

Although the overall test average revealed no significant difference between the experimental and the traditional sections, an item-by-item analysis of individual questions was more informative. As a follow-up analysis of this study, Dr. Allen and I collaborated on a paper that examined, in depth, the individual questions posed by the Diagnostic Tool. (Allen and Cockman, 2009). For example, the traditional laboratory students outperformed the experimental laboratory students on two questions that dealt with the path an object takes after a kick delivers an impulse to the object. On examination of how the two sections differ, it was noted that the traditional sections performed two-dimensional collisions using air pucks on an air table, while the experimental sections did the same experiment using air hockey discs on the floor. As it turns out, the floor in the physics lab is uneven, and the paths of the air hockey discs tended to curve after the collision. For this reason, the experimental laboratory students were more likely to believe that an object took a curved path, rather than a straight one, after the impulse was delivered.

The results of this study were worked back into to ongoing cycle of Action Research. Informed by the item-by-item analysis, the activities which were determined to have contributed to a strong distracter on certain missed questions were revisited and modified. Also, new activities were planned that were intended to specifically address gaps in student knowledge as determined by incorrect responses to the Diagnostic Tool. As this cycle repeats on a yearly basis, the laboratory QuickGuides will become increasingly focused and purposeful.

An analysis of overall lecture grades showed no difference between experiment and traditional laboratory students who were in the traditional lecture section. However, the experimental lab students enjoyed a significant grade advantage in the Modeling-based

lecture. It is quite possible that the similar work environment between the experimental lab and the Modeling-based lecture provided positive reinforcement for the students of both. The two were compatible in that students are continuously immersed in an atmosphere where learning is student-centered and inquiry-based. The Modeling style of instruction is difficult for some students to understand at first, with a learning curve similar to that faced by the students of the experimental laboratory during the first half of the Fall semester. The combined effect, however, may have helped those students to become more quickly acclimated to an inquiry-based teaching style. The activities performed in the experimental laboratory were also reinforced in the Modeling-based lecture, and these students were perhaps more likely to buy into this method of instruction because they experienced it five hours each week instead of only three.

Despite the dramatic difference in grades in the Modeling-based lecture section, it is apparent that any gains attributable to the experimental laboratories were not assessed in such a way as to translate to a grade differential in the traditional lectures. It may be that, unlike the Modeling-based lecture, the traditional lectures do not assess the ability to plan and carry out experimental procedures, work collaboratively in groups, or reduce and interpret data. I hesitate to draw conclusions from the overall course grade data. There are many factors that affect overall grades, and the sample size of the traditional sections was limited because one of the traditional lecture instructors did not administer the Diagnostic Tool post-test. Further research, including more data and a deeper analysis, is required before the discrepancy in overall grading is fully understood.

The most significant quantitative results of this study were found in an analysis of the attitudes and beliefs of introductory physics students. These were assessed using the CLASS,



the EoCQ , the SLEFs, and the video recordings. After a year of instruction, the students of the experimental sections were more self-motivated and more responsible for their own learning, better at collaborative problem-solving, and more likely to give an expert response concerning physics relevancy and problem-solving.

An analysis of the CLASS revealed that the traditional laboratory sections were less optimistic about the value of physics and its role in their personal lives. They were also less confident in their problem solving abilities than the experimental sections, and tended to solve problems by memorization like novices rather than by starting with their understanding of physics, as experts do. The experimental sections not only increased in their confidence in their abilities as scientists, they also saw clearer relationships between mathematical formulae and measurable quantities, and also expressed a greater optimism that nearly everyone is capable of understanding physics if they work at it.

Responses of the experimental laboratory students may have become less novice-like after two semesters of instruction because the experimental laboratory offered a setting that more closely modeled real scientific research. Students of the traditional laboratories seemed to know and expect that their experiments were rote exercises that should work correctly every time if performed according to the instructions. In contrast, the students in the experimental laboratory sections approached each laboratory as an unknown problem that must be solved collectively and thoughtfully, or else there was a real possibility of failure and of obtaining no meaningful results at all.

The EoCQ results indicated no statistical difference between sections on the difficulty of performing the activities within the allotted time, and all sections found the labs similarly enjoyable. However, the experimental sections worked much harder than the traditional

sections, and placed a higher value on the importance of lab. The experimental sections felt more strongly that they were learning physics from the laboratory activities, and that the laboratories facilitated a more collaborative atmosphere. These findings supported the analyses of the CLASS, indicating the greater effect of the experimental laboratories on student attitudes and beliefs. Student responses also indicated a very strong correlation between the experimental sections and enjoyment of working with the computer-interfaced equipment. This was perhaps because of the playtime built into the laboratory activities, as contrasted with the step-by-step instructions found in the traditional laboratory.

The coding of the SLEFs showed that the experimental sections did not have a problem when the subject material of the laboratory and lecture did not coincide. It is almost impossible to synchronize the subject material of the laboratories with all sections of lecture, since all three lecture sections are taught using different instructional styles and are therefore differently paced. Rarely, if ever, are all three professors teaching the same subject simultaneously. Also, equipment conflicts sometimes cause labs to be staggered across courses, with priority given to the calculus-based course, and so it is sometimes difficult for the algebra-based sections to perform a lab in the same week in which the topic is covered in lecture. Though the students of the experimental sections do not seem to consider this a foremost problem, dissatisfaction with this disconnect was one of the primary themes of the traditional laboratory. This was typical of traditional laboratories perhaps because students were not actively engaged in the design process. In the traditional laboratories, step-by-step instructions are followed and results are obtained, but little meaning is conveyed to the student. This theme reinforced the findings of the CLASS and the EoCQ in that it shows a decline in the student's confidence that actual learning has taken place.

Historically, however, discoveries in the laboratory have preceded theory, and labs should not have to align with lecture in order to provide meaning. Conceptual understanding may be developed in the laboratory setting without going to great pains to harmonize each laboratory with each section of lecture (Bergquist, 1991, Trumper, 2002). In fact, inquiry advocate Joseph Schwab (1960) argued that science teachers should use experiences in laboratory as an introduction to scientific concepts and principles, with the laboratory leading the lecture. If one believes in the process of inquiry to learn science subject matter, it would follow that the laboratory is the appropriate place for an introduction to every topic.

Another area that presented problems for the traditional sections, but not the experimental sections, was the grading scale. The fill-in-the-blank nature of the traditional activities and the written reports generally resulted in artificially inflated grades with little deviation. Students of the traditional laboratory sections felt that they were not being properly assessed on what was actually learned in lab, and were also angry that such a large portion of their missed points each week resulted from improper use of significant figures, estimated error, and units. Because of the cookbook instructions, graders were unable to assess student ability to plan and design a successful experiment. The only real way to distinguish between students was to give disproportional weight to minor technicalities. This led students to believe that lab grades were based on “picky” or arbitrary criteria. The fact that the experimental laboratory students had no complaint with the grading scale may be due to the strength of the goals-based grading rubric, and to the reduced emphasis on significant figures.

The results of the SLEFs from the experimental laboratory sections were equally revealing, indicating a shift in emphasis from the tediousness of creating reports to the

frustration of student-centered experiment design. These SLEFs showed that the students of the experimental laboratories were dissatisfied with their comprehension of the laboratory procedures and the helpfulness of the laboratory instructor. This was reinforced by EoCQ, in which showed that experimental sections expressed a greater difficulty of interpreting the laboratory procedures. However, because the experimental sections were unguided and open-ended, these would be more difficult to understand than the traditional cookbook versions. The open-ended laboratories were difficult to perform precisely because the experimental design was left up to the student. Learning physics by inquiry required that students learn to rely on your own thoughts and ideas, and complaints about this type of difficulty are typical of an inquiry-based curriculum (Laws, Roseborough, & Poodry, 1995, Sadaghiani, 2008). For this reason, it is important to for instructors communicate to the students the reasons behind accepting and sharing responsibility for their own learning.

If students understand that minimal instruction is actually best for their learning and understanding of the subject, then there will be fewer future complaints about this method of instruction. This may be achieved by working harder to explain the researched-based arguments for this type of instructional approach. Perhaps with a little more transparency about the goals and objectives of laboratory, students can understand that open-ended activities, guided by Socratic questioning, is a preferred method of learning. If so, students may be willing to display more patience and less frustration during the first difficult few weeks. This is one of the goals of the ongoing Action Research that will be enacted during upcoming semesters.

Although students used the SLEFs as a vehicle to express their frustration with procedural comprehension, an analysis of the weekly video recordings brought out a richer

story. As my methods of laboratory design and instruction were refined through the process of ongoing Action Research, I was able to better interpret the interactions I observed in during the next lab meeting and on the video recordings. And, as my own understanding of inquiry-based instruction progressed throughout the course of the semester, my perceptions of what was taking place in the laboratory changed as well. The traditional laboratories, which seemed more efficient and structured at first, began to appear increasingly rote and stagnant. Because our traditional laboratories were smooth and well-oiled, the those videos was uninteresting to me. There was very little interaction between partners as compared to the experimental sections. The only real student planning that took place was to decide who would do what job (measuring, timing, typing, etc.).

The experimental sections, however, were vibrant and exciting. What at first appeared to be a loose cacophony of movement and sound in the experimental laboratories soon coalesced into meaningful communication and content-rich interactions. Students were brainstorming to come up with an appropriate design to answer the question, discussing which direction to take and which equipment to use. Predictions were being argued and observed phenomena were being collectively interpreted. Instead of sitting idly at the front of the class while the students stepped through a sequence of instructions, the instructors were constantly moving from station to station, engaging in dialogue and listening to students describe their design plans and their experimental processes.

### **Revisiting the Conceptual Framework**

The conceptual framework of this study presented justification for the use of Action Research to inform the weekly development of inquiry-based laboratory activities, and also

for the administration of the various assessment tools in order to analyze the more tangible aspects of physics laboratory reform. The results confirmed Action Research as an effective, real-time method of performing and evaluating inquiry-based reform without the need for extensive up-front planning or an arduous search for a best-fit curriculum.

These assessments proved to be indispensable tools for determining the success of the inquiry-based intervention, but the real story is about what happened weekly as I engaged in Action Research. Many hours were spent planning activities, writing the QuickGuides, watching videos of my own instruction, and recording my observations. After each week of instruction, I spent several hours reviewing the interactions between myself and students. More than 72 hours of video were reviewed, providing insight into student/student collaborations and student/teacher interactions. This process not only provided a second vantage point for my observations, it aided the weekly reflective stage that is critical to performing Action Research. Appendix G contains an instructor journal of these observations and reflections.

At the end of each week, I reflected on the successes and failures, learning from my triumphs as well as from my defeats. I then used this knowledge to create the next week's QuickGuide and plan the experimental laboratory activities. Just as collaboration benefits students, I also benefited from collaboration with my PER group, the graduate assistants, and others. It is important for any researcher to reach out to others who have expertise, knowledge, or just a different perspective on the subject being researched. Through collaboration and research, I enhanced my teaching skills and methods, and the quality of the physics laboratory.

## **Importance of Study**

As outlined in the introduction, the progressive agenda of science education reform places substantial intellectual demands on teachers to promote student inquiry (NSF, 1993), leading to considerable resistance to a change in teaching style within the science community (Brainard, 2007; Sunal et al., 2001). It is clear that further study in a variety of school contexts and environments is required to expand our understanding of what constitutes good teaching and learning in physics (Geelan, Wildy, Loudon, & Wallace, 2004). Action Research by university educators is one method that improves the materials educators currently use to teach based on what is known about how people learn (Staten, 1998, *Classrooms as Laboratories*, 2001). Although there have been studies on the effectiveness of various types college-level curriculums (RTP, for example), this study was innovative in that it used Action Research as a form of inquiry-based laboratory reform (Feldman, 1996).

Another real need in PER is a method of implementing inquiry-based research in a way that not only affects student learning and understanding, but that actually changes the general educational environment of the institution wherein the intervention is taking place (Hammer, 1999, Wenning & Wenning, 2006). This dissertation study was not merely a test of an inquiry-based curriculum; it was an exercise in Action Research that affected permanent change in me as a researcher, as an instructor, and as a contributing member of the physics department. Because I am in a position to influence the learning and teaching atmosphere, I am able to impact the political and pedagogical barriers to reform at both local and national levels. This study has in fact shown that Action Research is not only a viable method enacting a curriculum for inquiry in an educational environment that is prohibitive to inquiry-based reform (Feldman and Minstrell, 2000), it is also a method of convincing others

to first appreciate, then emulate, the methodology leading to effective and lasting change (Sunal et al., 2001, Brainard, 2007).

### **Limitations**

One of the major limitations of this study is that it sought to effect change in the laboratory only, not in the course as a whole. In perspective, the laboratory only accounts for 15% of a physics student's overall grade. In order for inquiry-based reform to be fully realized throughout the course, changes must be made in the traditional lecture as well. This research suggests that changes in the laboratory alone are not sufficient to affect a great increase in Diagnostic Tool scores. However, it did present a promising outlook for the marriage of inquiry-based labs and the Modeling-based lecture. In this instance, the inquiry-based laboratories played a strong supporting role, increasing the effectiveness of the lecture section and leading to greater student learning.

Another aspect of this study that is conventionally listed as a limitation is that it was designed and carried out by a first-time educational researcher for the purpose of a doctoral dissertation. I recognized my lack of experience in inquiry-based instruction. While inexperience may be a limitation in terms of the quality of instruction, the fact that I was a relative novice becomes a strength in showing the effects of first-time, inquiry-based intervention through Action Research. This type of methodology benefits all levels of researchers, from novice to expert. One of the goals of this study was to determine whether inquiry-based reform research could be interjected into a traditional educational environment. The success of this study should be an encouragement to other first-time researchers who would like to enact inquiry-based reform at their own institution in a way that will maximize



their strengths as educators and produce a measureable impact on their students. As practice continues and experience increases, the success of these reforms will also continue to grow.

### **Implications**

In the third chapter, I entered into a multi-faceted discussion of the roles that I assume in relation to this research project. Over the course of this study, those roles have been enhanced and altered, reflecting my own personal and professional growth. This study marked my progression from novice to expert in the area of Action Research in PER, and as such has directly impacted several key roles that define who I am as a person and as a researcher.

My role as Director of Laboratories has been greatly strengthened and expanded. I have moved beyond being merely the one in charge of rotating labs. This study has had a direct effect on my own pedagogical philosophy, effecting the decisions I have and will make about the future of physics laboratory instruction at Appalachian State. As an active educational researcher, I now have the role as the developer of new laboratory activities based on solid research performed by myself. I also have the ability to assess the effectiveness of these activities, using Action Research to inform each step in the developmental process.

I have also strengthened my role as a supervisor, both of the instructors and graduate students who will ultimately apply the laboratory reform, and of undergraduate assistants and workers who will be setting up labs and assisting other professors in lecture. As this role has increased, it has been recognized by other members of the Department of Physics and Astronomy. As such I have been entrusted with increasingly greater teaching, supervisory,

and committee responsibilities. As I take on greater responsibility, I have begun to exert a greater influence on the educational environment of this department by introducing more inquiry into the physics laboratory.

This research project has generated interest in educational reform, and has served as a method of educating my peers about the methodological options available to them as lecturers and laboratory instructors. As these changes in the algebra-based laboratories are modified and placed into effect in the calculus-based sections, it is expected that the abilities and the levels of expectation and our majors will be increased. This will have a direct influence on student performance in upper-level laboratories, seminars, and faculty-led research projects. This increase in the quality and the expectations of our majors will need to be accounted for by changes in these higher level offerings, and it will be my role to encourage inquiry-based research at all levels. Because I am increasingly responsible for resource planning and allocation in the department, I will now be able to use the data from this study to inform what new equipment to acquire and what new activities should be developed. This will directly influence the educational environment, creating a setting that is structured toward an inquiry-based style of instruction.

Because of the positive results of this study, I was able to make a case for the full implementation of inquiry-based labs. Drawing from experience gained during the 2008-2009 school year, I made appropriate revisions to the desired goals and outcomes, as well as to the QuickGuides and the grading rubrics. These revisions were based largely on the question-by-question analysis of the Diagnostic Tool. The specific activities that led to lower scores on individual Diagnostic Tool questions were redesigned, to significant results. At the

end of the spring 2010 semester, students of the algebra-based sections posted the highest average test scores recorded since the Diagnostic Tool has been in use at Appalachian.

Due to the successes of the algebra-based section, the door is now open for this same study to be repeated in the calculus-based laboratory during the 2010-2011 school year. Although there is considerable faculty resistance to any type of change in the laboratories performed by our majors, it is clear that change is needed. This study establishes conclusively that inquiry-based reform through Action Research is a proven vehicle for positive change in our department at the algebra-based level.

Along with the laboratories, there are also implications for the lecture sections. The results indicate that there is a strong correlation between the inquiry-based laboratories and the Modeling-based lecture. This study supports PER findings that there is need for reform in the traditional lecture in order for the effectiveness of the inquiry-based laboratory to be maximized (Thornton and Sokoloff, 1996). Internal resistance from traditional faculty and the pressure of first-time success are real inhibitors of the enactment of physics education research (American Association for the Advancement of Science, 1990). The success of this study should be instrumental in convincing traditional faculty that curricular changes would benefit students.

One way that the laboratory is already impacting lecture is by dictating which topics get covered in the introductory sections. Studies have shown that depth of instruction is to be preferred over coverage of a broad range of topics (Schmidt, McKnight, & Raizen, 1997). Because specific laboratory activities have been shown to result in an increase in Diagnostic Tool, these activities are emphasized while others are left out. A dated list of topics covered in the laboratory was disseminated to the lecture professors, who were encouraged to align

the timing of their instruction with the planned laboratory activities. This will result in substantial depth of coverage in the areas of motion, force, energy, and momentum in, in which both lab and lecture should further increase Diagnostic Tool scores.

Another of my roles that has been altered by this study is that of researcher and member of a local and global PER community. Having experienced first-hand the benefits of inquiry-based reform and of Action Research, my role in my local PER group has moved from a passive listener to an important source of input and a resource of expert information. This research project has strengthened and energized my PER group, and the research that extends from this study should result in multiple presentations and publications by members of our group. I have gained much knowledge and experience, and have become more expert in the application of inquiry-based reform.

In addition to infusing energy into my own local PER group, this study has contributed to the larger PER community. The results of this study show a positive relationship between inquiry-based reform in the laboratory and the improvement of student attitudes and beliefs, leading to implications for any instructor or laboratory director who wants to make an improvement in this area. The results of this research have been disseminated in poster sessions at the 2009 American Association of Physics Teachers meeting in Chicago, IL, and at the 2010 meeting in Washington, DC. The study generated interest and was well received, and I have since been in communication with other educators and administrators who wish to positively affect the attitudes and beliefs of introductory physics students.

## **Ongoing and Future Research**

Action Research is an ongoing, seemingly never-ending cycle. Whether it is an hourly cycle, in which changes to the QuickGuides are made between laboratory sections, or a yearly cycle, in which changes to the goals and outcomes of the previous year are revisited, Action Research will continue to demand further and ongoing research. Several specific areas of research are currently being explored as a direct result data gathered during the previous year. These considerations will be applied to the algebra-based section, and also used in the development of the experimental, calculus-based section. Based on an analysis of item-by-item responses to the Diagnostic Tool, QuickGuide activities are being modified and created. In order to strengthen concepts, pre- and post-lab laboratory activities are being planned which tie in strongly with the proposed goals and outcomes.

As a result of the SLEF data, methods are being sought which engender a greater buy-in by students. For example, a more detailed laboratory syllabus will be produced, and each lab will have its own set of concrete goals and objectives. Based on the results of this study, I have concluded that further Action Research and inquiry-based laboratory development is necessary in order to continue to increase the quality of our undergraduate laboratory experience. One area that is slated for immediate research that of CLASS analysis. Because the CLASS results highlighted the most significant benefits of the enacted reform, a more in-depth analysis will be performed which spans multiple years. Already data has been collected for the 2009-2010 school year, and a paper on the subject is planned for the fall of 2010. CLASS posttests and normalized gains will be compared to national scores, and student responses to each item will be examined.

An analysis of the CLASS data shows that much is yet to be done to improve the way that our students think about physics. Changes to instruction will be suggested that should have the effect of not only stemming the slide of first-year students toward the novice response, but of actually moving them away from the novice and into the expert region. For example, two areas that did not show significant improvement were Personal Interest and Sense Making/Effort. Because of this, effort will be made to design QuickGuide activities that are more grounded and relevant to our students, and that rely less on rote memorization of textbook formulas.

The implications discussed in the previous section now directly influence the direction of future research. As the Action Research cycle continues on an even larger scale, the reflections of our PER group have led to major changes in our laboratory curriculum. These changes need to be passed on to other instructors in the form of teacher education. In order to train instructors and graduate assistants in the use of Socratic dialogue and to introduce them to the idea of using Action Research as a method of instructional improvement, Dr. Allen and I have developed a teaching methods seminar that is required of all graduate students. Each week we meet with all instructors to reflect on that week's instruction, and to engage everyone in the planning process for the following week. By collecting the observations and opinions of all instructors, we will be able to make better-informed decisions about which activities were successful and which require additional development.

The involvement of other faculty in Action Research is critical. Beginning the Spring semester of 2011, we will be planning and enacting two experimental sections of the calculus-based laboratory. This lab is three hours in length as compared to the two-hour

algebra-based labs, and the content of the course is more analytical. As such, the QuickGuides must be modified to reflect these differences. This will require a revision of the desired goals and outcomes, and the inquiry-based reform effort will be informed week to week by the ongoing Action Research. This will be done with the assistance of another faculty member, Dr. Scott Thomas, who will also be teaching the lab. Guided by the research already performed in the algebra-based sections, he will conduct research and actively participate in the weekly discussions of our PER group. As time continues, it is hoped that the circle of our local PER community will continue to widen, and that more Action Research projects will be planned and carried out.

In addition to the laboratory reform, workshops are being planned that will give lecture instructors the opportunity to learn and practice non-lecture-based activities to use during regular class time. Undergraduate physics majors will be trained to operate Vernier probes and sensors, as well as Logger Pro graphing and video analysis software. These students will then be available to assist faculty in performing Interactive Lecture Demonstrations (Sokoloff and Thornton, 1997) in the classroom. During the Fall semester of 2009, I began teaching the lecture section of algebra-based introductory physics for the first time, which opened my eyes to the challenges of teaching inquiry in the classroom. This new perspective now informs the planning and timing of the laboratory activities.

Two other areas are suggested for future research. One is the creation of an Action Research Workshop as a method of faculty development. This workshop would seek to increase faculty awareness of inquiry-based reform research and introduce them to the use of Action Research as a method for improving instruction and enlarging the existing body of physics education research. Also planned is a more in-depth analysis of the Diagnostic Tool

to identify the major distracters in incorrect student responses to each question and suggests ways to modify instruction in order to increase gains in conceptual learning. As the lecture portion of the course is transformed, further research may be performed that analyzes the combined effects of laboratory and lecture on student conceptual learning.



## WORKS CITED

- Adams, W., Perkins, K., Dubson, M., Finkelstein, N., and Wieman, C. (2004a). The design and validation of the Colorado Learning Attitudes about Science Survey. *Proceedings of the 2004 Physics Education Research Conference*, AIP Proc No 790.
- Adams, W., Perkins, K., Pollock, N., M., Finklestein, N., Weinman, C. (2004b). Correlating student beliefs with student learning using the Colorado Learning Attitudes about Science Survey. PERC Proceedings.
- Adams, W., Perkins, K., Podolefsky, N., Dubson, M., Finkelstein, N., and Wieman, C. (2006). New instrument for measuring student beliefs about physics and learning physics: The Colorado Learning Attitudes about Science Survey. *Physics Review Special Topics Physics Educational Resource*, 5, 010101.
- Adey, P., Shayer, M. & Yates, C. (1989). *Thinking Science: The Curriculum Materials of the Cognitive Acceleration through Science Education (CASE) Project*. Surrey: Thomas Nelson and Sons Ltd.
- Aikenhead, G. S. (1982). The content of STS Education. *STSRN Missive*, 2(4), 17-23.
- Alexopolou, E. & Driver, R. (1996) Small group discussion in physics: peer interaction modes in pairs and fours. *Journal of Research in Science Teaching*, 33, 1099-1114.

- Allen, P. and Cockman, J. (2009). The "RIPL" effect on learning gains in lecture. *Physics Education Research Conference, 1179*, (73-76).
- American Association for the Advancement of Science (1990). *Science for all Americans: Project 2061*. New York: Oxford University Press.
- Ansbacher, T. (2000). An Interview with John Dewey on Science Education. *Physics Teacher*, 38(4), 224.
- Assessment Performance Unit (1988). *Science at Age 13, review report* (London: DES).
- Arons, A. (1972). Toward wider public understanding of science. *Am. J. Phys.* 41(6): 769-782.
- Arons, A. (1983). Achieving wider scientific literacy, *Daedalus*, Spring.
- Arons, A. (1993). Guiding insight and inquiry in the introductory physics laboratory. *The Physics Teacher*, 31, 278-282.
- Arons, A. (1996). *Teaching Introductory Physics*. New York: Wiley.
- Axelrod, A. (1999). *The complete idiot's guide to 20th century history*. New York: Alpha Books.
- Baker, W., & Green, J. (2007). Limits to certainty in interpreting video data: Interactional ethnography and disciplinary knowledge. *Pedagogies: An International Journal*, 2(3), 191-204.
- Barnett, J. & Hodson, D. (2001). Pedagogical context knowledge: toward a fuller understanding of what good science teachers know. *Science Education*, 85, 426-453.
- Beichner, R. J., Saul, J. M., Allain, R. J., Deardorff, D. L., & Abbott, D. S. (2000). *Introduction to SCALE-UP: Student-Centered Activities for Large Enrollment University Physics*. Paper presented at the American Association for Engineering

- Education. from [http://www.ncsu.edu/ncsu/pams/physics/Physics\\_Ed/Articles/01ASEE\\_paper\\_S-UP.pdf](http://www.ncsu.edu/ncsu/pams/physics/Physics_Ed/Articles/01ASEE_paper_S-UP.pdf).
- Bergquist, W. (1991). Role Reversal: Laboratory before the Lecture. *Physics Teacher*, 29(2), 75-76.
- Bollag, B. (2007). A Top Physicist Turns to Teaching. *Chronicle of Higher Education*, 53(23), 1-8.
- Brainard, J. (2007). 50 years after Sputnik, America sees itself in another science race. *The Chronicle of Higher Education*, 54(7), 22.
- Brekke, S. E. (1995). Changes in the physics curriculum in American high schools from Revolutionary War to the present. U.S. Educational Services document, ED 393 655.
- Brewe, E., Kramer, L., and O'Brien, G. (2009). Modeling instruction: Positive attitudinal shifts in introductory physics measured with class. *Physics Review Special Topics Physics Educational Resource*, 5(1):013102+.
- Brna, P., & Burton, M. (1997). Modelling Students Collaborating while Learning about Energy. *Journal of Computer Assisted Learning*, 13(3), 194-205.
- Brown, D. E. (1989). Students' concept of force: the importance of understanding Newton's third law. *Physics Education*, 24(353-358).
- Bruner, J. (1960). *The Process of Education*, Cambridge, Mass.: Harvard University Press.
- Bryan, J. (2006). Assessment Results Following Inquiry and Traditional Physics Laboratory Activities. *Journal of College Science Teaching*, 35(7), 56.
- Bryant, R. J., & Marek, E. A. (1987). They Like Lab-Centered Science. *Science Teacher*, 54(8), 42.

- Bybee, R. (2000). Teaching science as inquiry. In J. Minstrell & E. van Zee (Eds.), *Inquiring into inquiry learning and teaching in science*. Washington, D.C.: American Association for the Advancement of Science.
- Caldwell, O.W. (1924). American association for the advancement of science committee on the place of the sciences in education. *American Association for the Advancement of Science*, 60 (1563), 531-550.
- Carr, W. and Kemmis, S. (1986) *Becoming critical: education knowledge and Action Research*. London: Falmer Press.
- Campbell, J. (2008). The value of student ratings: Perceptions of students, teachers, and administrators. *Community College Journal of Research and Practice*, 32(1), 13-24.
- Chi, M., Feltovich, P., and Glaser, R. (1981). Categorization and representation of physics problems by experts and novices. *Cognitive Science*, 5, 121-152.
- Chiappetta, E. L. (2008). Historical development of teaching science as inquiry. In Luft, J., Bell, R. L., & Gess-Newsome, J. (Eds.), *Science as Inquiry in the Secondary Setting* (pp. 21-30). Arlington, VA: NSTA Press.
- Christophel, D., & Gorham, J. (1995). A test/retest analysis of student motivation, teacher immediacy, and perceived sources of motivation and demotivation in college classes. *Communication Education*, 44, 292/306.
- Classrooms as Laboratories: The Science of Learning Meets the Practice of Teaching. Hearing Before the Subcommittee on Research, Committee on Science, House of Representatives, 107th Congress, First Session, (2001).
- Cockman, John. "Cookbook vs. Inquiry." 6 August 2008. Online posting. TAP-L Discussion Group. <[lists.nesu.edu/cgi-bin/digest?list=tap-l](http://lists.nesu.edu/cgi-bin/digest?list=tap-l)>

- Coffey, A. (1999). *The Ethnographic Self: Fieldwork and the representation of identity*. London: Sage.
- Cohen, S. M. (2005). Active learning in lectures introducing magnetic induction. *American Journal of Physics*, 73(3), 284-285.
- Collette, A. T. & Chiappetta, E. L. (1989). *Science instruction in the middle and secondary school*. Merrill Publishing Company, 2<sup>nd</sup> Edition, London.
- Corey, S.M. (1953). *Action Research to improve school practices*. New York: Teachers College Press.
- Cox, A., & Junkin, W. (2002). Enhanced Student Learning in the Introductory Physics Laboratory. *Physics Education*, 37(1), 37-44.
- Crouch, C., Watkins, J., Fagen, A., & Mazur, E. (2007). Peer instruction: Engaging students one-on-one, all at once. *Research -Based Reform of University Physics*, 60, 1-55.
- Dancy, M., 2000. Investigating animations for assessment with an animated version of the Force Concept Inventory *Dissertation* North Carolina State University, online at <http://webphysics.davidson.edu/faculty/mhd/dissertation/> accessed on 2 June 2001
- DeBoer, G. E. 1991. *A History of Ideas in Science Education*. New York: Teachers College, Columbia University.
- DeBoer, G. E. (2000). Scientific literacy: Another look at its historical and contemporary meanings and its relationship to science education reform. *Journal of Research in Science Teaching*, 37, 582-601.
- Demchik, M., & Demchik, V. (1970). How Inquiry May Set the Structure for Learning. *54(1)*, 1-3.

- Demirci, N. (2000). Students' attitudes toward introductory physics course. . *Hacettepe Üniversitesi Eğitim Fakültesi Dergisi*, 36 (33-40).
- Denzin, N., & Lincoln, Y. Eds.). (1998). *The landscape of qualitative research: Theories and issues*. Thousand Oaks: Sage Publications.
- Derry, S. J., Hickey, D., & Koschmann, T. (2007). Ethical concerns in video data collection. In S.J. Derry (Ed.), *Guidelines for video research in education: Recommendations from an expert panel*. Chicago: Data Research and Development Centre at the University of Chicago
- Dewey, J. (1916). *Democracy and Education*. New York: Macmillan.
- Dewey, J. (1938). *Experience and Education*. New York: Macmillan.
- Dewey, J. (1974). *John Dewey on Education*. Chicago: University of Chicago Press.
- Domin, D.S. (1999). A review of laboratory instruction styles. *Journal of Chemical Education*, 76 (4), 543-547.
- Driver, R. & Easley, J. (1978). Pupils and paradigms: a review of literature related to concept development in adolescent science students. *Studies in Science Education*, 5, 61-84.
- Driver, R., & Oldham, V. (1986). A constructivist approach to curriculum development. *Studies in Science Education*, 13, 105-122.
- Educational Broadcasting Corporation (2004). *Concept to Classroom* [Electronic version]. Retrieved on June 25, 2008 from [http://www.thirteen.org/edonline/concept2class/constructivism/index\\_sub4.html](http://www.thirteen.org/edonline/concept2class/constructivism/index_sub4.html)
- Elby, A. (2001a). Epistemological Beliefs Assessment for Physical Science <http://www2.physics.umd.edu/~elby/EBAPS/home.htm>

- Elby, A. (2001b) Helping physics students learn how to learn. *American Journal of Physics*, 69(7), s54-s64.
- Eltinge, E. M. & Roberts, C. W. (1993). Linguistic content analysis: A method to measure science as inquiry in textbooks. *Journal of Research in Science Teaching*, 30(1), 65-83.
- Etkina, E., Murthy, S. and Zou, X. (2006). Using introductory labs to engage students in experimental design, *American Journal of Physics*, 74, 979 (2006).
- Fairclough, P. (Executive Producer). (2003). *Mythbusters* [Television Series]. Silver Spring, MD: Discovery Channel
- Feldman, A. (1994). *Teachers Learning from Teachers: Knowledge and Understanding in Collaborative Action Research*. Paper presented at the Annual Meeting of the American Educational Research Association. from <http://search.ebscohost.com/login.aspx?direct=true&db=eric&AN=ED369756&site=ehost-live>
- Feldman, A. (1996). Enhancing the practice of physics teachers: Mechanisms for the generation and sharing of knowledge and understanding in collaborative action research. *Journal of Research in Science Teaching*, 33(5), 513-540.
- Feldman, A., & Minstrell, J. (2000). Action research as a research methodology for the study of the teaching and learning of science. In E. Kelly & R. Lesh (Eds.), "Handbook of research design in mathematics and science education." Mahwah, NJ: Lawrence Erlbaum Associates.
- Ferrance, E. (2000) *Action Research*. Providence, RI: Northeast and Islands Regional Educational Laboratory.

- Freire, P. (1993). *Pedagogy of the oppressed*. New York: Continuum.
- Gabbard, R., Kaiser, A., & Kaunelis, D. (2007). Redesigning a Library Space for Collaborative Learning. *Computers in Libraries*, 27(5), 6-11.
- Gabel, D. (1995). "NARST Presidential Address." California, National Association for Research in Science Teaching [Conference]. San Francisco. 24 Apr. 1995.
- Gagne, R. M. and Gephart, W. J. (Eds.), (1968). *Learning Research and School Subjects*. Itasca, Illinois: F.E. Peacock, p. 107-133.
- Gagne, R. M. & White, R. T. (1978). Memory structures and learning outcomes. *Review of Educational Research*, 48(2), 187-222.
- Gang, S. (1995). Removing Preconceptions with a "Learning Cycle." *Physics Teacher*, 33(6), 346.
- Gardner, D. P. (1983). *A Nation at Risk: The Imperative for Education Reform. An Open Letter to the American People. A Report to the Nation and the Secretary of Education*.
- Geelan, D., Wildy, H., Loudon, W., & Wallace, J. (2004). Teaching for Understanding and/or Teaching for the Examination in High School Physics. Research Report. *International Journal of Science Education*, 26(4), 447-462.
- GET (2007) General Education Taskforce at Appalachian State University, April 12, 2007. Forum Theme Design Guidelines: Science Inquiry Perspective.
- Glagovich, N., & Swierczynski, A. (2004). Teaching failure in the laboratory: turning mistakes into learning opportunities. *Journal of College Science Teaching* 33(6), 45-47.



- Glesne, C., & Peshkin, P. (1992). *Becoming qualitative researches: An introduction*. New York, NY: Longman.
- Good, T., & Brophy, J. (2003). *Looking in classrooms* (9th ed.). Boston: Pearson Education.
- Goodson, I. (1993). The Devil's Bargain: Educational Research and the Teacher . *Education Policy Analysis Archives, 1*, 3. Retrieved from <http://epaa.asu.edu/ojs/article/view/680>.
- Hake, R. (1987) Promoting student crossover to the Newtonian world. *American Journal of Physics, 55*, 878.
- Hake, R., Tobias, S. (1988). Professors as physics students: What can they teach us? *American Journal of Physics, 56*, 786.
- Hake, R. (1992). Socratic Pedagogy in the Introductory Physics Laboratory. *Physics Teacher, 30*(9), 546-552.
- Hake, R. (1998). Interactive-engagement vs traditional methods: A six-thousand-student survey of mechanics test data for introductory physics courses, *American. Journal of Physics, 66*, 64- 74 (1998).
- Hake, R. (2004). *The Arons-Advocated Method* [Electronic Version]. Retrieved on July 8, 2008 from <http://physics.indiana.edu/~hake/AronsAdvMeth-8.pdf>
- Hakkarainen, K. (2004). Pursuit of Explanation within a Computer-Supported Classroom. *International Journal of Science Education, 26*(8), 979-996.
- Halloun I, (1997). Views About Science and Physics Achievement: The VASS Story. In *The Changing Role of Physics Departments in Modern Universities: Proceedings of the ICUPE*.

- Halloun, I. & Hestenes, D. (1985). The initial knowledge state of college physics students. *American Journal of Physics*, 53(11), 1043-1055.
- Hammer, D. (1999). *Teacher Inquiry. Center for the Development of Teaching Paper Series*.  
Newton, MA: Education Development Center for the Development of Teaching.
- Hammer, D. (1996). More than misconceptions: multiple perspectives on student knowledge and reasoning, and an appropriate role for education research. *American Journal of Physics*, 64, 1316-1325.
- Harrington, R. (1997). New Standards for Teaching Middle School Science: Now That We Have Them, What Do We Do? *Journal of Research in Rural Education*, 13(1), 37-46.
- Heller, P., Keith, R. & Anderson, S. (1992). Teaching problem solving through cooperative grouping. Part 1: Group versus individual problem solving. *American Journal of Physics*, 60(7), 627-636.
- Herron, M. D. (1971). The nature of scientific enquiry. *The School Review*, 79(2), 171-212.
- Hestenes, D. (1987). Toward a modeling theory of physics instruction. *American Journal of Physics*, 55(5), 440-454.
- Hestenes, D., Wells, M. & Swackhamer, G. (1992). Force concept inventory. *The Physics Teacher*, 30, 141-151.
- Hestenes, D., Halloun, I. (1995). Interpreting the Force Concept Inventory. *The Physics Teacher*, 33(8), 504, 507-511.
- Hopkins, D. (1985). A teacher's guide to classroom research. Philadelphia: Open University Press.

- Horton, R., & Leonard, W. (2005). Mathematical Modeling in Science: Using Spreadsheets to Create Mathematical Models and Address Scientific Inquiry. *Science Teacher*, 72(5), 40-45.
- Houlden, M., & et al. (1983). A 'Phenomena Laboratory' for Physics Students. *Physics Education*, 18(3), 125-127.
- Huffman D and Heller P 1995 What does the Force Concept Inventory actually measure? *Physics Teacher* 33, 138-43.
- Jackson, J., Dukerich, H., Hestenes, D., (2008). Modeling instruction: An effective model for science education. *Science Educator*, 17(1), 10-17.
- Johnson, B., Sullivan, A., & Williams, D. (2009). A One-Eyed Look at Classroom Life: Using New Technologies to Enrich Classroom-Based Research. *Issues in Educational Research*, 19(1), 34-47.
- Kalman, C. (2002). Developing Critical Thinking in Undergraduate Courses: A Philosophical Approach. *Science and Education*, 11(1), 83-94.
- Kanter, D., Smith, H., McKenna, A., Rieger, C., & Linsenmeier, R. (2003). *Inquiry-based Laboratory Instruction Throws Out the "Cookbook" and Improves Learning*. Paper presented at the American Society for Engineering Education Annual Conference & Exposition.
- Kearney, M. (2004). Classroom Use of Multimedia-Supported Predict--Observe--Explain Tasks in a Social Constructivist Learning Environment. *Research in Science Education*, 34(4), 427-453.
- Kelsay, K.L. (1991, Spring). When experience is the best teacher: The teacher as researcher. *Action in Teacher Education*, 13(1), 14-21.

- Kemmis, S., and McTaggart, R., eds. (1988) *The Action Research planner*, third edition. Victoria: Deakin University.
- Khoon, K., & Othman, M. (2004). Some Thoughts on the Introductory Course in Physics. *College Student Journal*, 38(4), 503-509.
- Kolodiy, G.O. (1977). Cognitive development and science teaching. *Journal of Research in Science Teaching*, 14 (1), 21-26.
- Kubli, F. (2001). Galileo's 'Jumping-Hill' Experiment in the Classroom--A Constructivist's Analysis. *Science and Education*, 10(1-2), 145-148.
- Kuntz, R. (1998). *Lessons Learned: Formal Computer Laboratory Exercises*. Paper presented at the Association of Small Computer Users in Education Conference. from <http://search.ebscohost.com/login.aspx?direct=true&db=eric&AN=ED425720&site=ehost-live>
- Laws, P. (1989). *Workshop Physics. FIPSE Final Report*: Dickinson College, Carlisle, PA Tufts University, Medford, MA.
- Laws, P. (1991a). Calculus-based physics without lectures. *Physics Today*, 44(12), 24-31.
- Laws, P. (1991b). Workshop Physics: Learning Introductory Physics by Doing It. *Change*, 23(4), 20.
- Laws, P. (1997). Millikan Lecture 1996: Promoting active learning based on physics education research in introductory physics courses. *American Journal of Physics*, 65(1), 14-21.
- Laws, P. (1999). New Approaches to Science and Mathematics Teaching at Liberal Arts Colleges. *Daedalus*, 128(1), 217-240.
- Laws, P. (2004a). *Workshop Physics*: Wiley.

- Laws, P. (2004b). *Workshop Physics Overview*. Retrieved February 19, 2008, from Dickinson College's Physics and Astronomy Web site:  
[http://physics.dickinson.edu/~wp\\_web/wp\\_overview.html](http://physics.dickinson.edu/~wp_web/wp_overview.html)
- Laws, P., Roseborough, P., & Poodry, F. (1995). Women's Responses to an Activity-Based Introductory Physics Program. *New Directions for Teaching and Learning*(61), 77-87.
- Laws, P., & Thornton, R. (1993). *FIPSE Interactive Physics Project (October 1989-August 1993). Final Report*. Carlisle, PA: Dickinson College.
- Leonard, W., & Gerace, W. (1999). *A Demonstration of Kinematics Principles*: Massachusetts University, Amherst. Physics Education Research Group.
- Leonard, W., Gerace, W., Dufresne, R., & Mestre, J. (1999a). *Concept-Based Problem Solving: Combining Educational Research Results and Practical Experience To Create a Framework for Learning Physics and To Derive Effective Classroom Practices*: Massachusetts University, Amherst. Physics Education Research Group.
- Leonard, W., Dufresne, R., Gerace, W. & Mestre, J. (1999b). *Minds-on Physics: Interactions*. Iowa City, IA: Kendall/Hunt.
- Likert, R. (1932). *A technique for the measurement of attitudes*. New York: Archives of Psychology.
- Lincoln, Y., & Guba, E. (1985). *Naturalistic inquiry*. Beverly Hills, CA: Sage.
- Liu, X. (2006). Student Competence in Understanding the Matter Concept and Its Implications for Science Curriculum Standards. *School Science and Mathematics*, 106(5), 220-227.

- Mahajan, S. (1999). *Observations on Teaching First-year Physics* a report to the Cavendish teaching committee, Cambridge University, online at <http://wol.ra.phy.cam.ac.uk/sanjoy/teaching/tc-report/> accessed on 2 June 2001
- MacIsaac, D. (1996). *An introduction to Action Research*. Retrieved March 25, 2010 from <http://physicsed.buffalostate.edu/danowner/actionrsch.html>.
- MacIsaac, D. & Falconer, K. (2002). Reforming physics education via RTOP. *The Physics Teacher*, 40(8), 479-485.
- Marshall, J., & Dorward, J. (1997). Revisiting Inquiry and Prescriptive Laboratory Experiences in Introductory Physics. *American Journal of Physics*, .
- Marshall, J. A., & Dorward, J. T. (2000). Inquiry Experiences as a Lecture Supplement for Preservice Elementary Teachers and General Education Students. *American Journal of Physics*, 68(7), S27-S36.
- Mazur, E. (1997). *Peer Instruction*. Englewood Cliffs, NJ: Prentice-Hall.
- McBride, J., Bhatti, M., Hannan, M., & Feinberg, M. (2004). Using an Inquiry Approach to Teach Science to Secondary School Science Teachers. *Physics Education*, 39(5), 434-439.
- McDermott, L. C. (1996). *Physics by Inquiry*. John Wiley & Sons, 1996.
- McDermott, L. C. & Redish, E. F. (1999). Resource Letter: PER-1: Physics Education Research. *American Journal of Physics*, 67(9), 755-767.
- McDermott, L. C., & Shaffer, P. S. (1992). Research as a guide for curriculum development: An example from introductory electricity Part I: Investigation of student understanding. *American Journal of Physics*, 60(11), 994-1003.

- McInnis, C., James, R., Beattie, K., McNaught, C., Simmons, C., & Ferber, S. (1995). *Enhancing the First Year Experience* (No. 0-7325-1319-7): Melbourne University, Centre for the Study of Higher Education, Australia.
- Meltzer, D., & Manivannan, K. (2002). Transforming the Lecture Hall Environment: The Fully Interactive Physics Lecture. *American Journal of Physics*, 70(6), 639-654.
- McKittrick, B., Mulhall, P. & Gunstone, R. (1999). Improving understanding in physics: An effective teaching procedure. *Australian Science Teachers' Journal*, 45(3), 1-10.
- Milner-Bolotin, M. (2004). Tips for using a peer response system in a large introductory physics class. *The Physics Teacher*, 42(4), 253-254.
- National Education Association (1894). *Report of the Committee of Ten on Secondary School Studies: With the Reports of the Conferences Arranged by the Committee*. American Book Company.
- National Research Council (1996). *National science education standards*. Washington DC: National Academy Press.
- National Research Council. (2000). *Inquiry in School Science: Historical Perspective*. Washington, D.C.: National Academy Press.
- National Science Foundation. (1993). *The Role of Faculty from the Scientific Disciplines in the Undergraduate Education of Future Science and Mathematics Teachers*. Retrieved from <http://search.ebscohost.com/login.aspx?direct=true&db=eric&AN=ED380284&site=ehost-live>

- Neumann, H. (1917). *Moral Values in Secondary Education: A Report of the Commission on the Reorganization of Secondary Education, Appointed by the National Education Association*. Washington Government Printing Offices.
- Nissani, M., & et al. (1994). A Guided Discovery Exercise for Introductory Physics Labs. *Physics Teacher*, 32(2), 104-107.
- Novak, G., Patterson, E., Gavrin, A. & Christian, W. (1999). *Just-in-Time Teaching: Blending Active Learning with Web Technology*. Prentice Hall: Upper Saddle River, NJ.
- O'Kuma, T. L., Maloney, D. P. & Hieggelke, C. J. (2000). *Ranking Task Exercises in Physics*. Upper Saddle River, NJ: Prentice Hall.
- Pandey, J. Srinivasan, J., and Gupta, A. (Eds.). (2008). *Advances in Cognitive Science, Vol. 1*. Thousand Oaks, CA: Sage Publications.
- Patton, M. (2002). *Qualitative research and evaluation methods*. Thousand Oaks, CA: Sage.
- Pavelich, M. J., & Abraham, M. R. (1977). Guided inquiry laboratories for general chemistry students. *Journal of College Science Teaching*, 7(1), 23-26.
- Piaget, J. (1983). *Piaget's theory*. In P. Mussen (ed.). *Handbook of Child Psychology*. 4th edition. Vol. 1. New York: Wiley.
- Qin, Z., & Johnson, D. (1995). Cooperative Versus Competitive Efforts and Problem Solving. *Review of Educational Research*, 6(2), 129-143.
- Ramsden, J. M. (1998). Mission impossible: can anything be done about attitudes to science? *International Journal of Science Education*, 20(2), 125-137.
- RCOE (2010). Conceptual Framework, taken from <http://www.ced.appstate.edu/about/conceptualframework/>.



- Redish, E., & Risley, J. (1990). *Computers in Physics Instruction. Proceedings of a Conference (Raleigh, North Carolina, August 1-5, 1988)*.
- Redish, E. F., Steinberg, R. N. & Saul, J. M. (1998). Student expectations in introductory physics. *American Journal of Physics*, 66, 212-224.
- Redish, E. (1999). *Diagnosing Student Problems Using the Results and Methods of Physics Education Research*. Giulini, China: International Conference on Physics Teaching.
- Redish, E., & Steinberg, R. (1999). *Teaching Physics: Figuring Out What Works*.
- Redish, E., Saul, J., & Steinberg, R. (2000). *On the Effectiveness of Active-Engagement Microcomputer-Based Laboratories*.
- Redish, E. (2000). *New Models of Physics Instruction Based on Physics Education Research*. Paper presented at the Deutschen Physikalischen Gesellschaft from <http://search.ebscohost.com/login.aspx?direct=true&db=eric&AN=ED438184&site=ehost-live>
- Redish, E.F. (2003). *Teaching Physics with Physics Suite*. New York: John Wiley.
- Redish, E. (2004). *A Theoretical Framework for Physics Education Research: Modeling Student Thinking*. Varenna, Italy: International School of Physics.
- Reich College of Education. (2010). Conceptual Framework, Retrieved March 16, 2010 from [www.ced.appstate.edu/about/conceptualframework/](http://www.ced.appstate.edu/about/conceptualframework/).
- Reid, N., & Skryabina, E. A. (2002). Attitudes towards physics. *Research in Science and Technological Education*, 20(1), 67-81.

- Reiff, R. (2002). *If Inquiry Is So Great, Why Isn't Everyone Doing It?* Paper presented at the Proceedings of the Annual International Conference of the Association for the Education of Teachers in Science. from <http://search.ebscohost.com/login.aspx?direct=true&db=eric&AN=ED465642&site=ehost-live>
- Renner, J., & et al. (1985). Secondary School Students' Beliefs about the Physics Laboratory. *Science Education*, 69(5), 649-663.
- Rhea, M., Lucido, P., & Gregerson-Malm, C. (2005). Using Process and Inquiry to Teach Content: Projectile Motion and Graphing. *Science Activities: Classroom Projects and Curriculum Ideas*, 42(3), 10-15.
- Richards, L. (2005). *Handling qualitative data: A practical guide*. London: Sage Publications.
- Richardson, V. & Renner, J.W. (1970). A study of the inquiry-discovery method of laboratory instruction. *Journal of Chemical Education*, 47, 77-79.
- Robinson, S. (1995). *Student Stories in a High School Physics Class*. Paper presented at the Annual Meeting of the Southeastern Association for the Education of Teachers in Science. from <http://search.ebscohost.com/login.aspx?direct=true&db=eric&AN=ED417086&site=ehost-live>
- Roth, W. (1990). *Collaboration and Constructivism in the Science Classroom*. Paper presented at the Annual Meeting of the American Educational Research Association. from <http://search.ebscohost.com/login.aspx?direct=true&db=eric&AN=ED318631&site=ehost-live>
- Roth, W. (1994). Experimenting in a Constructivist High School Physics Laboratory. *Journal of Research in Science Teaching*, 31(2), 197-223.

- Royuk, B. (2002). Interactive-engagement versus cookbook laboratory procedures in MBL mechanics exercises. Unpublished Dissertation, University of Nebraska, Lincoln, NE.
- Royuk, B., & Brooks, D. (2003). Cookbook Procedures in MBL Physics Exercises. *Journal of Science Education and Technology*, 12(3), 317-324.
- Russell, D., Lucas, K., & McRobbie, C. (1999). *Microprocessor Based Laboratory Activities as Catalysts for Student Construction of Understanding in Physics*. Paper presented at the Annual Meeting of the Australian Association for Research in Education and New Zealand Association for Research in Education. from <http://search.ebscohost.com/login.aspx?direct=true&db=eric&AN=ED453067&site=ehost-live>
- Sadaghiani, H. (2008). Physics by inquiry: Addressing student learning and attitude. *Proceedings of the Physics Education Research Conference, Canada, 1064*, 191-194.
- Saul, J., Deardorff, D., Abbott, D., Allain, R., & Beichner, R. (2000). *Evaluating Introductory Physics Classes in Light of the ABET Criteria: An Example from the SCALE-UP Project*: American Society of Engineering Education.
- Schmidt, W. H., McKnight, C. C., & Raizen, S. A. (1997). *A splintered vision: An investigation of U.S. science and mathematics education*. Boston: Kluwer Academic Publications.
- Schneider, R., & Krajcik, J. (1999). *The Role of Educative Curriculum Materials in Reforming Science Education*. Arlington, VA: National Science Foundation.
- Schneider, R., Krajcik, J., & Blumenfeld, P. (2005). Enacting Reform-Based Science Materials: The Range of Teacher Enactments in Reform Classrooms. *Journal of Research in Science Teaching*, 42(3), 283-312.
- Schwab, J. (1960). What do scientists do? *Behavioral Science*, 5(1).

- Schwab, J. (1962). *The teaching of science as enquiry*. In J.J.Schwab & P.F. Brandwein (Eds.). Cambridge: Harvard University Press.
- Sharma, M. (1999). Workshop tutorials: accommodating student-centered learning in large first year university physics courses. *International Journal of Science Education*, 21(8), 839-853.
- Sokoloff, D. R. & Thornton, R. K. (1997). Using interactive lecture demonstrations to create an active learning environment. *The Physics Teacher*, 35, 340-347.
- Sokoloff, D., Thornton, R., & Laws, P. (2004). *RealTime Physics*: Wiley.
- Staten, M. E. (1998). "Action research study: A framework to help move teachers toward an inquiry-based science teaching approach." Milwaukee, WI: Milwaukee Public Schools.
- Stinner, A. (2006). The Large Context Problem (LCP) Approach. *Interchange: A Quarterly Review of Education*, 37(1-2), 19-30.
- Stokking, K. (2000). Predicting The Choice of physics in secondary Education. *International Journal of Science Education*, 22(12), 1261-1283.
- Sunal, D. W., Hodges, J., Sunal, C. S., Whitaker, K. W., Freeman, L. M., Edwards, L., et al. (2001). Teaching science in higher education: faculty professional development and barriers to change. *School Science and Mathematics*, 101(5), 246-258.
- Syh-Jong, J. (2007). A Study of Students' Construction of Science Knowledge: Talk and Writing in a Collaborative Group. *Educational Research*, 49(1), 65-81.
- Tamir P., (1977). How are the laboratories used? *Journal of Research in Science Teaching*, 14, 311-316.

- Thacker, B., Kim, E., Trefz, K., & Lea, S. (1994). Comparing Problem Solving Performance of Physics Students in Inquiry-Based and Traditional Introductory Physics Courses. *American Journal of Physics*, 62(7), 627-633.
- Thornton, R. K. (1987). Tools for scientific thinking - microcomputer-based laboratories for physics teaching. *Physics Education*. 22(4), 230-238.
- Thornton, R., & Sokoloff, D. (1990). Learning motion concepts using real-time microcomputer-based laboratory tools. *American Journal of Physics*, 58(9), 858-867.
- Thornton, R. K. & Sokoloff, D. R. (1996). *RealTime Physics: Active learning laboratory*, in *The Changing Role of Physics Departments in Modern Universities*, E. F. Redish and J. S. Rigden, eds., AIP Conf. Prof. 399, 1101-1118.
- Trumper, R. (2002). What Do We Expect From Students' Physics Laboratory Experiments? *Journal of Science Education and Technology*, 11(3), 221-228.
- Uretsky, J. (1993). Using "Dialogue" Labs in a Community-College Physics Course. *Physics Teacher*, 31(8ov), 478-481.
- Van Heuvelen, A. (1991). Learning to Think Like a Physicist: A Review of Research-Based Instructional Strategies. *American Journal of Physics*, 59(10), 891-897.
- van Zee, E., Hammer, D., Bell, M., Roy, P., & Peter, J. (2005). Learning and Teaching Science as Inquiry: A Case Study of Elementary School Teachers' Investigations of Light. *Science Teacher Education*, 89(6ov), 1007-1042.
- Viennot, L., Chauvet, F., Colin, P., & Rebmann, G. (2005). Designing Strategies and tools for teacher training: The role of critical details, examples in Optics. *Science Education*, 89(13-27).

- Volkman, M., & Zgagacz, M. (2004). Learning to Teach Physics through Inquiry: The Lived Experience of a Graduate Teaching Assistant. *Journal of Research in Science Teaching*, 41(6), 584-602.
- Watson, J., Swain, J., & McRobbie, C. (2004). Students' Discussions in Practical Scientific Inquiries. Research Report. *International Journal of Science Education*, 26(1), 25-45.
- Wells, M., Hestenes, D., Swackhamer, G. (1995). A modeling method for high school instruction. *American Journal of Physics*, 63(7), 1-34.
- Wenning, C., & Wenning, R. (2006). A generic model for inquiry-oriented labs in postsecondary introductory physics. *Journal of Physics Teacher Education Online*, 3(3), 24-33.
- White, R. (1978 July). *Relevance of Practical Work to Comprehension of Physics*. Paper presented at the Conference on "The Role of the Laboratory in Physics Education", Oxford University.
- Wilson, J. M. & Redish, E. F. (1992). The comprehensive unified physics learning environment: Part I. Background and system operation. *Computers in Physics*, 6, 202-209 (March/April 1992); The comprehensive unified physics learning environment: Part II. The basis for integrated studies, *ibid.*, 282-286 (May/June 1992).
- Woolnough, B. E. (1994). Why students choose physics, or reject it. . *Physics Education*, 29, 368-374.
- Zuiker, A. (Creator). (2000). *CSI* [Television Series]. New York: CBS



## WORKS CONSULTED

- Alessi, S. M., & Pena, C. M. (1999). Promoting a Qualitative Understanding of Physics. *Journal of Computers in Mathematics and Science Teaching*, 18(4), 439.
- Anslow, J. (1999). Just What is Exciting Physics? *Physics Education*, 34(6ov), 389.
- Blanton, P. (2007). Developing an Inquiry Lesson. *The Physics Teacher*, 45, 56-57.
- Boller, B. R. (1999). *Non-Traditional Teaching Styles in Physics*. Presented in Issues of Education at Community Colleges: Essays by Fellows in the Mid-Career Fellowship Program at Princeton University.
- Bransford, J., Brown, A., & Cocking, R. (2000). How People Learn: Brain, Mind, Experience, and School: Expanded Edition. Washington, D.C.: National Academy Press.
- Cottam, M. (2006). Waves on the Fly--Encouraging Inquiry in the Physics Classroom. *Science Scope*, 29(4), 22.
- Crouch, C. & Mazur, E. (2001). Peer instruction: ten years of experience and results. *American Journal of Physics*, 69, 970.
- Discenna, J., & Howse, M. (1998). *Biology and Physics Students' Beliefs about Science and Science Learning in Non-Traditional Classrooms*. Paper presented at the Annual Meeting of the American Educational Research Association. from <http://search.ebscohost.com/login.aspx?direct=true&db=eric&AN=ED418887&site=ehost-live>



- Duran, L., McArthur, J., & Van Hook, S. (2004). Undergraduate Students' Perceptions of an Inquiry-Based Physics Course. *Journal of Science Teacher Education*, 15(2), 155-171.
- Espinoza, F. (2005). An Analysis of the Historical Development of Ideas about Motion and Its Implications for Teaching. *Physics Education*, 40(2), 139-146.
- Falconer, K., Wyckoff, S., Joshua, M., & Sawada, D. (2001). *Effect of Reformed Courses in Physics and Physical Science on Student Conceptual Understanding*. Paper presented at the Annual Meeting of the American Educational Research Association. from <http://search.ebscohost.com/login.aspx?direct=true&db=eric&AN=ED452083&site=ehost-live>
- Fencl, H., & Scheel, K. (2005). Engaging Students: An Examination of the Effects of Teaching Strategies on Self-Efficacy and Course Climate in a Nonmajors Physics Course. *Journal of College Science Teaching*, 35(1).
- Fetherston, T. (1999). Students' Constructs about Energy and Constructivist Learning. *Research in Science Education*, 29(4), 515-525.
- Ford, C. (1999). Collaborative construction of task activity: Coordinating multiple resources in a high school physics lab. *Research on Language and Social Interaction*, 32(4) 369-408.
- Geddis, A. (1991). *What To Do about "Misconceptions"--A Paradigm Shift*. Paper presented at the Annual Meeting of the American Educational Research Association. from <http://search.ebscohost.com/login.aspx?direct=true&db=eric&AN=ED351186&site=ehost-live>

- Gil-Perez, D., & Carrascosa, J. (1990). What to Do about Science "Misconceptions." *Science Education*, 74(5), 531-540.
- Hammer, D. (1995). Student Inquiry in a Physics Class Discussion. *Cognition and Instruction*, 13(3), 401-403.
- Hammer, D. (2000). Student resources for learning introductory physics. *American Journal of Physics, Physics Education Research Supplement*, 68 (S1), S52-S59.
- Hellingman, C. (1998). Newton's third law revisited. *Physics Education*, 27, 112-115.
- Helm, H. (1980). Misconceptions in physics amongst South African Students. *Physics Education*, 15, 92-98.
- Hoellwarth, C., Moelter, M. J., & Knight, R. D. (2005). A direct comparison of conceptual learning and problem solving ability in traditional and studio style classrooms. *American Journal of Physics*, 73(5), 459-462.
- Hubbard, P., & Abell, S. (2005). Setting Sail or Missing the Boat: Comparing the Beliefs of Preservice Elementary Teachers With and Without an Inquiry-Based Physics Course. *Journal of Science Teacher Education*, 16(1), 5-25.
- Huffman, D. (2006). Reforming Pedagogy: Inservice Teacher Education and Instructional Reform. *Journal of Science Teacher Education*, 17(2), 121-136.
- Hughes, M. (2002). How I misunderstood Newton's third law. *The Physics Teacher*, 40(6), 381-382.
- Johansson, K. E., & Nilsson, C. (1999). Stockholm Science Laboratory for Schools: A Complement to the Traditional Education System. *Physics Education*, 34(6ov), 345.
- Johnson, A. (2000). *Sociophysics Norms in an Innovative Physics Learning Environment*. New Orleans: American Educational Research Association.

- Lazarowitz, R. (1976). Does Use of Curriculum Change Teachers' Attitudes Toward Inquiry? *Journal of Research in Science Teaching*, 13(6), 547-552.
- Lewis, M. (1988). *Science Education Programs That work. A Collection of Proven Exemplary Educational Programs and Practices in the National Diffusion Network*. Washington, D.C.: Office of Educational Research and Improvement, Washington D. C. National Diffusion Network.
- Lynch, P. P. (1995). Students alternative frameworks: towards a linguistic and cultural interpretation. *International Journal of Science Education*, 17(1), 107-118.
- MacKinnon, G. (2006). An enhanced studio physics model: Which technologies are productive? *Journal of Computers in Mathematics and Science Teaching*, 25(1), 29-40.
- Marsh, H. (2007). Do university teachers become more effective with experience? A multilevel growth model of students' evaluations of teaching over 13 years. *Journal of Educational Psychology*, 99(4), 775-790.
- McDermott, L., Shaffer, P., & Constantinou, C. (2000). Preparing Teachers To Teach Physics and Physical Science by Inquiry. *Physics Education*, 35(6ov), 411-416.
- McGervey, J., & Heckathorn, D. (1990). Retraining Teachers in Physics. *The Physics Teacher*, 28(4), 230-231.
- Noddings, N. (2008). All Our Students Thinking. *Educational Leadership*, 65(5), 8-13.
- Oliva, J. M. (2003). The structural coherence of students' conceptions in mechanics and conceptual change. *International Journal of Science Education*, 25(5), 539-561.
- Park, J., & Kim, I. (1998). Analysis of Students' Responses to Contradictory Results Obtained by Simple Observation or Controlling Variables. *Research in Science Education*, 28(3), 365-376.

- Pilburn, M., Swanda, D., Falconer, K., Turley, J., Benford, R., & Bloom, I. (2000). Reformed Teaching Observation Protocol (RTOP): Arizona Collaborative for Excellence in Preparation of Teachers (ACEPT) in support from NSF IN-003.
- Pugliese, A. C. (1973). The meaning of inquiry, discovery, and investigative approaches to science teaching. *Science Teacher*, 40(1), 24-27.
- Quattrone, J., & Courville, G. (1977). Flexibly Structured, Inquiry-Based, Physical Science Course for Education Students. *American Journal of Physics* 45(2), 154-157.
- Sneider, C., & Ohadi, M. (1998). Unraveling Students' Misconceptions about the Earth's Shape and Gravity. *Science Education*, 82(2), 265-284.
- Spears, J., & Zollman, D. (1977). The Influence of Structured Versus Unstructured Laboratory on Students' Understanding the Process of Science. 33-38.
- Sokoloff, D. R. & Thornton, R. K. (2001). *Interactive Lecture Demonstrations*. Wiley.
- Sokoloff, D., & Thornton, R. (2004). *Interactive Lecture Demonstrations: Active Learning in Introductory Physics*: Wiley.
- Springer, L., Stanne, M., & Donovan, S. (1999). Effects of Small Group Learning on Undergraduates in Science, Mathematics, Engineering, and Technology: A Meta-Analysis. *Review of Educational Research*, 69(1), 21-51.
- Thijs, G. (1992). Evaluation of an Introductory Course on "Force" Considering Students' Preconceptions. *Science Education*, 76(2), 155-174.
- Ward, R., & Bodner, G. (1993). How Lecture Can Undermine The Motivation of Our Students. *Journal of Chemistry Education*, 70(3), 198-199.

- White, R. T. & Tisher, R. P. (1986). *Handbook of Research on Teaching*, 3<sup>rd</sup> ed.; Wittrock, M, Ed.; Macmillan: New York, 1986; pp 874-905.
- Wright, D. (2006). Comparing groups in a before–after design: When t test and ANCOVA produce different results. *British Journal of Educational Psychology*, 76, 663–675.

## APPENDIX A

## Laboratory Report and Observation Grading Rubrics

## Physics Laboratory Report Rubric

	<b>Excellent (3)</b>	<b>Good (2)</b>	<b>Acceptable (1)</b>	<b>Unacceptable (0)</b>
<b>Title Page</b>	Name, section, date, title of experiment, lab partners (first and last names), legibly written.	All but one of the components is included.	A few components of the title page are missing.	No title page is included
<b>Hypothesis and Procedure</b>	The purpose of the lab is clearly written, with all of the independent and dependent variables identified and explained in the context of the experiment. The apparatus is included, with diagrams if needed. The procedure is a concise and brief series of steps with an explanation of how to control the variables included. It is NOT an exhaustive description containing minute detail.	The Purpose addresses the procedural aspects of the lab, but does not accurately summarize the theoretical foundation of the experiment. The purpose is not clearly defined, or is missing 1-2 variables with explanations in the lab.	Question is in improper format and/or unclear. Hypothesis is present but has no variables identified within it. Improper format and/or 3-5 errors or omissions. Procedure is unclear. Apparatus list is minimal.	Purpose is missing, or is only loosely related to the lab being performed. 5 or more errors or omissions or is not included, no list of materials used. Hypothesis is unrelated or cannot answer the question or is not included. Procedure is missing altogether, or missing important steps, and is so confusing that a person could not replicate the experiment.
<b>Data</b>	Data are presented in a chart, table, or graph. All of the measurements are organized neatly with values and units clearly labeled. There are multiple trials taken as data. Correct units and precision are included, and the measuring device is indicated. Data are written in ink, and errant points are not obliterated. There are no calculations on the data page.	Similar to the excellent data page, except there may be one label missing, one omission of data, and minor misuse of precision or units.	Data is present but in wrong format, and/or major errors or omissions. Several labels are missing. Some of the tables need unit or precision corrections or are not clearly labeled. Data are obliterated. The results of calculations are on the data page.	The student has recorded data after completion of the lab. Some of the data and/or all labels are missing. The tables have no clear organization or units, and the number of trials is not sufficient to make an accurate conclusion. Data are obliterated. The results of calculations are on the data page.



	<b>Excellent (3)</b>	<b>Good (2)</b>	<b>Acceptable (1)</b>	<b>Unacceptable (0)</b>
<b>Calculations</b>	The student makes no more than 2 errors in labeling, calculations, units, and significant figures. Any diagrams are clearly drawn with all of the variables labeled. When needed, a table of calculated values is given with a sample calculation included. All calculations for one complete trial are clearly and correctly shown and the results labeled with the appropriate units and number of significant figures.	The student makes 3 to 5 errors in labeling, calculations, units, and significant figures. The diagram is not neat or is missing 1-2 labels. The procedure has 1-2 steps that may be unclear or ambiguous. Minor error and/or omissions.	Few of required calculations are shown. Calculations reflect major errors or omissions. Units are routinely omitted. Results are not clearly labeled and do not contain the correct number of significant figures. Diagrams are unclear and unhelpful.	The student makes more multiple errors in labeling, calculations, units, and significant figures or omits entire sets of calculations. Very little effort was put into the diagram, and the calculations show minimal effort.
<b>Graphs</b>	Graphs are clear and readable, titled and appropriately labeled with units and point protectors. Appropriate equations and functions are used to indicate trends, and connecting lines are avoided. Graphs are correctly interpreted; Information from the graphs is reasonable and useful. Graphs are printed full-page and landscape.	Similar to an excellent graph, with one or two omissions.	Graphs are not correctly titled or labeled. Units are missing. Points are unclear. Incorrect equations or functions are used.	Graphs are missing or incomplete. There are multiple errors. Graphs are not helpful and do not provide useful information.
<b>Error Analysis</b>	Sources of error are comprehensively considered. Student is able to discern which sources of error are most important. Error is sufficient to explain differences between data and calculations. Discussion is detailed and includes the relationship between trends/patterns seen, a thorough discussion of the data, and analysis of graphs. Any divergent results are given a reasonable explanation.	The report fails to meet one of the expectations for an excellent error analysis. Some minor errors are omitted.	Analysis is brief and there are major errors or omissions. Student has not thoughtfully considered all sources of error. Overall, section is not very thoroughly done.	Error analysis is missing, or demonstrates minimal effort.

	<b>Excellent (3)</b>	<b>Good (2)</b>	<b>Acceptable (1)</b>	<b>Unacceptable (0)</b>
<b>Conclusions</b>	The conclusion succinctly describes what can be concluded from the experimental results. It is aligned with a well-written statement of purpose at the beginning of the lab. Provides understanding of relevant scientific concepts. Includes both numerical and qualitative information. Addresses the results of the data analysis. Addresses all questions. Suggests thorough changes or improvements, poses new questions, and contains comments on significance of the experiment. Explains whether the data supports or rejects the hypothesis. The conclusion addresses the goals mentioned in the introduction.	Conclusion is present, and does not conflict with the student's experimental findings, but fails to address the theoretical basis for the lab. Discussion addresses hypothesis, and relates some but not all of the data to whether the data supports or rejects the hypothesis. The essential question is also answered correctly, with minor flaws.	Either the goals stated in the introduction are not completely addressed, or there is some confusion with how the variables affect the experiment. Efforts are made to explain divergent results. Conclusion has major errors or omissions. No meaningful conclusion can be drawn or the essential question is not answered.	Conclusion is missing, or is in conflict with the student's experimental results. No mention of the hypothesis, no discussion about the question relating to the data. The conclusion does not match up with the introduction and the majority of the variables are not explained. Demonstrates minimal effort.
<b>Overall Communication</b>	Lab is written with college-level vocabulary and format. Includes a title that is relevant to experiment. Each section is clearly labeled, neat, organized, and in the correct order. Rules of grammar, usage, and punctuation are followed; spelling is correct. Language is clear and precise; sentences display consistently strong, varied structure.	Lab is well written with minimal spelling or grammar errors which do not distract reader or impede communication. Minor errors and/or omissions.	One or more of the sections is out of place. Frequent errors in rules of grammar, spelling and punctuation. Language lacks clarity or includes the use of some jargon or conversational tone. Language distracts reader and impedes communication.	Several of the sections are out of place, with many errors in spelling and/or grammar. Language severely impedes communication. Demonstrates minimal effort.



## PHY1103-1104 Lab Observation Rubric

Section	Observed - Positive	Observed - Negative	Not applicable	Date =	Comments
<b>Time Management</b>					
Prepared for day's activities					
Staying on task					
<b>Demonstrating Experimental</b>					
Design skills					
Process skills					
<b>Respect for</b>					
Others					
Equipment					
<b>Communication with</b>					
Group					
Class					
Instructors					

## APPENDIX B

**Diagnostic Tool**

**Note:** The purpose of this Diagnostic Tool is to provide your instructor with information about your basic physics knowledge. This is NOT a test. Select the answer that best fits each question without spending too much time on each question.

**Instructions:** *Do not mark on this Tool. Use the answer sheet provided. On the answer sheet, include the following in pen or pencil: Name (Printed), Date, Course, and Course section or instructor. Your instructor may have you add information to the answer sheet, but it is not for identification purposes.*

1. Two metal balls are the same size, but one weighs twice as much as the other. The two balls roll off a horizontal table with the same speed. In this situation,
  - a) both balls hit the floor at approximately the same horizontal distance from the base of the table;
  - b) the heavier ball hits the floor at about half the horizontal distance from the base of the table than does the lighter ball;
  - c) the lighter ball hits the floor at about half the horizontal distance from the base of the table than does the heavier ball;
  - d) the heavier ball hits the floor considerably closer to the base of the table than the lighter ball, but not necessarily at half the horizontal distance;
  - e) the lighter ball hits the floor considerably closer to the base of the table than the heavier ball, but not necessarily at half the horizontal distance.
  
2. A stone dropped from the roof of a single-story building to the surface of the Earth
  - a) reaches maximum speed quite soon after release and then falls at a constant speed thereafter;
  - b) speeds up as it falls because the gravitational attraction gets considerably stronger as the stone gets closer to Earth;
  - c) speeds up because of an almost constant force of gravity acting upon it;
  - d) falls because of the natural tendency of all objects to rest on the surface of Earth;
  - e) falls because of the combined effects of the force of gravity pushing it downward and the force of the air pushing it downward.

3. A large truck collides head-on with a small compact car. During the collision
- the truck exerts a greater amount of force on the car than the car exerts on the truck;
  - the car exerts a greater amount of force on the truck than the truck exerts on the car;
  - neither exerts a force on the other, the car gets smashed simply because it gets in the way of the truck;
  - the truck exerts a force on the car, but the car does not exert a force on the truck;
  - the truck exerts the same amount of force on the car as the car exerts on the truck.

**Use the statement and figure below to answer Questions 4 through 6.**

The figure below depicts a hockey puck sliding with constant speed,  $v_o$ , in a straight line from point P to point Q on a frictionless, horizontal surface. Forces exerted by the air are negligible. You are looking down on the puck. When the puck reaches point Q, it receives a swift horizontal kick/hit in the direction of the heavy print arrow. Had the puck been at rest at point P, this kick would have set the puck in horizontal motion with speed,  $v_k$ , in the direction of the kick.

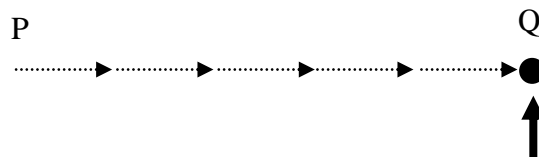

4. Which of the paths below would the puck most closely follow after receiving the kick/hit?

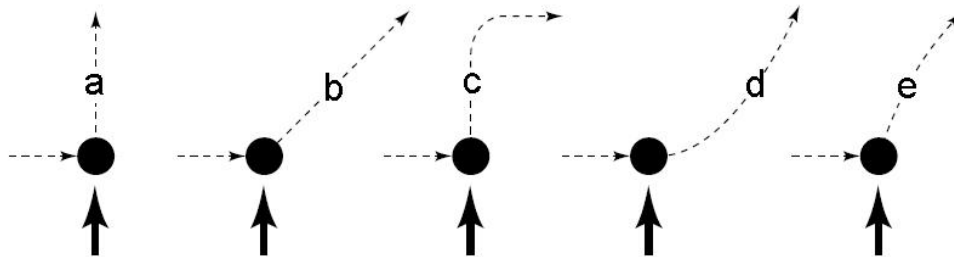

5. The speed of the puck just after it receives the kick/hit is
- equal to the speed  $v_o$  it had before it received the kick/hit;
  - equal to the speed  $v_k$  resulting from the kick and independent of the speed  $v_o$ ;
  - equal to the arithmetic sum of the speeds  $v_o$  and  $v_k$ ;
  - smaller than either of the speeds  $v_o$  or  $v_k$ ;
  - greater than either of the speeds  $v_o$  and  $v_k$ , but less than the arithmetic sum of these two speeds.

6. Along the frictionless path you have chosen in question 4, the speed of the puck after receiving the kick

- a) is constant; b) continuously increases; c) continuously decreases; d) increases for a while and decreases thereafter; e) is constant for a while and decreases thereafter.

7. A passenger's luggage accidentally falls from the cargo bay of an airplane as it flies in a horizontal direction. As observed by a person standing on the ground and viewing the plane (as depicted in the given figure), which of the paths would the luggage most closely follow after leaving the cargo bay of the plane?

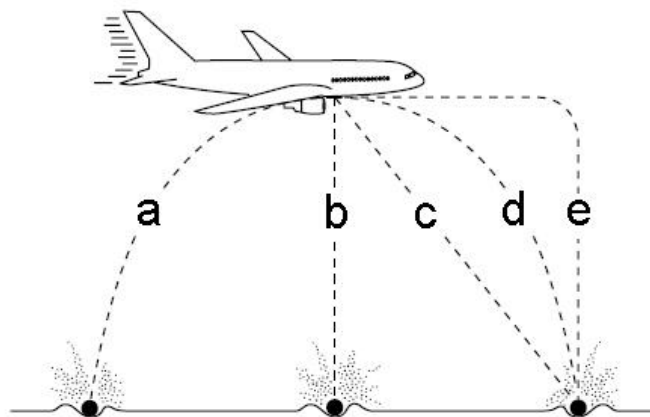

*Use the statement and figure below to answer Question 8 and 9.*

A large truck breaks down on the road and receives a push back into town from a small, compact car as shown in the given figure.

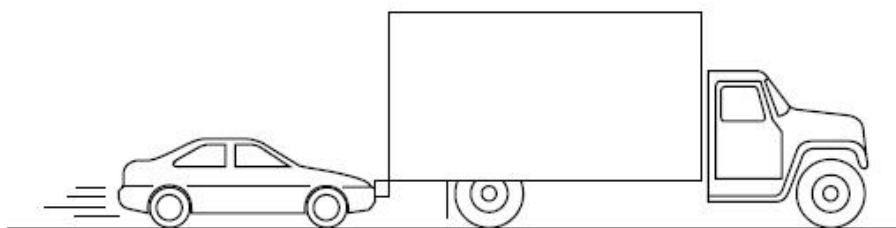

8. While the car, pushing the truck, is speeding up to get to cruising speed,

- a) the amount of force with which the car pushes on the truck is equal to that with which the truck pushes back on the car;  
 b) the amount of force with which the car pushes the truck is smaller than that with which the truck pushes back on the car;  
 c) the amount of force with which the car pushes the truck is greater than that with which the truck pushes back on the car;  
 d) the car's engine is running so the car pushes against the truck, but the truck's engine is not running so the truck cannot push back against the car. The truck is pushed forward simply because it is in the way of the car;  
 e) neither the car nor the truck exerts any force on the other. The truck is pushed forward simply because it is in the way of the car.

9. After the car reaches the constant cruising speed at which the driver wishes to push the truck,

- the amount of force with which the car pushes on the truck is equal to that with which the truck pushes back on the car;
- the amount of force with which the car pushes the truck is smaller than that with which the truck pushes back on the car;
- the amount of force with which the car pushes the truck is greater than that with which the truck pushes back on the car;
- the car's engine is running so the car pushes against the truck, but the truck's engine is not running so the truck cannot push back against the car. The truck is pushed forward simply because it is in the way of the car;
- neither the car nor the truck exerts any force on the other. The truck is pushed forward simply because it is in the way of the car.

10. An elevator is being lifted up an elevator shaft at a constant speed by a steel cable, as shown in the given figure. All frictional effects are negligible. In this situation, forces on the elevator are such that

- an upward force by the cable is greater than the downward force of gravity;
- the upward force by the cable is equal to the downward force of gravity;
- the upward force by the cable is smaller than the downward force of gravity;
- the upward force by the cable is greater than the sum of the downward force of gravity and the downward force due to air;
- none of the above. (The elevator goes up because the cable is being shortened, not because of an upward force is exerted on the elevator by the cable.)

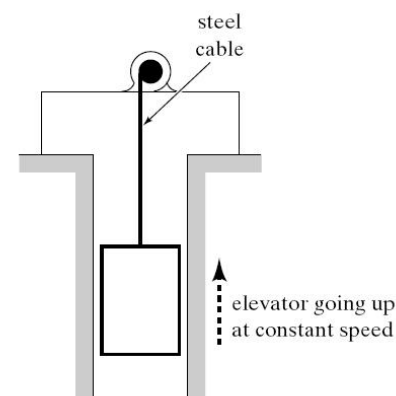

11. The positions of two blocks at successive 0.20 sec time intervals are represented by the numbered squares in the following figure. The blocks are moving to the right.

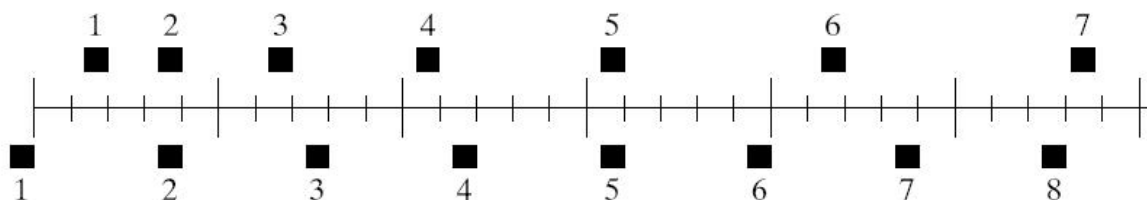

Do the blocks ever have the same speed?

- No;
- Yes, at instant 2;
- Yes, at instant 5;
- Yes, at instants 2 and 5;
- Yes, at some time during the interval 3 to 4.

12. The positions of two blocks at successive 0.20 sec time intervals are represented by the numbered squares in the following figure. The blocks are moving to the right.

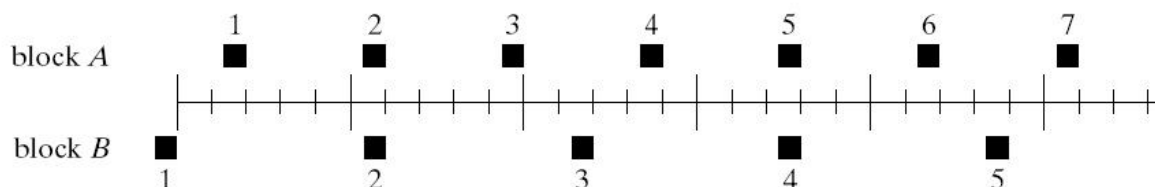

The accelerations of the blocks are related as follows:

- The acceleration of block A is greater than the acceleration of block B;
- The acceleration of A equals the acceleration of B. Both accelerations are greater than zero;
- The acceleration of B is greater than the acceleration of A;
- The acceleration of A equals the acceleration of B. Both accelerations are zero;
- Not enough information to answer the question.

*Use the statement and figure below to answer Question 13 through 15.*

A spaceship drifts sideways in outer space from point P to point Q, as shown in the given figure. The spaceship is subject to no outside forces. Starting at position Q, the spaceship's engine is turned on and produces a constant thrust (force on the spaceship) at right angles to the line PQ. The constant thrust is maintained until the spaceship reaches a point R in space.



13. Which of the paths below represents the path of the spaceship between points Q and R?

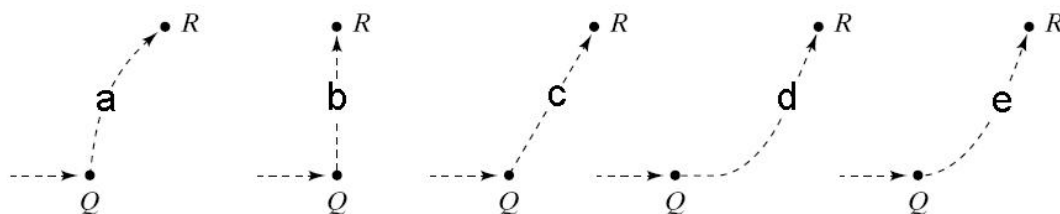

14. As the spaceship moves from point Q to point R, its speed is

- constant;
- continuously increasing;
- continuously decreasing;
- increasing for a while and constant thereafter;
- constant for a while and decreasing thereafter.

15. Beyond position R, the speed of the spaceship is

- constant;
- continuously increasing;
- continuously decreasing;
- increasing for a while and constant thereafter;
- constant for a while and decreasing thereafter.

16. A student exerts a constant horizontal force on a large box. As a result, the box moves across the horizontal floor at a constant speed,  $v_0$ . The constant horizontal force applied by the student

- a) has the same magnitude as the weight of the box;
- b) is greater than the weight of the box
- c) has the same magnitude as the total force that resists the motion of the box;
- d) is greater than the total force that resists the motion of the box;
- e) is greater than either the weight of the box or the total force that resists its motion.

17. If the student in Question 16 doubles the constant horizontal force that is exerted on the box in pushing it on the same horizontal floor, the box then moves

- a) with a constant speed that is double the speed  $v_0$  in the previous question;
- b) with a constant speed that is greater than the speed  $v_0$  in the previous question, but not necessarily twice as great;
- c) for a while with a speed that is constant and greater than the speed  $v_0$  in the previous question, then with a speed that increases thereafter;
- d) for a while with an increasing speed, then with a constant speed thereafter;
- e) with a continuously increasing speed.

18. If the student in Question 16 suddenly stops applying a horizontal force to the box, then the box

- a) immediately comes to a stop;
- b) continues to move at a constant speed for a while and then slows to a stop;
- c) immediately starts slowing to a stop;
- d) continues at constant speed;
- e) increases its speed for a while and then starts slowing to a stop.

19. In the following figure, student A has a mass of 75 kg and student B has a mass of 57 kg. They sit in identical office chairs facing each other. Student A places his feet on the knees of student B, as show. Student A then suddenly pushes outward with his feet, causing both chairs to move.

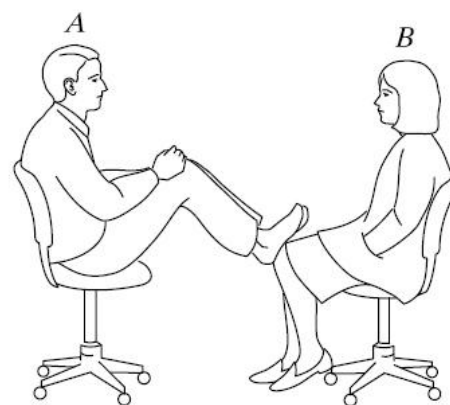

During the push, and while the students are still touching each other,

- a) neither student exerts a force on the other;
- b) student A exerts a force on student B, but B does not exert a force on A;
- c) each student exerts a force on the other, but B exerts the large force;
- d) each student exerts a force on the other, but A exerts the larger force;
- e) each student exerts the same amount of force on the other.

20. Despite a very strong wind, a tennis player manages to hit a tennis ball with a racquet so that the ball passes over the net and lands in the opponent's court. Consider the following forces:

1. a downward force of gravity;
2. a force by the "hit";
3. a force exerted by the air.

Which of the above force(s) is (are) acting on the tennis ball after it has left contact with the racquet and before it touches the ground?

- a) 1 only; b) 1 and 2; c) 1 and 3; d) 2 and 3; e) 1, 2, and 3.

21. A friend is riding on the back of a truck that is moving away from you at 20 mph. At the moment the truck has passed you, your friend throws a ball toward you at 60 mph, relative to her/him. How fast is the ball moving relative to you?

- a) 80 mph; b) 60 mph; c) 40 mph; d) 20 mph; e) 63 mph.

22. Why are doorknobs placed at the edge of the door rather than in the center?

- a) Because it's closer to the edge of the doorway; b) To help give more momentum to the door; c) To help give more energy to the door; d) To increase the force on the door; e) To increase the lever arm.

23. The source of all sound is

- a) a wave pattern; b) a harmonic object; c) a vibrating object; d) a variable high and low pressure region.

24. Smoke rises because

- a) the carbon particles are lighter than air; b) the gases in the smoke are warmer than the surrounding air; c) the gases contain hydrogen which is lighter than air; d) wind currents.

25. A piece of metal will feel colder than a piece of wood at the same temperature because

- a) metal is colder than wood; b) metals, in general, have a higher heat capacity than does wood; c) metals, in general, are good heat conductors; d) wood, in general, is a poor insulator; e) metal atoms are moving more slowly, on average, than wood atoms.



26. Three identical light bulbs (A, B, C) are connected in series to a battery, as shown. When the switch, S, is closed

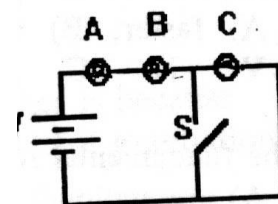

- a) all three remain as brightly lit as before;
- b) lights A and B are brightly lit and C is not lit at all;
- c) lights A and B are dimly lit and C is brightly lit;
- d) none of the bulbs are lit.

27. If the force of gravity suddenly stopped acting on the planets, they would

- a) continue to orbit the sun;
- b) fly straight away from the sun;
- c) move in a straight line tangent to their original orbit;
- d) spiral slowly away from the sun;
- e) spiral slowly towards the sun.

28. A magnetic field does **NOT** exert a force on

- a) a steel paper clip;
- b) a magnet;
- c) stationary charges;
- d) a moving charge;
- e) a current-carrying wire.

29. Electromagnetic waves are created by

- a) stationary charges;
- b) radio waves;
- c) accelerating charges;
- d) pressure variations;
- e) None of the above.

30. Which color of light contains the most energy?

- a) Red;
- b) Orange;
- c) Yellow;
- d) Green;
- e) Blue.

31. An experimenter finds that 50% of a sample of uranium-238 has decayed. Since uranium-238 has a half-life of 4.5 billion year, the sample's age is about

- a) 4.5 billion years;
- b) 2.25 billion years;
- c) 1.25 billion years;
- d) 9 billion years;
- e) None of the above.

32. Which of the following exhibits the same properties as light?

- a) Microwaves;
- b) Radio waves;
- c) X-rays;
- d) All of the above;
- e) None of the above.

33. Radioactive decay

- a) is always dangerous;
- b) occurs naturally around us all the time;
- c) occurs randomly so it is impossible to accurately predict when an atom decays;
- d) All of the above;
- e) B and C only.

34. The human body radiates the most energy in the form of
- a) visible light; b) infrared radiation; c) X-rays; d) cosmic rays; e) None of the above.

**References:** This Diagnostic Tool was developed by Patricia E. Allen, Appalachian State University for use in the Department of Physics and Astronomy and cannot be used or duplicated without permission of the author. Questions and Figures for this Diagnostic Tool were selected and/or modified from pre-existing diagnostic exams. Specific reference information for each question is available upon request.

## APPENDIX C

**CLASS**  
**(Colorado Learning Attitudes about Science Survey)**

Here are a number of statements that may or may not describe your beliefs about learning physics. You are asked to rate each statement by selecting a number between 1 and 5 where the numbers mean the following:

Strongly Disagree  
Disagree  
Neutral  
Agree  
Strongly Agree

Choose one of the above five choices that best expresses your feeling about the statement. If you don't understand a statement, leave it blank. If you have no strong opinion, choose 3.

**Survey**

1. A significant problem in learning physics is being able to memorize all the information I need to know.
2. When I am solving a physics problem, I try to decide what would be a reasonable value for the answer.
3. I think about the physics I experience in everyday life.
4. It is useful for me to do lots and lots of problems when learning physics.
5. After I study a topic in physics and feel that I understand it, I have difficulty solving problems on the same topic.
6. Knowledge in physics consists of many disconnected topics.
7. As physicists learn more, most physics ideas we use today are likely to be proven wrong.
8. When I solve a physics problem, I locate an equation that uses the variables given in the problem and plug in the values.
9. I find that reading the text in detail is a good way for me to learn physics.
10. There is usually only one correct approach to solving a physics problem.

11. I am not satisfied until I understand why something works the way it does.
12. I cannot learn physics if the teacher does not explain things well in class.
13. I do not expect physics equations to help my understanding of the ideas; they are just for doing calculations.
14. I study physics to learn knowledge that will be useful in my life outside of school.
15. If I get stuck on a physics problem on my first try, I usually try to figure out a different way that works.
16. Nearly everyone is capable of understanding physics if they work at it.
17. Understanding physics basically means being able to recall something you've read or been shown.
18. There could be two different correct values for the answer to a physics problem if I use two different approaches.
19. To understand physics I discuss it with friends and other students.
20. I do not spend more than five minutes stuck on a physics problem before giving up or seeking help from someone else.
21. If I don't remember a particular equation needed to solve a problem on an exam, there's nothing much I can do (legally!) to come up with it.
22. If I want to apply a method used for solving one physics problem to another problem, the problems must involve very similar situations.
23. In doing a physics problem, if my calculation gives a result very different from what I'd expect, I'd trust the calculation rather than going back through the problem.
24. In physics, it is important for me to make sense out of formulas before I can use them correctly.
25. I enjoy solving physics problems.
26. In physics, mathematical formulas express meaningful relationships among measurable quantities.
27. It is important for the government to approve new scientific ideas before they can be widely accepted.

28. Learning physics changes my ideas about how the world works.
29. To learn physics, I only need to memorize solutions to sample problems.
30. Reasoning skills used to understand physics can be helpful to me in my everyday life.
31. We use this statement to discard the survey of people who are not reading the questions. Please select agree-option 4 (not strongly agree) for this question to preserve your answers.
32. Spending a lot of time understanding where formulas come from is a waste of time.
33. I find carefully analyzing only a few problems in detail is a good way for me to learn physics.
34. I can usually figure out a way to solve physics problems.
35. The subject of physics has little relation to what I experience in the real world.
36. There are times I solve a physics problem more than one way to help my understanding.
37. To understand physics, I sometimes think about my personal experiences and relate them to the topic being analyzed.
38. It is possible to explain physics ideas without mathematical formulas.
39. When I solve a physics problem, I explicitly think about which physics ideas apply to the problem.
40. If I get stuck on a physics problem, there is no chance I'll figure it out on my own.
41. It is possible for physicists to carefully perform the same experiment and get two very different results that are both correct.
42. When studying physics, I relate the important information to what I already know rather than just memorizing it the way it is presented.

## APPENDIX D

## CLASS Thematic Grouping of Questions

**Personal Interest**

3. I think about the physics I experience in everyday life.
11. I am not satisfied until I understand why something works the way it does.
14. I study physics to learn knowledge that will be useful in my life outside of school.
25. I enjoy solving physics problems.
28. Learning physics changes my ideas about how the world works.
30. Reasoning skills used to understand physics can be helpful to me in my everyday life.

**Real World Connection**

28. Learning physics changes my ideas about how the world works.
30. Reasoning skills used to understand physics can be helpful to me in my everyday life.
35. The subject of physics has little relation to what I experience in the real world.
37. To understand physics, I sometimes think about my personal experiences and relate them to the topic being analyzed.

**Problem Solving (General and Confidence)**

13. I do not expect physics equations to help my understanding of the ideas; they are just for doing calculations.
15. If I get stuck on a physics problem on my first try, I usually try to figure out a different way that works.
16. Nearly everyone is capable of understanding physics if they work at it.
25. I enjoy solving physics problems.
26. In physics, mathematical formulas express meaningful relationships among measurable quantities.
34. I can usually figure out a way to solve physics problems.
40. If I get stuck on a physics problem, there is no chance I'll figure it out on my own.
42. When studying physics, I relate the important information to what I already know rather than just memorizing it the way it is presented.

**Problem Solving (Sophistication)**

5. After I study a topic in physics and feel that I understand it, I have difficulty solving problems on the same topic.
21. If I don't remember a particular equation needed to solve a problem on an exam, there's nothing much I can do (legally!) to come up with it.
22. If I want to apply a method used for solving one physics problem to another problem, the problems must involve very similar situations.
25. I enjoy solving physics problems.

- 34. I can usually figure out a way to solve physics problems.
- 40. If I get stuck on a physics problem, there is no chance I'll figure it out on my own.

### **Sense Making/Effort**

- 11. I am not satisfied until I understand why something works the way it does.
- 23. In doing a physics problem, if my calculation gives a result very different from what I'd expect, I'd trust the calculation rather than going back through the problem.
- 24. In physics, it is important for me to make sense out of formulas before I can use them correctly.
- 32. Spending a lot of time understanding where formulas come from is a waste of time.
- 36. There are times I solve a physics problem more than one way to help my understanding.
- 39. When I solve a physics problem, I explicitly think about which physics ideas apply to the problem.
- 42. When studying physics, I relate the important information to what I already know rather than just memorizing it the way it is presented.

### **Conceptual Understanding**

- 1. A significant problem in learning physics is being able to memorize all the information I need to know.
- 5. After I study a topic in physics and feel that I understand it, I have difficulty solving problems on the same topic.
- 6. Knowledge in physics consists of many disconnected topics.
- 13. I do not expect physics equations to help my understanding of the ideas; they are just for doing calculations.
- 21. If I don't remember a particular equation needed to solve a problem on an exam, there's nothing much I can do (legally!) to come up with it.
- 32. Spending a lot of time understanding where formulas come from is a waste of time.

### **Applied Conceptual Understanding**

- 8. When I solve a physics problem, I locate an equation that uses the variables given in the problem and plug in the values.
- 21. If I don't remember a particular equation needed to solve a problem on an exam, there's nothing much I can do (legally!) to come up with it.
- 40. If I get stuck on a physics problem, there is no chance I'll figure it out on my own.

## APPENDIX E

**Students Laboratory Evaluation Form (SLEF)**

Course Number \_\_\_\_\_ Section Number \_\_\_\_\_

Laboratory Instructor \_\_\_\_\_

1. Comment on the lab in general.
  
  
  
  
2. Comment on the grading scale.
  
  
  
  
3. Comment on the method of teaching.
  
  
  
  
4. Comment on the laboratory manual.
  
  
  
  
5. Comment on the laboratory instructor.



## APPENDIX F

**End-of-Course Questionnaire Questions (EoCQ)**

1. It was difficult to complete the lab exercises in the allotted time
2. My lab experiences have been very interesting
3. I had to work hard during the lab exercises
4. I enjoyed the lab exercises
5. It was difficult to understand what the procedures told me to do
6. The lab is the least important part of this course
7. I learned a lot from the lab exercises
8. I enjoyed working with the computer-interfaced lab equipment
9. The lab procedures helped me learn physics
10. The lab procedures made it difficult for me to work with partners
11. The lab procedures made me think
12. The lab helped me understand how the experimental process works

## APPENDIX G

## Video Recordings Observations

**Force and Motion**

The actual video recording of classes began on the second week of class. The first week was mostly spent performing diagnostics, going over the rules and regulations, filling out the video and research participation forms, and playing with the probes and sensors. Near the end of the first laboratory period, I handed out the “Not-So-QuickGuide to Motion,” and students began playing with the motion detector for maybe 20 minutes before the end of the period.

There were very few questions of any real depth. Mostly, people just needed help using the equipment. The few questions about the material were more of a “just checking” than an “I don’t understand.” The questions mostly dealt with the graphs, too, particularly the velocity graphs. Everyone seemed to have a grasp on the definitions and equations, but they struggled a bit with the idea of negative and positive velocity and how it relates to the sensor or to a reference point. However, at the same time, I noticed people really looking at the time, counting intervals, trying to be very precise and accurate in their interpretations of physical movements based on the graphs.

The real difficulty and confusion came when it was time for them to experiment on their own with sensors they hadn’t used before. Without being given a direction, most people were slow in getting started with the other sensors on their own. I don’t think they understood the purpose or how they would be graded for it. Many were downright reluctant. I noticed a lot of people starting to write error analyses/conclusions or brainstorm about the constant acceleration problem rather than play with the sensors. However, once they did get

started, people picked up on the new equipment fairly quickly and without too much assistance. It seemed that about half of the class really got into it and figured out ways of using the new stuff to make meaningful measurements or to solve the constant acceleration challenge. The other half only got the equipment working but didn't really know what to do with it. Those that did figure it out also came up with new ways of doing things on their own that were better than the methods we had used previously in our own exploration of the equipment. Everyone was also very worried about finishing and what had to be turned in and when.

The first thing I noticed during the second week was that a lot of people had misplaced their handout from the previous week or didn't bring a lab manual. Obviously lab isn't at the top of their priority list. They didn't really seem bothered about it or seem to think it was important. However, despite that, they all got to work right away when they came in. Everyone seemed to remember how to set up the equipment and use LoggerPro.

This was a very active laboratory. The two hours flew by because I was constantly bombarded with questions, few of which were quick and easy. There were the same hardware/software problems as before, but many, many more conceptual ones. The questions asked, too, were about the concepts at the most basic level. I can't say that everyone even understood the definitions and equations this time, or it could have been that there was a hesitation and lack of confidence. When I was helping one group to set up a New Calculated Column, I asked them the units of velocity, and they all started looking in their book. When I told them just to think about the equation for velocity, a lot of them started laughing, saying "Oh yeah." I think they knew more than they thought they did. However, they could not always support their answers. They tended to spit them out without knowing why. I believe

that a lot of rote learning is going on in their lecture and they want to apply those same methods in lab, applying formulas without really thinking about the experiment.

There was a lot of trouble with graphs. I could tell that they had little experience graphing or were very uncomfortable with math concepts. Nearly everyone had questions about how to recreate the instantaneous changes in velocity that Activity 2 asked for (and which was impossible to perform). I was glad that they were starting to actually think about it.

Again, there was the same difficulty with positive and negative velocity. I found myself having them draw pictures and act out concepts. That seemed to help most people a lot. Part 2, Activity 3 of the “Not-So-QuickGuide to Motion,” was a particular challenge for them. They were required to predict a  $d$  versus  $t$  graph from a  $v$  versus  $t$  graph. I tried to emphasize taking things one step at a time, to try imaging actual points along the lines of the graph, and consider each point individually, to ask what was happening at definite points in time. A lot of repetition was necessary, and many didn't complete the exercise. Most people took their time on the Motion Guide. They didn't try to move through the material as quickly but spent more time discussing and debating the answers and trying to understand the concepts.

I noticed that there were quite a few people in the class that seemed to have taken Physics before. A few of them even knew about the derivative relationships between position, velocity, and acceleration. They were really good about helping the other people at their tables understand the concepts, but were really not much better than the other students at making predictions or explaining observations.

At the beginning of week three, the students jumped right back into the lab. This week's activities dealt with acceleration, and there were multiple stations set up where students could perform the Behr Free Fall experiment with carbon tape and digital video, and also find the constant acceleration using a fan cart, a cart on an inclined track, or a falling tape dispenser. Everyone remembered how to set up the Vernier equipment and use LoggerPro, and in general most were much more prepared for lab. All around, I got a much better vibe from this group. They seemed friendlier and more willing to be a good sport about having to be there.

That week I fielded a lot of questions. I think the students were beginning to be less hesitant. Being stationed at the camera for the majority of the time, I can comment most on student's reactions to the Behr free fall experiment. In general, most students didn't have any trouble operating the camera and computer. The difficulty came because of a lack of patience. When you click the Stop Capture button, it takes the computer a while to write to the camera and read back the response, so it seems like nothing happens for a few seconds. This caused a lot of students to continuously click the button over and over. That only succeeded in starting and stopping the video capture again and again, creating multiple videos on the screen and usually messing up the first one that they wanted. The apparatus itself posed more of a fear than a problem, because of the high-voltage sparking. A few of the students were actually afraid to go near it, but everyone thought it was cool (especially those that actually got to operate the sparker generator). However, because of fear, apprehension, etc., everyone was a bit hesitant. Once the data was acquired, most students obtained good results from the video analysis and didn't have too many questions about it (if they had done the tutorial).

However, most people had no idea what to do with the tape from the Behr machine. After a brief explanation, though, they caught on quickly. The concepts were there. They understood why the dots got farther apart, but they didn't know what type of measurement to take to make a graph. I tried to lead them to the answer by asking them what the differences and similarities were between the video analysis graph and the one they got from the tape. In some cases, it worked. Most students figured out that a quadratic produced the best fit, but there was some difficulty figuring out the meaning of  $Ax^2 + Bx + C$ , the generic quadratic formula generated by Logger Pro's curve fitting function. For some reason, they didn't understand that the constant A represented  $\frac{1}{2}$  acceleration. The students definitely struggled with being able to look at the fit equation from their data and relate it to a kinematic equation. This was not a skill that anyone seemed to have.

In general, though, the students seemed to be warming up to each other and to me. I noticed that some of them would actually come find me now if they had a question, instead of just sitting there and waiting for someone to come around. Also, they seem to be getting into the groove of the lab. There was still some uncertainty about what to do when directions were vague or left open, but eventually, they would jump in and try things on their own. The students were challenged a bit more to find things out on their own.

One thing that surprised me was the fact that these students had a lot of difficulty operating the computer. It wasn't necessarily the program and camera that they had trouble with, but some of them didn't even understand how to use their flash drives and seemed hesitant when it came time to save the file and shut down LoggerPro. I really thought the students were going to be more computer savvy.

Week four was very difficult for the students. They were to design an experiment to show the relationship between force, mass, and acceleration, using a modified Atwood machine. This activity offered the least guidance of any so far, and the students absolutely hated being left to figure out the experiment on their own. I even heard one group commenting that if their lecture instructor were the lab instructor, they would be told exactly what to do and what to expect, but that they just weren't that lucky. I almost laughed out loud. Another group talked to me about how they didn't feel like they had learned anything this semester from lab because they hadn't completed what they called a "successful" lab yet. I tried to explain to them that by figuring it out on their own, making mistakes, experiencing trial and error, that they were learning more and that they were learning how it really was to do research. They didn't seem to buy it. I had noticed that it took them a long time to ask questions because they seemed reluctant to admit they could not figure it out. Then, when they finally did ask questions, they wanted me to tell them everything. I discussed this with them, and they agreed to get help early and often instead of allowing themselves to get completely bogged down.

The students were totally baffled by this lab. Even if they did get data, most of the students didn't know what to do with it, how to make a graph from it and interpret it. I explained using the slope intercept formula, but even that became difficult when force was held constant and the students had to determine the relationship between mass and acceleration. The students were stuck inside these boundaries that had been constructed because they were so used to memorizing an equation and always using it the same way, in the same form. They didn't understand how to make their own equation or how to use valid math laws to manipulate equations they already had. This reminds me of a reoccurring theme

in my education classes that too often undergraduate institutions teach in a way that sets the teacher up as an expert in all things, as someone who passes down packaged knowledge and doesn't allow the student to take any control in the learning process. I think that this happens too often in our general physics classes, too, and the labs. The experimental lab deviated from this method, and the students didn't like it. One of the main things I had seen every week was frustration. A lot of these students were used to doing well and getting good grades, and now they were lost.

On a positive note, the teamwork had really taken off. Everyone seemed to be involved and contributing. I think they all learned a lot about forces and really understood the concepts by the end of lab. A few groups were still straggling at the end, but they had thoroughly covered all possible mistakes that could be made. Sometimes I think that is the most instructional part. Trial and error can be very informative.

### **Work and Energy**

Ironically, the unit on Work and Energy began with a recap of the previous week's treatment of force, mass, and acceleration. I decided to spend the first fifteen minutes revisiting the reason we graph and talking about graphical design and interpretation. The review was sorely needed. My assistant commented that she had the same lack of experience with graphing as they did when she entered college, and that graphs seemed to be "something you hit the highlights on in middle school and never really touch again. Even worse, you never use them to relate to real world situations where correlations have to be made, as well as interpretations that affect decisions" (personal communication with assistant).



That week's activity was to determine the energy of an oscillating spring. I was very pleased with the effort of both experimental sections. When asked to determine the spring constant of helical spring, there were at least four different methods developed. All used Logger Pro in some shape or form. The difficulties most people experienced had to do with calibrating the force sensor and how often they needed to zero the motion detector. One method was to set the spring into oscillation and use Logger Pro to graph a plot of force versus position. I really believe that most people understood the relationship between force, displacement, and the spring constant. Understanding of the graphs and the idea of linear fits didn't scare them anymore. I did have to explain, though, why there was a negative in front of  $k$  and why that didn't mean that the spring constant was negative. Another method was to continually add mass to the spring to allow it to displace further and further and take individual event measurements to plot on their own. This caused a bit of trouble for some people who thought they had to zero the spring each time. Other than that, it was pretty straightforward.

A few people even figured out on their own that if they found the spring constant using the oscillatory method, they didn't have to take any more data. And for the first time, I didn't have any questions about Logger Pro, although there was some confusion with one group about calibration and zeroing. Most of the students used the wrong equation for potential spring energy on their first trial, but figured it out when encouraged to read the introduction more carefully. However, in general, they did well. I think everyone acquired good data and understood what was happening before they left.

The second week of the unit began with an activity requiring students to find the energy of a cart rolling down a track. This involved transforming motion sensor data to

height for potential energy considerations, and I was surprised when no one seemed to remember their basic trigonometric functions, since I know they have been used in the lectures. I couldn't get a feeling, though, for whether they really didn't know or were just being lazy. I did think that some groups were really trying and just getting confused. Others seemed to get themselves worked up and frustrated so that they couldn't think clearly about the problem. Also, they always wanted to know "where are we going with this." However, when I tried using Socratic dialogue, they grew impatient about getting to the point, getting to the answer, instead of trying to understand all the little parts.

I noticed too, that a lot of people had difficulty with understanding the function of variables. They were reluctant to look at the problem and begin assigning variables. Instead, they wanted actual numerical values, and kept saying, "we don't know this" or "we don't have a value for this." There was an assumption that everything should have been given, and they didn't think about "what can I measure myself to get what I need." This carried over into their inability to remember or generalize equations to new situations. Even when they could remember the trig equations, they had difficulty replacing  $o$ ,  $a$ , and  $h$  with different letters, and kept doubting themselves when they ran across a variable they didn't have a value for.

Also, there was an inability to look at the big picture. Many of the groups were getting stuck by thinking about a discrete position along the track. They kept saying, "well if the cart is at 100 cm, then..." It was a challenge for some of them to make the jump to forming an equation that would work for any point on the track. Similarly, it was difficult for them to look at the situation as a whole and determine what was known and what needed to be known.

It was encouraging that they seemed to be truly interested in understanding what was going on. It was like they knew that physics wasn't their strong subject, but they wanted to make a good grade and do the best they could. There was still general "amnesia" when it came to Logger Pro and some of the basic activities we had done the past couple labs. A lot of the students refused to get comfortable with the "New Calculated Column" no matter how often we used it. I think a lot of it comes back to the fact that they aren't very comfortable with computers. I have been surprised at how little these students know about computers and how to use them to do more than check e-mail and Facebook. I always assumed that people my age grew up with computers like I did and were comfortable with them, but I was wrong.

### **Momentum and Collisions**

Unit three began with a lab analyzing the 1-D collisions of carts on tracks. A motion detector and a force probe were used to study impulse and the transfer of momentum. This was the first day that I really didn't have to answer many questions. By now, the students knew how to use Logger Pro, they knew how to set up the equipment, and they even seemed to know how to get the data they needed from the graphs.

The main problems that we had were with a time lag in the readings between the GoMotion sensor and the force probe, and some confusion about the "Interpolate" function. I think hardly anyone had ever heard the word before, much less knew what it meant. Once I explained it to them, however, they immediately knew how to use it to get what they wanted. Another small difficulty was the learning curve in how to push the cart to get it to move constantly and not too quickly. A lot of people were hitting the force probe too hard and causing it to saturate.

The students performed at the usual speed. A few of them finished late, but I think a lot of that was just messing around with the sensors and the carts to get the best graphs. They knew what was going on but took a little longer in getting good data. Again, pretty much everyone set up the equipment immediately and got to work with Logger Pro without help. There were some questions about the graphs, though, especially if they didn't look exactly like someone else had gotten. I think everyone understood the basic concepts, though.

One girl was very disgruntled with her group. I had noticed that in previous weeks she had stayed behind after her partners had left and finished working, doing calculations, etc. She always called me over to clarify things she didn't understand but that her group wouldn't stay behind to discuss or figure out.

At the beginning of the next week's lab, I decided to change up lab groups. I had observed that they were growing too comfortable with their roles and that the same people were beginning to perform the same tasks each week. Leaders had emerged at each table, and the others were becoming more prone to just stand back and watch. Some students were relieved, while others were angry and upset, but it turned out to be a good thing. After an initial awkward stage, the new groups were whirring and humming like they had been at the beginning of the semester.

The next lab was on 2-D collisions, using a video analysis of a collision between air pucks. Again, I was surprised how much trouble people had just operating the computer. One person even asked me how to save the file like there was something special they had to do. There were also plenty of questions about Logger Pro's video analysis software, though that was to be expected.

Once the analysis began, I was amazed at the multitude of ways the students devised to show the conservation of momentum. They really did get creative. They truly were getting better at working without guidance, and that made me really happy! Over the past few periods, I had really been able to tell a difference in both sections of the experimental lab. The students had not asked as many questions, and the questions were much less repetitive and predictable. I believe that they were starting to catch on to the idea of self-guided inquiry.

### **Rotation**

The first lab in the unit on Rotation was a set of activities involving a meter stick on a pivot. Different masses were placed at various distances from the fulcrum to establish rotational equilibrium. The most common problems were using the wrong radius, not understanding how center of mass works, and not understanding why the meter stick exerted no torque when its center of mass was on the fulcrum. The traditional sections also performed this lab, except with the assignments written in the cookbook style.

The final activity of this lab was extremely telling. The experimental and traditional sections were both given the same problem: to devise an experiment using rotational equilibrium to determine the mass of the meter stick. This was the first time that the experimental and traditional students had been pitted toe-to-toe in a design problem, and the students in the experimental sections won this bout handily. They immediately began moving masses, brainstorming with their partners, and handily solving the problem using diverse methods. No two groups came up with the same solution!

The students in the traditional sections, however, were totally flummoxed. They had no idea of what to do, and it required much explaining and hand-holding on my part to even get them started. The traditional groups all ended up solving the problem in the same way – the way my assistant and I told them to do it. It really made me realize how far the experimental sections had come since that terrible  $F = ma$  laboratory at the end of the unit on Force and Motion.

The second week of the unit on Rotation dealt with centripetal force. Since the “competition” between traditional and experimental sections had been so interesting the week before, I gave the experimental sections a set of conical pendulum activities that were almost exactly like the ones presented in the lab manual. There were almost no complaints about the lack of directions, although there was definitely some confusion about the differences in the three centripetal force activities. And of course, they still needed the extra nudge to get going with the trigonometry. However, I believed that the experimental sections were finally able to bridge the gap between theory and application. They were understanding concepts instead of spitting out memorized information, and also forming connections between old and new information. Their lab reports were also reflecting an increased understanding. At this point in the semester, their reports were far superior to those of the traditional sections.

### **Sound and Simple Harmonic Motion**

By the time the unit on Sound and Simple Harmonic Motion came around, the experimental sections had all but come through the labor pains of physics by inquiry. They now knew what to expect, and were comfortable with being in charge of their own learning

and understanding. They entered lab, looked up the web site, and began experimenting almost immediately. They were working fluidly in groups, and thinking about concepts before asking questions. They were not worried about making mistakes or setting up an experiment so poorly that no results would be attained. They seemed confident that they would be able to solve the presented problems.

The activities of the unit centered on the idea of standing waves, and once they had put their heads together to complete the first activity, the other activities seemed to pose few problems. I was surprised at the rate of transferability the students demonstrated as they moved from concept to concept. The traditional sections performed the same activities, but were unable to make the same connections. To them, each activity seemed a separate entity, requiring its own unique set of equations and steps for completion, and the students never got the sense of connectivity demonstrated by their counterparts in the experimental sections. For example, they did not seem to draw any similarities between determining the linear density of a string or calculating speed of sound in a variable-length tube. The experimental sections, however, understood that both required the student to find the lengths of standing waves that varied with tension or frequency and use that information to graphically determine a constant.

### **Practicum**

At the close of the semester, the experimental sections performed a practicum laboratory which was totally unguided and which required them to experimentally determine the elastic limit of a spring. When the practicum was first developed, I thought it was going to be too difficult. First of all, it was a new concept that hadn't been covered in class, and

secondly, there were only external references for the students to get information from. It has been my experience that for the most part, the students don't like reading through a lot of external material, even when it is obvious that it might be helpful or make things easier.

However, after the initial shock of "what am I going to do," most everyone did pretty well. Some of the major problems involved interpreting the graphs and remembering Hooke's law and the types of measurements that were valid. A lot of people made the  $\Delta L$  measurements a lot more difficult than need be by measuring the length of the entire spring, as well as taking the weights off after every new mass was added to measure a deformation. I don't think it quite sank in that they could just take measurements and then analyze the graph. But it was interesting to see how the deformation increased and by how much it changed with each new force.

As usual, I was surprised to see how many different ways they could think up to measure the same thing. The most inventive one involved lying the spring horizontally on the table while still connected to the force probe and placing a motion detector "below" it. Then, they just pulled on it with a constant motion and recorded the displacement on Logger Pro. The trick to it, though, was changing the setting in Logger Pro for the motion detector to "reverse." That way their graph looked the way they expected. Some people used the motion detector but still hung the spring vertically. That worked, as well, but there was a larger risk of damaging the detector by dropping the masses. Another method people used was just to hang the spring without the force probe and calculate masses by hand. It worked equally well. Many students commented that this was their favorite lab of the entire semester. I was extremely pleased with the outcome, and actually looked forward to grading their reports.



After a long semester of frustration and sometimes despair, I finally felt that these inquiry-based labs had been an unqualified success.

## APPENDIX H

## QuickGuides

## Not-so-Quick Guide to Motion

### INTRODUCTION

One of the probes and sensors you will use during this course is a “motion detector” which is similar to a miniature radar gun. Although you will not be finding the speed of cars racing down River Street, the motion detector can be used to plot real-time graphs of readily available items in the laboratory: you, a toy buggy, a ball, a cart, etc.



A radar gun sends out radio waves that bounce off a speeding car, sending the signal back to the police thus determining the speed of the car. This is the same type of gun used to determine the speed of a baseball pitch. To learn more about radar guns, type in “radar gun” using a search engine like Google.

Unlike a radar gun, which sends out radio waves, the motion detector sends out sound waves. The motion detector used in the laboratory sends out sound waves in the ultrasonic range (above human hearing). To do this, there is a thin piece of ceramic inside the detector that vibrates at a high frequency when an electrical signal is given to it. This is similar to what happens in most speakers found in cell phones, portable speakers, and computers. In addition, the ceramic will vibrate when sound waves hit it to produce electrical signals that can be used by a computer or other electronic device. This is the idea behind how a microphone works.

The ceramic piece inside the motion detector does double duty: it vibrates to send out a sound wave, then turns off to detect any sound waves that return to it. This is the source of the audible “clicking” the motion detector makes when it is in use. The computer records when a signal is sent and when it is detected to determine the time it takes to go from the detector to the object and back. The computer also knows the speed of sound in air (around 770 mph or 350 m/s). The computer then calculates the distance the object is from the motion detector.

This is also the idea behind ultrasound imaging. Unlike the motion detector used in lab that has only one ceramic piece, medical ultrasound probes use multiple ceramic pieces to generate complex images of inside a body. The probe sends sound waves into the body. (Sound waves travel about four and a half times faster in the human body than in air.) The sound waves will reflect from the different materials (called interfaces) inside the body and return to the probe where a computer records the time it takes to return from each interface. Each interface indicates where different materials meet, so the location of internal structures can be determined with great precision.

### OBJECTIVES

- Analyze and understand the motion of various situations including, but not limited to: a student walking, a rolling cart, etc.
- Predict, sketch, and test position vs. time graphs.
- Predict, sketch, and test velocity vs. time graphs.
- Predict, sketch, and test acceleration vs. time graphs.
- Distinguish between:
  - speed and velocity
  - distance traveled and displacement
  - velocity and acceleration



- +/- and toward/away
- average and instantaneous values (like velocity, acceleration)

## NECESSARY EQUIPMENT

Computer  
Universal Lab Interface  
*Logger Pro*

Vernier motion detector  
meter stick  
masking tape

## PRELIMINARY STEPS

To prepare for the activities in this guide, you will need to do the following:

- Connect the Motion Detector to Dig/Sonic 1 of the LabPro interface.
- Place the motion detector so that it points toward an open space at least 4 m long.
- Prepare the computer for data collection: In *Logger Pro*, open the file "01a Graph Matching" from the Physics with Computers folder. A graph of position vs. time should appear.
- Test out the equipment! Using *Logger Pro*, produce a graph of your motion when you walk away from the detector. To do this, stand about 1 m from the Motion Detector and have your lab partner click . Walk slowly away from the Motion Detector when you hear it begin to click. Then walk toward the motion detector. You should see a graph of your motion. If you have difficulty, contact your instructor.
- The following activities will help you become more comfortable with the motion detector and with the various quantities important for motion.

## ACTIVITIES

The following activities will help you become familiar with the motion detector and how it can be used to determine a variety of physical quantities. Do as many of the activities in each Part so that you can answer questions about the motion detector **AND** about basic physics principles pertaining to the motion of an object, consistent with the objectives stated above. However, should you have some different ideas as to how to accomplish the above objectives, check with your instructor before trying out your ideas.

**NOTE:** For the various sections of this activity guide, you will need to make sketches of graphs, describe the motion, and/or include an explanation (complete with graphs and supporting verbiage) as to what happened. You will also be asked to make predictions based on information provided to you.

### PART I: Position and Time

Prepare the computer to collect position (d) and time (t) information.

#### Activity 1

Sketch a d versus t graph of your prediction for each of the following situations in Table I.1.

**Table I.1: Walking activities 1**

<b>Activity Description</b>	<b>Graphical Sketch</b>	<b>Explanation/Results/Discussion</b>
Standing still		
Slowly and steadily moving away from the detector		
Slowly and steadily moving toward the detector		
Quickly and steadily moving toward the detector		
Quickly and steadily moving away from the detector.		

Do each of the previous actions by having members of the group walk the prescribed motion.

In the “Explanations” section in Table I.1 above, include your results, including any graphs, explanation and/or discussion about whether or not the actual result was similar to your prediction.

In the space below, write a paragraph summarizing your observations for moving toward and away from the detector.

**Activity 2**

Make the following adjustment to the motion detector: Select “Experiment” from the menu, then select “Set up sensor” to select “LabPro.” You’ll see a picture of the LabPro with the Dig/Sonic 1 box containing the motion detector. When you click on the motion detector icon, you’ll see a menu with one of the items being “Reverse Direction.” Select “Reverse Direction.”

Sketch a  $d$  versus  $t$  graph of your prediction for each of the following situations in Table I.2.

**Table I.2: Walking activities 2**

Activity Description	Graphical Sketch	Explanation/Results/Discussion
Quickly and steadily moving toward the detector		
Quickly and steadily moving away from the detector.		

Do each of the previous actions by having members of the group walk the prescribed motion.

In the “Explanations” section in Table I.2 above, include your results, including any graphs, explanation and/or discussion about whether or not the actual result was similar to your prediction.

In the space below, summarize your observations for moving toward and away from the detector using the new referencing direction. In particular, distinguish between “+ and –” directions and “toward and away.”

**Activity 3**

Describe (predict) the activity required to match the given graphs. Before starting, make sure to indicate in which direction you have designated as positive (+).

**Table I.3: Walking activities 3**

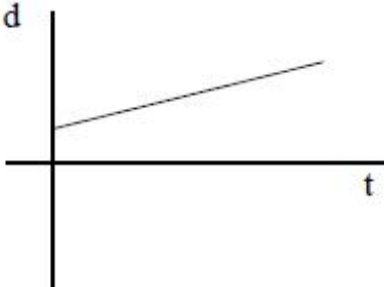
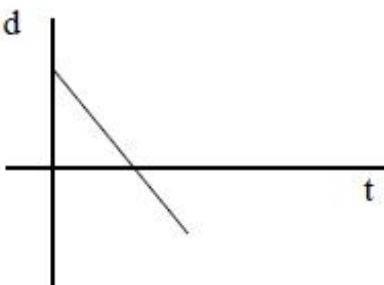
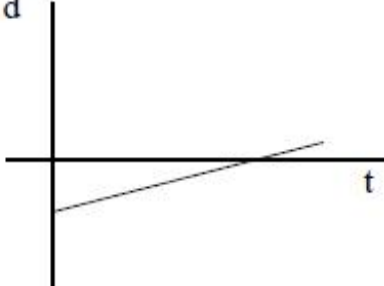
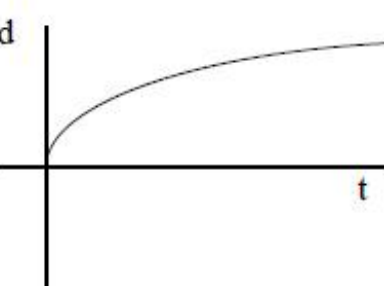
Activity Description	Graphical Sketch	Explanation/Results/Discussion
	 <p>A coordinate system with a vertical axis labeled 'd' and a horizontal axis labeled 't'. A straight line with a positive slope starts at a point on the 'd' axis above the origin and extends upwards and to the right.</p>	
	 <p>A coordinate system with a vertical axis labeled 'd' and a horizontal axis labeled 't'. A straight line with a negative slope starts at a point on the 'd' axis above the origin and extends downwards and to the right.</p>	
	 <p>A coordinate system with a vertical axis labeled 'd' and a horizontal axis labeled 't'. A straight line with a positive slope starts at a point on the 'd' axis below the origin and extends upwards and to the right.</p>	
	 <p>A coordinate system with a vertical axis labeled 'd' and a horizontal axis labeled 't'. A curve starts at the origin (0,0) and increases with a decreasing slope, resembling a concave-down function.</p>	

Do each of the previous actions by having members of the group walk the prescribed motion.

In the "Explanations" section in Table I.3, include your results, including any graphs, explanation and/or discussion about whether or not the actual result was similar to your prediction.



In the space below, provide an overview of the similarities and differences between speed and velocity. Make sure to include how you could determine speed and velocity from your  $d$  vs  $t$  graphs.

#### Activity 4

For this activity, you will be using a file from *LoggerPro*. Open up the file "01b Graph Matching" from the "Physics with Computers" folder. The distance versus time graph should resemble the given graph (Matching Graph I).

In the space provided, describe how you would have to move to reproduce Matching Graph I.

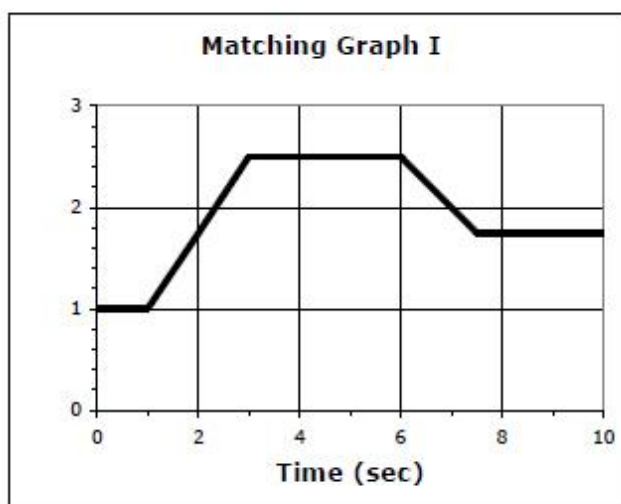

Have each person attempt to reproduce Matching Graph I.

On the graph, sketch your group's best attempt at matching the graph. In the space provided below, discuss any issues you or your group had in matching the graph and how those issues were resolved.

Time (and interest) permitting, repeat the  $d$  vs  $t$  matching activity given above for file "01c Graph Matching" from the "Physics with Computers" folder.

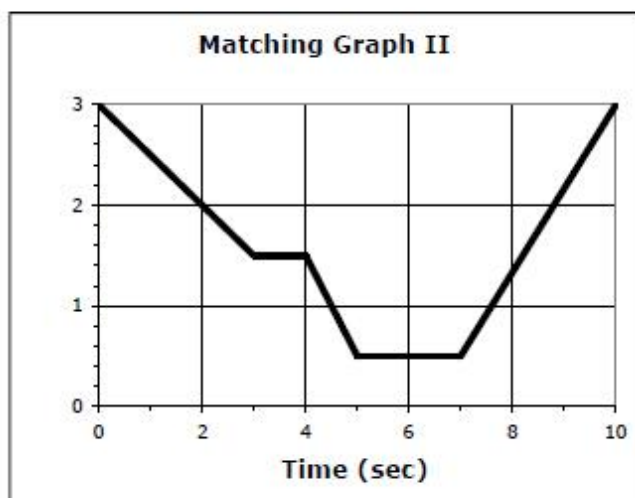

**PART II: velocity and time**

- Prepare the computer to acquire  $d$  vs  $t$  information.
- For this part of the activities, you will need to add a second graph, one that displays the velocity of an object as a function of time. Insert a new Graph. Rearrange and adjust the graphs so that you have both " $d$  vs  $t$ " and " $v$  vs  $t$ " graphs equally displayed at the same time. The best arrangement is to have " $d$  vs  $t$ " stacked above " $v$  vs  $t$ " so you can compare the two types of graphs for the same time interval.

**Activity 1**

Describe/predict the  $d$  vs  $t$ , and velocity versus time graphs for the given situations. Place your predictions, including any graphs, in Table 11.1. (Be able to provide a verbal description/explanation of the  $v$  vs  $t$  graph when asked. For example, "Walking with constant velocity is a horizontal line [or line with zero slope] where speed and direction can be found by....")

**Table II.1: Walking activities 1**

Activity Description	Graphical Sketches	Explanation/Results/Discussion
Standing still		
Slowly and steadily moving toward the detector		

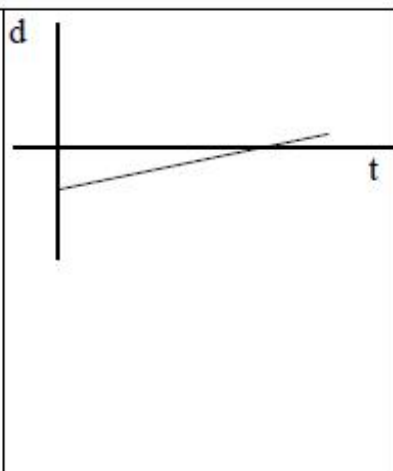
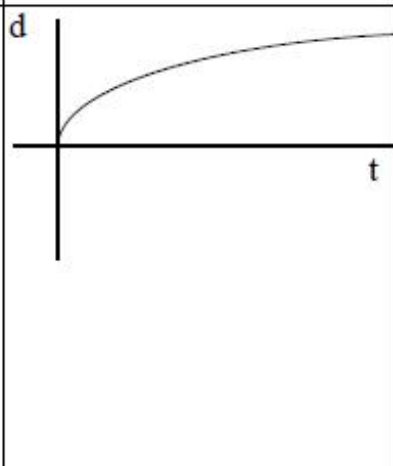

		
<p>Quickly and steadily moving away from the detector.</p>		
		

Do each of the previous actions by having members of the group walk the prescribed motion.

In the “Explanations” section in Table II.1 above, include your results, including any graphs, explanation and/or discussion about whether or not the actual result was similar to your prediction.

Briefly discuss any patterns you may have noticed between the  $d$  vs  $t$  &  $v$  vs  $t$  graphs for each situation.

Are there any situations in Table II.1 when the group member was moving with *constant velocity*? How do you know?

### Activity 2 (Optional)

This activity is similar to Activity 4 in Part I above. However, your group will generate its own Matching Graph. In Table II.2, sketch in your  $d$  vs  $t$  graph, description of the motion, and your prediction for the  $v$  vs  $t$  graph.

**Table II.2: Matching graph**

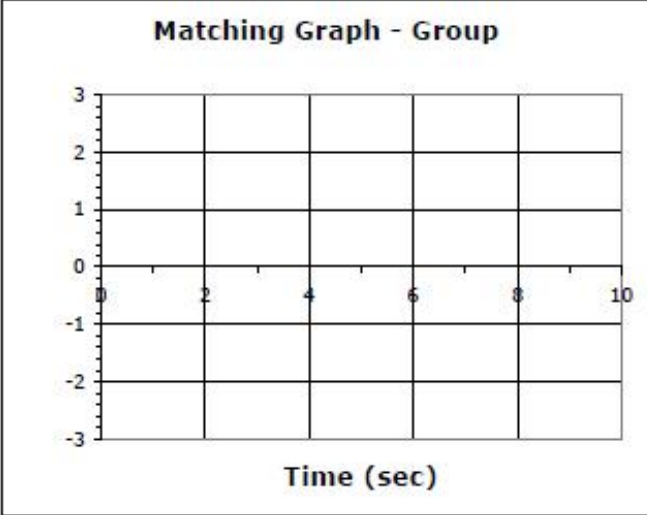
Activity Description	Graphical Sketches	Explanation/Results/Discussion
	 <p style="text-align: center;"><b>Matching Graph - Group</b></p> <p style="text-align: center;">Time (sec)</p>	

Match the above graph by having a group member walk the prescribed motion.

In the “Explanations” section in Table II.2, include your results, including any graphs, explanation and/or discussion about whether or not the actual result was similar to your prediction.

**Activity 3**

For the given  $v$  vs  $t$  Matching Graph shown in Table II.3, describe the motion and predict the  $d$  vs  $t$  graph.

**Table II.3: Matching graph**

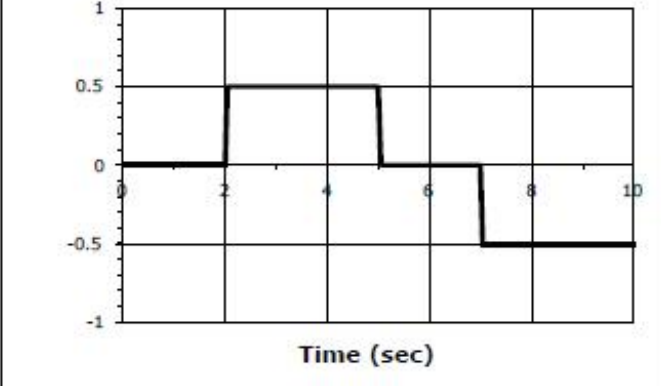
Activity Description	Graphical Sketches	Explanation/Results/Discussion
	<p style="text-align: center;"><b>Matching Graph IV</b></p> 	

Match the above graph by having a group member walk the prescribed motion.

In the “Explanations” section in Table II.3, include your results, including any graphs, explanation and/or discussion about whether or not the actual result was similar to your prediction.

Describe how you can use information to determine the displacement of an object (how far it has moved from its initial to final locations).

Describe how to determine the distance traveled by an object (imagine wearing a pedometer).

Determine the walker’s displacement from 0.5 to 4 sec. Verify your result from the  $d$  vs  $t$  graph.

Determine the walker's distance traveled from 0.5 to 8 sec.

Determine the displacement of the walker from 0.5 to 8 sec. Compare with the distance traveled.

Determine the average velocity AND average speed for the walker from 0.5 to 8 sec.

Explain the difference between average speed and average velocity.

#### **Activity 4**

Arrange the motion detector for viewing the motion of an object moving upward (or downward) with constant velocity. Predict the  $d$  vs  $t$  graphs in Table II.4.

**Table II.4: Vertical motion**

<b>Activity Description</b>	<b>Graphical Sketches</b>	<b>Explanation/Results/Discussion</b>

Match the above graph by having a group member move an object upward (or downward).

In the “Explanations” section in Table II.4, include your results, including any graphs, explanation and/or discussion about whether or not the actual result was similar to your prediction.

How do you know from the  $d$  vs  $t$  and from the  $v$  vs  $t$  graphs that the object is moving with constant velocity?

Is there any way to tell from the  $d$  vs  $t$  or the  $v$  vs  $t$  graphs whether the object is moving horizontally or vertically? Explain.

**PART III**

- Prepare the computer to acquire  $d$  vs  $t$  and  $v$  vs  $t$  information.
- Prepare the motion detector to acquire data for horizontal motion.
- For this part of the activities, include a 3<sup>rd</sup> graph ( $a$  vs  $t$ ). Make sure it can be displayed at the same time as  $d$  vs  $t$  and  $v$  vs  $t$  graphs.

**Activity 1**

Use one of the low friction carts provided. Predict the motion of the cart AFTER you release it from a gentle push. Make sure to indicate direction. Include your predictions for  $d$  vs  $t$ ,  $v$  vs  $t$ , and  $a$  vs  $t$  graphs.

**Table III.1: Low friction cart**

Activity Description	Graphical Sketches	Explanation/Results/Discussion

Gently push the cart. Record the cart's motion AFTER it has been released from your push.

In the “Explanations” section in Table III.1, include your results, including any graphs, explanation and/or discussion about whether or not the actual result was similar to your prediction.

Does the cart move with constant velocity? Support your answer by using information from all three graphs.

**Activity 2**

Add a fan onto the cart. Predict the motion of the cart AFTER you release it from a gentle push. Make sure to indicate direction. Include your predictions for  $d$  vs  $t$ ,  $v$  vs  $t$ , and  $a$  vs  $t$  graphs.

**Table III.2: Low friction cart with fan**

Activity Description	Graphical Sketches	Explanation/Results/Discussion



Gently push the cart. Record the cart's motion AFTER it has been released from your push.

Change direction of fan. Repeat the above activity. Record your information on separate paper. Briefly discuss similarities and differences to the previous activity.

Change direction of push. Repeat the above activity. Record your information on separate paper. Briefly discuss similarities and differences to the previous activity.

Change direction of fan. Repeat the above activity. Record your information on separate paper. Briefly discuss similarities and differences to the previous activity.

[Make sure to do all four possibilities: fan in same direction as push; fan in opposite direction as push; push in opposite direction as the first trial, but with cart in same direction; and push in opposite direction as the first trial, but with cart in opposite direction.]

Briefly summarize the four situations. Make sure briefly discuss the similarities and similarities.

Did the cart in any of the four situations move with constant velocity? Support your answer by using information from all three graphs ( $d$  vs  $t$ ,  $v$  vs  $t$ , and  $a$  vs  $t$ ).

Did the cart in any of the four situations move with constant acceleration? Support your answer by using information from all three graphs ( $d$  vs  $t$ ,  $v$  vs  $t$ , and  $a$  vs  $t$ ).

Explain the difference between velocity and acceleration.



## QuickGuide to the Vernier Motion Detector



The Motion Detector uses ultrasound to measure distance. Ultrasonic pulses are emitted by the Motion Detector, reflected from a target, and then detected by the device. The time it takes for the reflected pulses to return is used to calculate position, velocity, and acceleration. This allows you to study the motion of objects such as a person walking, a ball in free fall, or a cart on a ramp.

Helpful tip: The most frequently reported problems with a Motion Detector are:

1. that the Motion Detector does not work beyond a certain distance or that the graph is very noisy. If your motion detector has a Sensitivity Switch, set the Sensitivity Switch to the other position and retry the experiment. This change may solve the problem.

2. The Motion Detector does not work beyond a certain distance, e.g., it does not detect anything beyond 1.2 m. Here are some things to check if you have this problem:

- Check for movable objects (textbooks, ring stands, etc.) in the cone of the ultrasound. If possible, move these objects out of the measurement cone. It may not take a very large object to cause problems.
- Check for a stationary object (chair, table, etc.) in the cone of the ultrasound. This object may be detected when you are trying to study an object further away. It may not take a very large object to cause problems. If you have trouble with a stationary object causing unwanted echoes, try setting the equipment up so that the objects are not in the cone or placing a cloth over the object. This minimizes the ultrasound reflection.
- Also note that the cone of ultrasound extends downward from the center line. This can cause problems if you are using the Motion Detector on a hard, horizontal surface. In these cases, try pivoting the head of the Motion Detector to aim it slightly upward.

3. Noisy or erratic data may have a number of causes. Here are some tips.

- Sometimes other sound sources can cause problems. If there is another source of ultrasonic waves in the same frequency range, this will cause erroneous readings. Examples include motors and fans, air track blowers, the sound made by the air exiting the holes on an air track, etc. Try to eliminate these sources of noise. If you

- are using an air track, try changing the air flow volume. Make sure that the Motion Detector is not placed close to a computer or computer monitor.
- If the room in which the Motion Detector is being used has a lot of hard, soundreflecting surfaces, you can get strange effects caused by the ultrasound bouncing around the room. Standing waves can be set up between the Motion Detector and a sound reflector. Try placing a cloth horizontally just in front of and below the Motion Detector. This sometimes helps eliminate ultrasound that is "skipping" into the Motion Detector.
  - Try changing the data collection rate. Sometimes Motion Detectors work better at one data rate than another. Rates above 30 Hz do not work well in acoustically live rooms.

If you are studying people moving, have them hold a large, flat object (e.g., a large book or a pizza box) as a reflector. If you have an irregular reflecting surface, sometimes the waves will be reflected back to the transducer, and sometimes not. The results will seem erratic.

## QuickGuide to distance and displacement

**Displacement** is change in position from the final position to the initial position. Basically, it indicates how far something has been moved from its starting position, including both the length and direction of a hypothetical motion along a straight line from the reference point to the actual position. **Distance** indicates the entire amount of ground covered as an object moves from its starting position (see the diagram below). Displacement is a vector quantity: it has direction and magnitude. In one dimension, there are only two possible directions which can be specified with either a plus or a minus sign. Distance cannot be negative. It is a scalar quantity, containing only magnitude. A motion along a curved line cannot be represented by a single displacement vector, and may be described as a sequence of very small displacements.

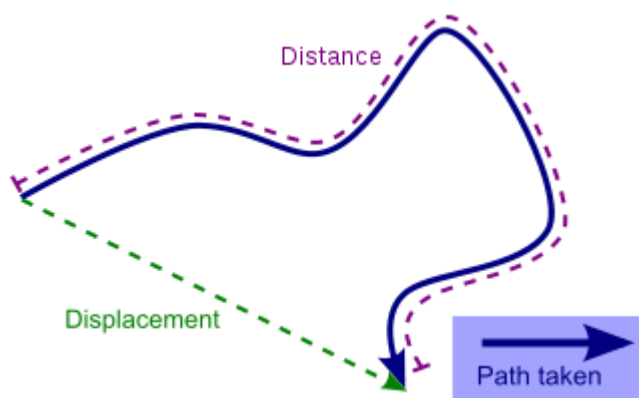

For activities relating to distance and displacement, refer to the Not-so-quick Guide to Motion.

## QuickGuide to Vectors: Solving Analytically

There are various methods for determining the resultant of two or more forces acting at a point. A vector may be represented by the sum of its components. In Fig. (1), you can see the horizontal and vertical components of vector  $\mathbf{A}$ . In a rectangular coordinate system  $\mathbf{A} = A_x\mathbf{i} + A_y\mathbf{j}$ , where  $\mathbf{i}$  and  $\mathbf{j}$  are unit vectors in the x and y directions respectively.  $A_x\mathbf{i}$  is the component of vector  $\mathbf{A}$  in the x direction, and  $A_y\mathbf{j}$  is the component of vector  $\mathbf{A}$  in the y direction. If the magnitude and direction of the vector  $\mathbf{A}$  are known, then the components may be found as follows:

$$A_x = |\mathbf{A}|\cos(\alpha) \quad (1)$$

$$A_y = |\mathbf{A}|\sin(\alpha) \quad (2)$$

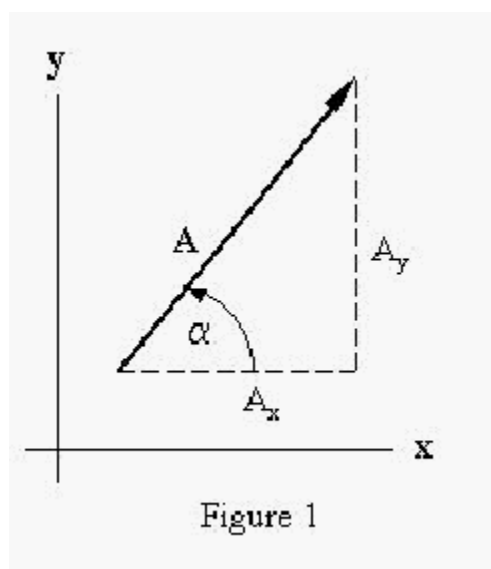

Where  $\alpha$  is the angle of direction with respect to the x-axis. If the components are known, the magnitude of the vector can be found using the Pythagorean Theorem, and the direction can be found using trigonometry.

$$|\mathbf{A}| = \sqrt{A_x^2 + A_y^2} \quad (3)$$

$$\alpha = \tan^{-1}(A_y / A_x) \quad (4)$$

Using these analytical methods, vectors can be added and subtracted by adding and subtracting the components. Consider the two vectors in figure 2. Vectors  $\mathbf{A}$  and  $\mathbf{B}$  are added to form a resultant vector  $\mathbf{R}$ .  $\mathbf{A}$  and  $\mathbf{B}$  could represent forces on the force table. In order to determine the components of the resultant, the horizontal and vertical components of  $\mathbf{A}$  and  $\mathbf{B}$  must be added.

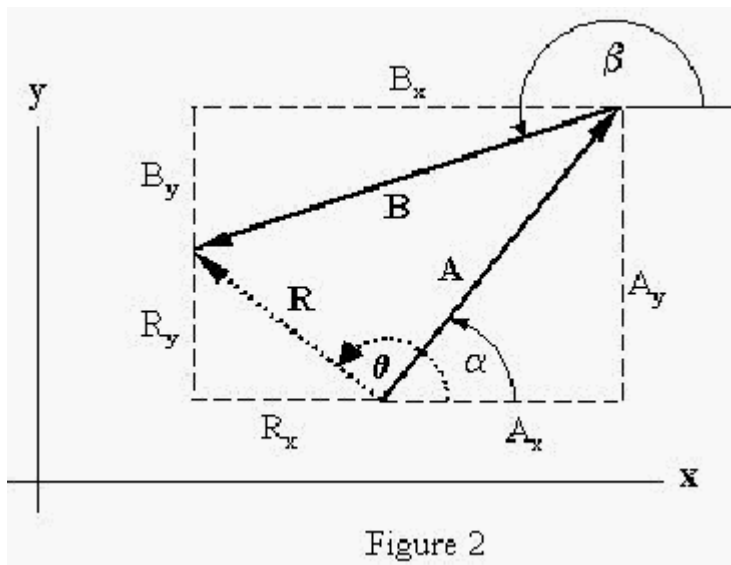

$$R_x = A_x + B_x = |\mathbf{A}| \cos(\alpha) + |\mathbf{B}| \cos(\beta)$$

$$R_y = A_y + B_y = |\mathbf{A}| \sin(\alpha) + |\mathbf{B}| \sin(\beta)$$

$$|\mathbf{R}| = \sqrt{R_x^2 + R_y^2}$$

$$\theta = \tan^{-1}(R_y / R_x)$$

Note that  $\alpha$  and  $\beta$  are measured with respect to the x-axis! Once the components of  $\mathbf{R}$  are known, the magnitude and angle  $\theta$  may be found using equations (3) and (4), respectively. The equilibrant can be found simply by adding  $180^\circ$  to the resultant angle. This same method may be used to add or subtract any number of vectors.

The resultant vector may also be found graphically by simply plotting  $\mathbf{A}$  and  $\mathbf{B}$  and then measuring  $\mathbf{R}$  and  $\theta$ .

## QuickGuide to Vectors: Distances

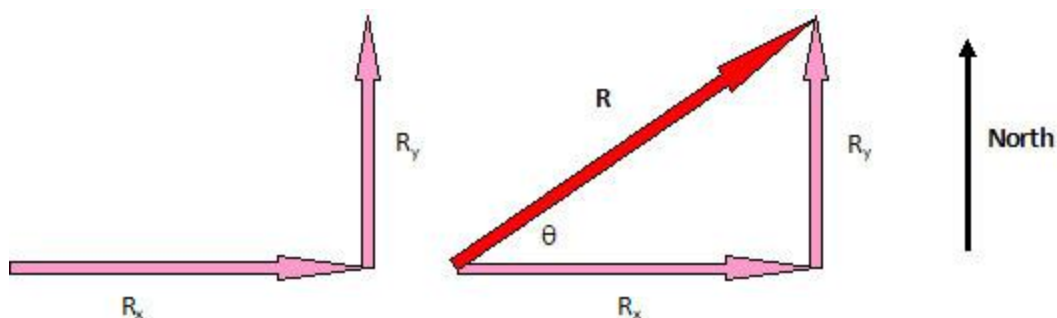

In the above diagram, an explorer hikes trail  $R_x$  from a beginning point 15.0 kilometers due east, and then turns due north on trail  $R_y$  for 13.0 kilometers. The red vector,  $\mathbf{R}$ , represents the shortcut the explorer could have taken.  $\mathbf{R}$  also represents the total displacement, or distance "as the crow flies," of the explorer from the starting point. By calculating the distance  $R$  and the angle  $\theta$ , the explorer can map the shortcut.

1. What was the total distance walked by the explorer?
2. What is the displacement of the explorer? (In other words, what are the distance and the angle of the shortcut from the starting point.) Determine  $\mathbf{R}$  and  $\theta$ .

Check your answer: Open the PhET java applet and select Component Display: Style 2. Make sure the "Show Grid" box is checked and the "Show Sum" box is unchecked. Grab a vector out of the bucket and use it to recreate the path above.

3. Do your answers match? If not, go back and check your understanding.

Let's now say that the explorer started back at the beginning point again and hiked the shortcut  $\mathbf{R}$ . (Because we are going to add another vector, we'll now refer to this path as  $\mathbf{R1}$ .) Then the explorer turned and chartered a course 11.3 km Northwest, as shown by  $\mathbf{R2}$  in the diagram below. Now the explorer would like to know her new displacement.

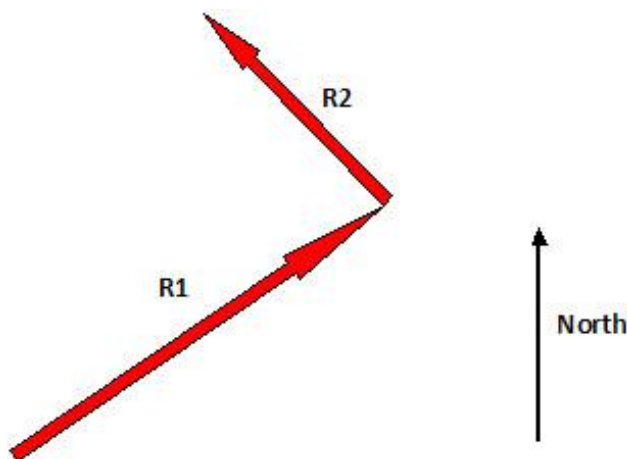

It is difficult to add  $\mathbf{R1}$  and  $\mathbf{R2}$  as they are, because they do not lie in the same line. One solution is to discover the total North-South distance traveled and the total East-West distance traveled, as if the explorer could only take those directions and no shortcuts. Then the x directions can be added like scalars, and the y directions can be added like scalars.

These directions correspond with y and x values on a 2-D coordinate plane. The explorer already knows the values of  $R1_x$  and  $R1_y$  from the previous hike. The diagram below includes vectors  $R2_x$  and  $R2_y$ , which are the x and y components of  $\mathbf{R2}$ .

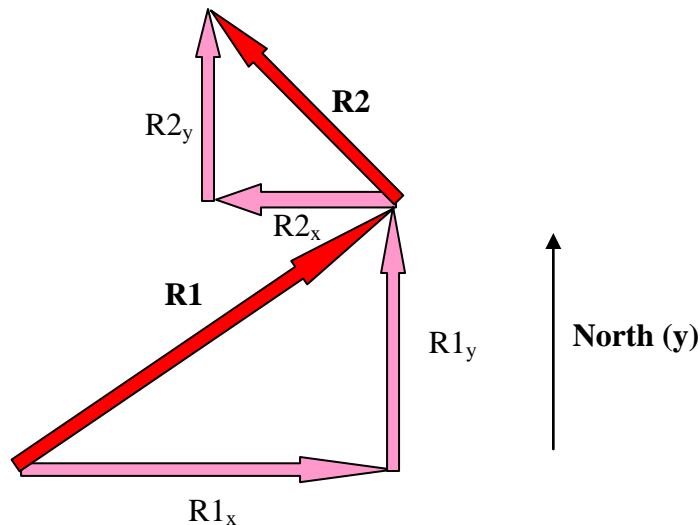

4. Calculate  $R2_x$  and  $R2_y$ . For help with these calculations, please see the QuickGuide to Vectors: Solving Analytically.

5. What is the total displacement in the x (East-West) direction?

6. What is the total displacement in the y (North-South) direction?

7. The explorer can now calculate a shortcut from the beginning to the end. Calculate the total displacement of the explorer. (In other words, the distance and the angle of the shortcut from the starting point.)

Check your answer: Open the PhET java applet and select Component Display: Style 2. Make sure the "Show Grid" box is checked and the "Show Sum" box is unchecked. Grab two vectors out of the bucket and use them to recreate the path above. Now grab a third vector and use it to represent the new shortcut, or the displacement of the explorer from start to finish.

8. Do the angle and magnitude of this vector match the values you calculated in step 6? If not, go back and check your understanding.

In your room, there is a marker representing the starting point for an explorer. There is another point in the hallway representing the end point. Using the two-meter sticks, make a path from beginning to end.

9. Draw a map of the path you took to reach the end.

10. What was your total distance traveled?

11. What was your final displacement (distance and angle from the starting point)?

## QuickGuide to Vectors: Forces

When one or more forces act on an object, the sum of these forces is called the *resultant* force. The resultant force is also called the *net* force. If there is an imbalance of forces, there will be an acceleration.

To prevent acceleration, another force may be added which causes the net force to be zero. This force, called the *equilibrant* force, has the same magnitude and is in the opposite direction of the resultant of all the other forces.

When two or more forces are acting on an object with no net force, then each force is therefore the equilibrant of all the other forces.

In this activity, you will pull on spring scales in order to practice vector addition. Calibrate three spring scales connect them to each other by a string knotted in the center.

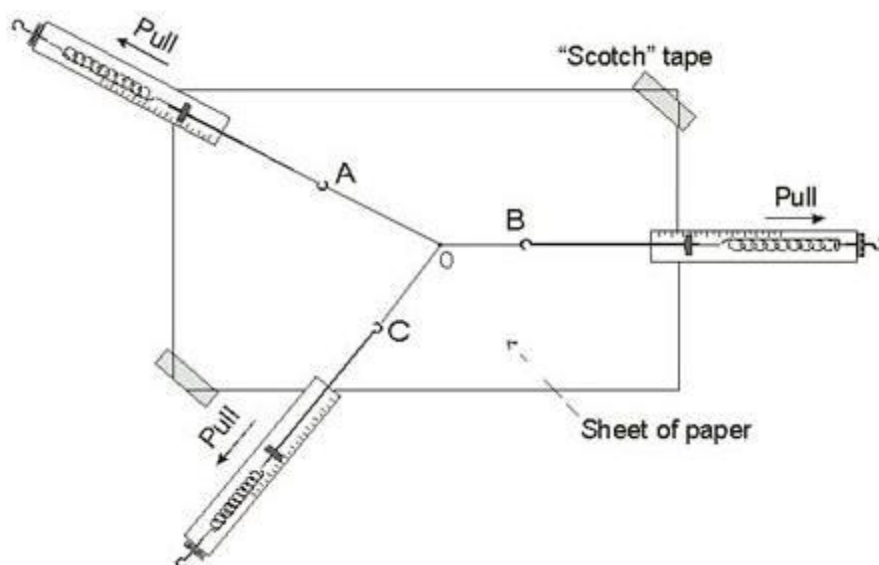

In the diagram above, the three spring scales are being pulled in different directions, but point O is stationary. Therefore, the net force is zero. Perform the above experiment, using a protractor to measure the angles, and show that

1. Force A is the equilibrant of the sum of Forces B and C
2. Force B is the equilibrant of the sum of Forces A and C
3. Force C is the equilibrant of the sum of Forces A and B
4. Repeat steps 1-3 using different forces and angles.

## QuickGuide to the Vernier Dual Range Force Sensor



The Dual Range Force Sensor is a general-purpose device for measuring forces. It can be used as a replacement for a hand-held spring scale. The Force Sensor can measure both pulls and pushes from .01 newtons to 50 newtons.

### Activity 1: Calibrating the sensor

Plug the Vernier Force Sensor into the LabPro. Power up the LabPro and connect it to the PC. Open Logger Pro. If the sensor is not automatically detected, click the 'Lab Pro' button. A picture of the interface box will appear. From the lists of sensors, find the Vernier Force Sensor and drag it to the button that represents the appropriate slot.

If you want to improve the calibration, it is easy to recalibrate. Follow the same procedure used in calibrating most Vernier sensors--a two point calibration. One of the points is usually with no force applied. Select the calibration option in Logger Pro and remove all force from the sensor. Enter 0 as the first known force. Now apply a known force to the sensor. The easiest way to do this is to hang a labeled mass from the hook on the end of the sensor. Enter the weight of the mass (note: 1 kg applies a force of 9.8 newtons). For calibration using the  $\pm 10$  N range, Vernier recommends using 300 g of mass (2.94 N) for the second calibration point. For calibration using the  $\pm 50$  N range, Vernier recommends using a 1 kg mass (9.8 N) for this second calibration point. Be careful not to exceed the selected range setting during calibration. If you plan to use the Dual-Range Force Sensor in a different orientation (horizontal versus vertical) than calibrated, zero the Force Sensor to account for this. This additional step makes the sensor ready exactly zero when no force is applied.



## Activity 2: Measuring "g"

The force sensor should be hanging vertically. Plug the Vernier Force Sensor into the LabPro. Power up the LabPro and connect it to the PC. Open Logger Pro. If the sensor is not automatically detected, click the 'Lab Pro' button. A picture of the interface box will appear. From the lists of sensors, find the Vernier Force Sensor and drag it to the button that represents the appropriate slot.

Under the *experiment* menu, select *data collection*. When the window opens, change the mode from *time based* to *events with entry*. Change the *entry* column to *mass*, with units of *kg*. Close the window. The graph should now be set up to plot force versus mass. Double-click on the graph. This brings up the graph options window. In the appearance area, unselect "connect points" and select "point protectors."

Close this window and click "collect." A new icon should appear to the right of the "collect" button (which has now turned to a red "stop" button). This new icon is called "keep." With no mass on the force sensor, click "keep." A window will open prompting you to input the mass value. Type "0" (the unit should already be kg). Now place a 10 g mass on the hook, click "keep" again, and input ".01" into the mass field. Continue doing this with a range of masses. When you are finished, click "stop."

Newton's second law states the  $F=mg$ . Therefore the slope of the F versus m graph should be linear, with a value of "g" close to 9.8 N/kg. Apply a linear fit to your F versus m graph to find the value of "g."

## QuickGuide to mass and force

**Mass** is a fundamental concept in physics, roughly corresponding to the intuitive idea of how much matter there is in an object. A scalar quantity, the unit of mass is the kilogram (kg). In everyday usage, mass is more commonly referred to as weight, but in physics and engineering, weight means the strength of the gravitational pull on the object; that is, how heavy it is, measured in units of **force**. More generally, force is something that can cause an object with mass to accelerate. Force is a vector quantity, with both magnitude and direction. An object with mass will accelerate in proportion to the net force acting on it, and in inverse proportion to its mass.

For activities relating to mass and force, see the and the QuickGuide to the Force Sensor, and The QuickGuide to Newton's Laws.

# QuickGuide to Newton's Laws of Motion

## Introduction

Newton's three laws of motion describe the relationship between forces and any motion the object may have. One way to look at Newton's Laws involves evaluating whether forces are balanced or unbalanced. When forces are balanced, there is just as much force acting in one direction as in the opposite direction. For instance, when you are standing still, there is the force of the Earth pulling you down (also known as the force of gravity acting on you) AND there is the force of the floor pushing up on you. These two forces are balanced and you do not change your motion (ie, your velocity does not change) in the vertical or up-down direction. If there are no forces acting to your right or left, then you do not move in the horizontal direction as well. This is the essence of Newton's First Law of Motion.

Newton's First Law, when seen this way, essentially states that an object will keep moving the way it is UNLESS the forces acting on it are unbalanced. So, if the object is stationary, the forces are balanced and the object will remain stationary. Likewise, if the object has constant velocity (not accelerating), it will keep moving with constant velocity because the forces are balanced. Unbalanced forces cause objects to accelerate. If the forces are unbalanced, then the velocity of the object/system will change. That is, the object will accelerate.

Newton's Second Law states that the amount of acceleration is affected by the *sum of the forces* (or net force) acting on the object or system AND the mass of the object or system that is being accelerated. This is the basis for Newton's Second Law of Motion. Newton's Second Law deals with the relationship between cause and effect: what causes an object to change its motion (the effect). Changing the motion of an object means changing velocity over time, or accelerating the object. (We know an object moves because it changes position over a period of time and this is simply velocity.) Since objects will continue moving in the same manner, something has to *cause* an object to change its motion. This cause is a force or a combination of forces (ie, an unbalanced force situation). Two of the factors involved in Newton's second law are therefore acceleration and force. The third factor is mass. A force applied to a massive object produces a different motion than that same force applied to an object with low mass. These three factors, force, acceleration, and mass, can then be used to describe the motion (effect) of an object (or system of objects) that experience an unbalanced force(s) (the cause).

Newton's Third Law of Motion deals with how two objects interact with each other via forces. If one object interacts with a second object (you standing on floor, so you are pushing down on the floor), then the second object will interact with the first object with an equal amount, BUT in the opposite direction (the floor pushes back on you with an equal amount but upward). The key for using the Third Law is to identify the two objects, then look for how one object is interacting with the second object.

## Objectives

- 1) To determine what you need, when you need it, and how to get it.
- 2) To practice determining acceleration using a photogate pulley
- 3) To practice analyzing relationships between two sets of data
- 4) To become familiar with Newton's Laws of Motion.

### Activity 1: Newton's First Law

For a stationary object, determine all the forces acting on the object. Are all the forces acting on the object balanced? Explain. Using a force probe or spring scale, attempt to apply the force necessary to have a block of wood slide along the tabletop with constant velocity. What are your observations? Now attempt to apply the force necessary to have a block of wood slide with constant acceleration (speeding up or slowing down).

### Activity 2: Newton's Second Law

When dealing with forces, one often finds pulleys involved. A pulley is designed to redirect a force. An ideal pulley is able to redirect the force without adding any other effects (friction, rotation, etc.) to the problem.

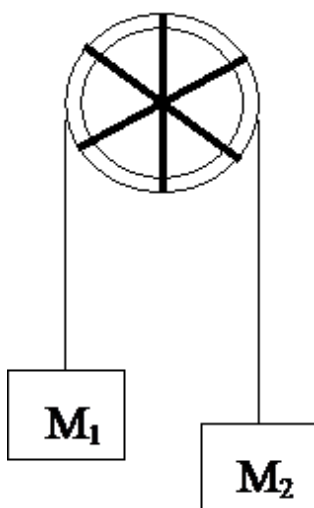

An Atwood system is one that consists of a pulley and two hanging masses,  $M_1$  and  $M_2$ , as shown. Each mass experiences the force of the earth acting on it (otherwise known as the force of gravity OR the weight of the object;  $F = mg$  where  $g = 9.8 \text{ N/kg}$ ). If the forces are equal on the pulley, the pulley remains stationary. However, if the masses are not equal, the gravitational forces are not equal and the pulley system will be unbalanced. In this case, the unbalanced pulley system will accelerate according to Newton's second law.

The Modified Atwood system is similar to the Atwood system, except only one of the masses is hanging. A commonly used Modified Atwood system is shown. In this system,  $M_1$  is on a smooth, flat surface (with or without friction), while  $M_2$  is hanging. The force of gravity still

affects both masses, BUT  $M_1$  is supported by the table so it is balanced and unable to move downward.

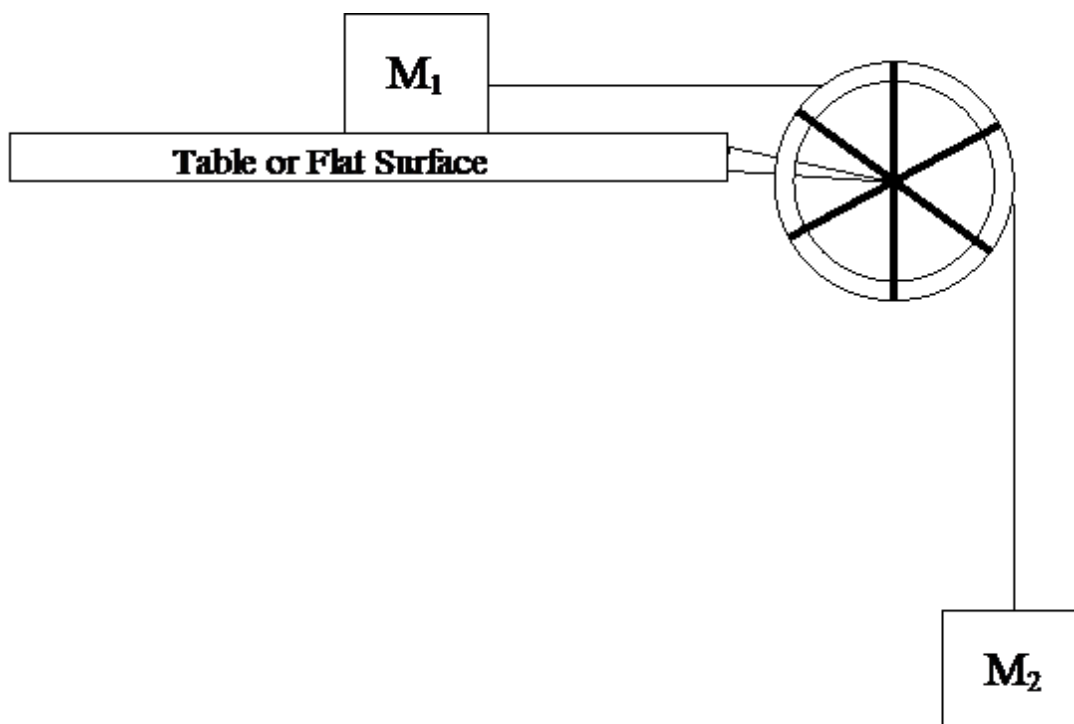

For any of these Atwood-pulley systems, the key is applying Newton's second law for the *entire system*. One way to do this is: what is making the *system* move; what is hindering the system's motion. The difference between these two situations is net force. In the modified Atwood situation,  $M_1$  can move to the right because of  $M_2$ . Therefore, the weight of  $M_2$  is what causes the system to accelerate. In a modified Atwood system, the weight of  $M_2$  is the *net force*. From this, information about the *system's* acceleration can be found (or vice versa).

In this activity you will *graphically* determine the mathematical relationship that is known as Newton's Second Law (the relationship between the net force, the system mass, and the system acceleration) using a modified Atwood system. Now, it is important to note that on a two-axis graph, we can only study two changing variables at a time. That means that one of the three variables has to be turned into a constant. It cannot change while the other two factors are varying.

Before you begin, you will need to familiarize yourself with how to set up the photogate pulley that is on the end of your track and use it to measure acceleration. Please see Activity 2 of the QuickGuide to the Vernier Photogate.

1) Examine the relationship between the net force and the system acceleration. Question: Which factor are you going to have to hold constant in order to look at just the relationship between these two? How are you going to hold this factor constant while you vary the others? Set up this experiment, and acquire the data you need in order to examine the

relationship. NOTE: Please do not make  $M_2$  greater than 50 grams. This could cause damage to our equipment. Once you have acquired the data, plot varying values of net force and system acceleration against each other to determine the relationship between the two.

2) Examine the relationship between the system mass and the system acceleration. Question: Which factor are you going to have to hold constant in order to look at just the relationship between these two? How are you going to hold this factor constant while you vary the others? Set up this experiment, and acquire the data you need in order to examine the relationship. Once you have acquired the data, plot varying values of system mass and system acceleration against each other to determine the relationship between the two.

3) Design a thought experiment in which you would examine the relationship between the net force and the system mass. Question: Which factor would you need to hold constant in order to look at just the relationship between these two? How would you hold this factor constant while varying the others? Describe up this experiment, and how to acquire the data you need in order to examine the relationship.

### **Activity 3: Newton's Third Law**

Two Dual-Range Force Probes (refer back to the QuickGuide to the Vernier Force Sensor) are needed for this activity. Make sure to calibrate each force probe before starting and before each new activity. Click the 'Lab Pro' button. A picture of the interface box will appear. Select one of the force sensors and choose "reverse direction." This way you will see two diverging lines when the force sensors are opposing each other.

Attach one force probe to a cart or block and use the other force probe to push or pull it. Be careful to watch the cable! What happens if you change the mass? Push and pull the two probes against each other. From the graphical results, verify Newton's third law for yourself.

# QuickGuide to Newton's Second Law

## Introduction

Newton's second law deals with the relationship between cause and effect: what causes an object to change its motion (the effect). Changing the motion of an object means changing velocity over time, or accelerating the object. (We know an object moves because it changes position over a period of time and this is simply velocity.) Since objects will continue moving in the same manner, something has to **cause** an object to change its motion. This cause is a force or a combination of forces (ie, an unbalanced force situation).

Two of the factors involved in Newton's second law are therefore acceleration and force. However, there is a third factor: mass. A force applied to a massive object produces a different motion than that same force applied to an object with low mass. These three factors, force, acceleration, and mass, can then be used to describe the motion (effect) of an object (or system of objects) that experience an unbalanced force(s) (the cause).

## Objectives

To determine and verify the mathematical relationship for Newton's Second Law.

### Activity 1: Weight

A useful force to use in the lab setting is the weight of an object. Weight is the effect of the attraction between one mass and another. On Earth, the mass of our planet has a huge effect on every mass on (and masses off) the planet. This is why when we stand on the scale, we can record our weight: it is the effect of the pull of the Earth on each person or object. This pull from the Earth is due to the force of gravity between the mass of the Earth and the mass of the object. So,  $\text{Weight} = F_{\text{gravity}} = F_{\text{Earth on object}}$ .

To determine the weight ( $F_g$ ) of an object, you need to know two things: its mass and the Earth's effect on it. An object's mass can be determined by using a mass balance, while the Earth's effect on an object is a constant for the planet Earth. This constant is "g": the gravitational field constant for Earth. (Other objects, especially massive ones, have different values for g than the one for Earth.) The simplest way to determine "g" is to measure the mass of an object, then measure the force that the Earth pulls down on the object, ie,  $F_g = \text{weight of the object}$ .

Determine "g" using a force probe and a pan balance.

### Activity 2: Newton's Second Law

Graphically determine the mathematical relationship that is known as Newton's Second Law (the relationship between force, mass and acceleration).

### Hints and Suggestions

- When experimenting, it is important to only examine two factors at a time. If there are more than two factors, make sure to keep all the other factors constant. This way, you can determine the relationship between two of the factors directly. (Other factors can either be deduced from the data analysis OR from additional experiments.) Pick the factors you think you can keep constant. If those factors are difficult to deal with, change the experiment.
- Keep in mind that it may be easier to look at an unbalanced force situation for an entire *system* than it is for a single object.
- There are multiple ways to measure the change of an object's motion.
- There are multiple ways to create an unbalanced force situation (Atwood systems, free fall, etc.).
- There are multiple ways to determine the value of the unbalanced force acting on an object or a *system*.
- There are multiple ways to determine an object's mass, although only one is routinely used.

## Quick Guide to Pulleys and Atwood Systems

### Introduction

When dealing with forces, one often finds pulleys involved. A pulley is designed to redirect a force (see Activities below). An ideal pulley is able to redirect the force without adding any other effects (friction, rotation, etc.) to the problem.

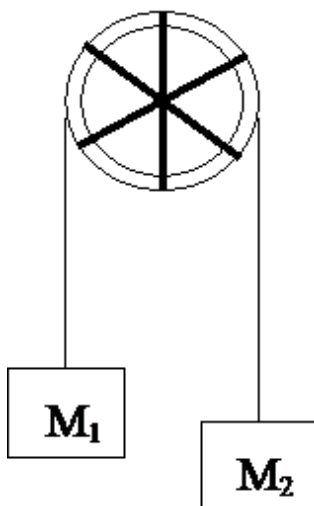

An Atwood system is one that consists of a pulley and two hanging masses,  $M_1$  and  $M_2$ , as shown. Each mass experiences the force of the earth acting on it (otherwise known as the force of gravity OR the weight of the object,  $F_g = mg$  where  $g = 9.8 \text{ N/kg}$ ). If the forces are equal on the pulley, the pulley remains stationary. However, if the masses are not equal, the gravitational forces are not equal and the pulley system will be unbalanced. In this case, the unbalanced pulley system will accelerate according to Newton's second law.

The Modified Atwood system is similar to the Atwood system, except only one of the masses is hanging. A commonly used Modified Atwood system is shown. In this system,  $M_1$  is on a smooth, flat surface (with or without friction), while  $M_2$  is hanging.  $F_g$  still affects both masses, BUT  $M_1$  is supported by the table so it is balanced and unable to move downward. However,  $M_1$  can move to the right because of  $M_2$ .

For any of these Atwood-pulley systems, the key is drawing the force diagrams for *each* object, then applying Newton's second law. It is also useful to apply Newton's second law for the *entire system*. One way to do this is: what is making the *system* move; what is hindering the system's motion. The difference between these two situations is net force. From this, information about the *system's* acceleration can be found (or vice versa).



**OBJECTIVES**

By the end of the activities, you should be able to:

- Be comfortable dealing with pulley situations;
- Draw force diagrams for the system AND for each object;
- Know how to deal with the tension in the string connecting the two objects;
- Determine the acceleration of the system and of each object;
- Determine the net force for each object and for the system.

**Activity 1**

If a force probe is attached directly to an object that is dragged along a smooth, flat surface, compare the reading on the force probe with the force experienced by the object.

The same force probe and object are used. Now, a string is used to connect the force probe to the object. Compare the reading on the force probe with the force experienced by the object. What is the role of the string? What force, if any, does the string experience?

When certain objects, like strings or rope, are pulled, they are under tension (similar to muscles in the body). Tension is the name of this pulling force on strings, ropes, or muscles.

The same force probe, object, and string are used. Now, the string goes around a pulley, like in the Modified Atwood set-up above. Compare the reading on the force probe with the force experienced by the object. What force, if any, does the string experience?

**Activity 2**

Replace the object lying on a smooth, flat surface with the force probe. The probe should be able to slide on the flat surface without crashing to the floor. Set up the Modified Atwood system where  $M_2$  is a mass hanger with some mass hanging on it.

While holding the force probe in place, compare the force reading with  $F_g$  for the hanging mass.

While allowing the force probe to slide (without crashing into anything or onto the floor), compare the force reading with  $F_g$  for the hanging mass.

Discuss the similarities and differences between the two situations.

**Activity 3**

Compare the accelerations for the two situations below:

Situation 1:  $M_1 = M_2 = 1 \text{ kg}$

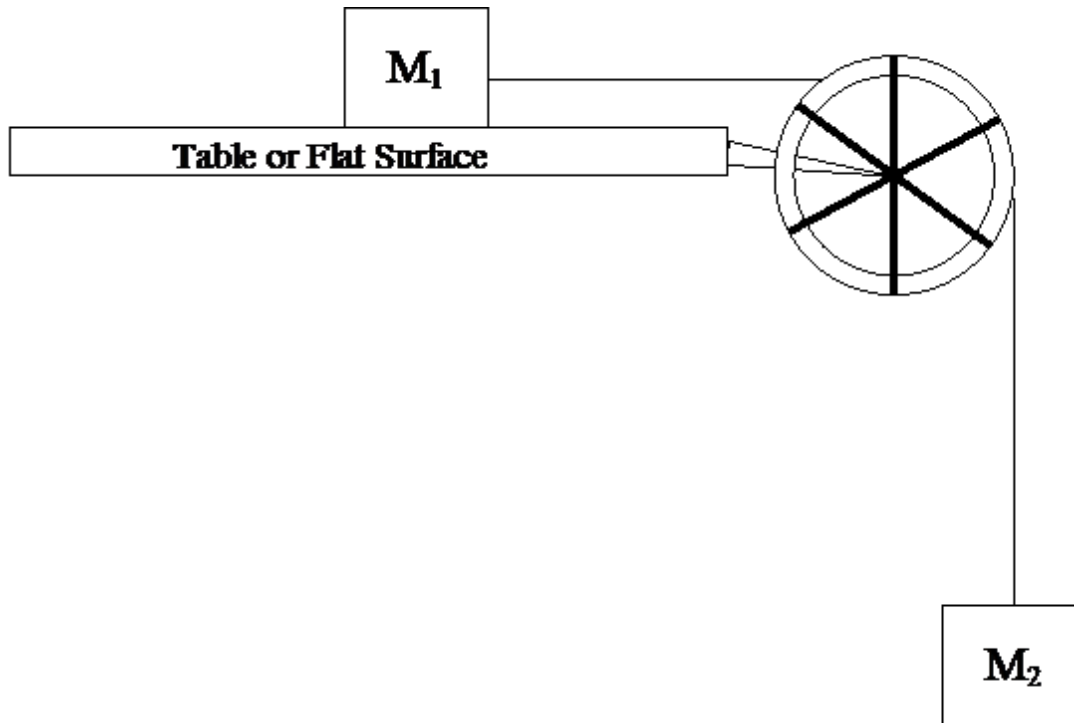

Situation 2:  $F_{\text{pull}} = 9.8 \text{ N}$

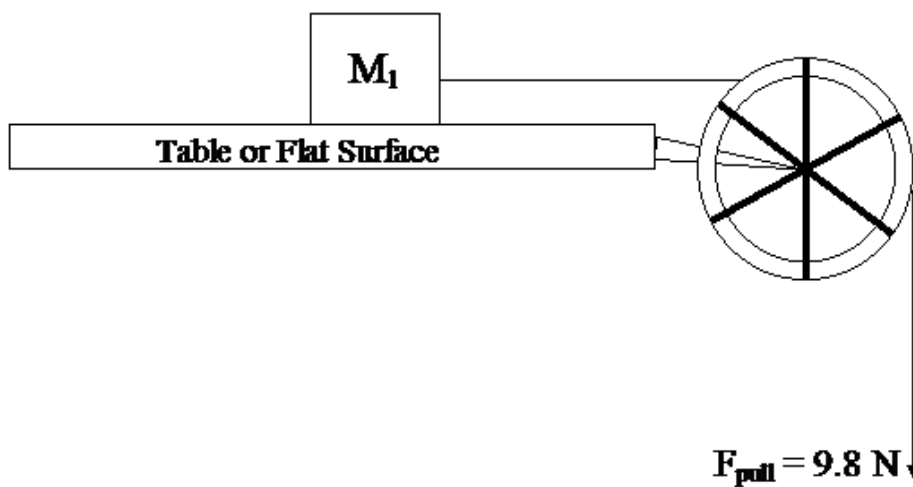

**Hint:** Are the two *systems* completely identical?

## QuickGuide to the Vernier Accelerometer



The Low-g (5g) accelerometer is used for studying one-dimensional motion such as that of a car (real and toy), elevator, pendulum bob, or amusement park ride. Its range is  $\pm 50 \text{ m/s}^2$ . The High-g (25-g) accelerometer is used for studying one-dimensional collisions or any motion with larger accelerations, and has a range of  $\pm 250 \text{ m/s}^2$ .

The Low-g Accelerometer measures acceleration along the line marked by the arrow on the label. Accelerations are normally measured in either meters per second per second ( $\text{m/s}^2$ ) or g's. Remember that the g-factor is not a force. Instead, g-factor can be used as a simplified label for Normal Force per Unit Mass. The g-factor is then 1 for an object sitting at rest on a table, zero in free fall, etc. The g-factor is dimensionless. If the Normal Force is a vector, then so is the g-factor. g-factor is completely optional—it is just a shortcut to avoid a long name. Another thing to watch out for is the pitfall of calling something an acceleration when it is not a kinematic acceleration. For example, an “acceleration” of  $9.8 \text{ m/s}^2$  for an object that remains at rest is clearly a problematic interpretation, yet that’s what the accelerometer reads. You can correct the Accelerometer reading to get a true acceleration by adding the component of the gravitational acceleration field along the direction of the sensor arrow. For example, if the axis of the accelerometer is pointing upward, then the gravitational component is  $-9.8 \text{ m/s}^2$ . The Accelerometer reads  $9.8 \text{ m/s}^2$  when the arrow is upward and the device is at rest. By adding  $-9.8 \text{ m/s}^2$ , we get zero, which is the correct kinematic acceleration. If the arrow is horizontal, then the reading is zero, but the gravitational component is zero, and we still have zero for the true acceleration. This Accelerometer will measure accelerations in the range of  $-5 \text{ g}$  ( $-49 \text{ m/s}^2$ ) to  $+5 \text{ g}$  ( $+49 \text{ m/s}^2$ ). This is a range of accelerations which a human body could experience without damage. Many collisions will produce much larger accelerations. In fact, dropping the Accelerometer on a hard surface from even a few centimeters can produce accelerations of a hundred g's. The Low-g Accelerometer will not be damaged by accelerations up to 1000 g's.

### Activity 1: Calibrating the Accelerometer

Plug the Accelerometer into the LabPro. Power up the LabPro and connect it to the PC. Open Logger Pro. If the sensor is not automatically detected, click the ‘Lab Pro’ button. A picture of the interface box will appear. From the lists of sensors, find the Accelerometer and drag it to the button that represents the appropriate slot.

While watching the live readout of the Accelerometer, notice that the values will change as its orientation is tilted from horizontal to vertical. In this way, the Accelerometer may also be

used as an "Inclinometer" to measure the tilt of an object, allowing you to measure angles to the nearest degree. You can use this to provide an easy way to calibrate the Accelerometer. To calibrate the sensor for measuring acceleration in the horizontal direction, position the Accelerometer with the arrows pointing down for the first calibration point. Define this as  $-9.8 \text{ m/s}^2$  or  $-1 \text{ g}$ . Rotate the Accelerometer so the arrows point up and use the reading for the second calibration point. Define this as  $+9.8 \text{ m/s}^2$  or  $+1 \text{ g}$ . The Accelerometer will then read 0 with no acceleration when held horizontally.

### **Activity 2: Measuring acceleration**

Connect the Accelerometer to the LabPro and start Logger Pro. Identify the sensor and click 'collect.' Holding the Accelerometer, jump up and down a few times. What information does the Accelerometer give about your movements? Try attaching the Accelerometer to a fan cart or a cart on an incline. Make sure the arrow is in the direction of the acceleration, and zero the Accelerometer. Click 'collect,' and acquire data from the motion of the cart. Be sure to catch the cart -- don't let it run out of track! Click 'stop,' then click the autoscale button. What is the shape of the position versus time graph? What is the shape of the velocity versus time graph? Highlight the data in the acceleration versus time graph. Go to *analyze* → *statistics*. What is the mean (average) acceleration? How does this compare to the slope of the velocity versus time graph?

# QuickGuide to Acceleration

## Introduction

From the “Not-so-quick Guide to Motion,” both speed and velocity require a change in distance over a change in time. However, speed does not rely on direction while velocity does. This distinction between speed and velocity is an important concept to keep in mind when dealing with the motion of objects, especially when velocity is changing with time.

Most people are comfortable explaining “acceleration” as a change in speed, that is, speeding up or slowing down. They experience this acceleration in automobiles while moving from a stop to some speed (ie, the speed limit) or while stopping, especially when stopping quickly. However, they also experience an acceleration when making a turn. This is because of the change in direction of the automobile. This means that acceleration is any change in the velocity (speed and/or direction) over time.

There are multiple ways to determine the acceleration of an object. Most of the experimental methods involve measuring the position of the object at each moment in time. The velocity of the object at each moment in time can then be determined. From this information, the acceleration of the object can be determined using different mathematical analysis techniques that are available on LoggerPro or using Excel.

## Objectives

1. By the end of this lab your should be comfortable determining acceleration using position, velocity, or acceleration versus time graphs.
2. This lab should give you practice using a video analysis software to analyze the motion of an object.
3. This lab should help you understand the velocity and acceleration of an object in free fall.

## Prelab Questions/Activities.

1. Do the Video Analysis tutorial located in the Tutorials folder of Logger Pro. The procedure, observations, and comments should be recorded in your lab notebook.
2. For a ball tossed in a two dimensional plane, predict the position, velocity, and acceleration versus time graphs in both the horizontal and vertical directions (a total of 6 graphs). Sketch these graphs in your notebook.

## Activity 1: Behr Free Fall with Carbon Paper

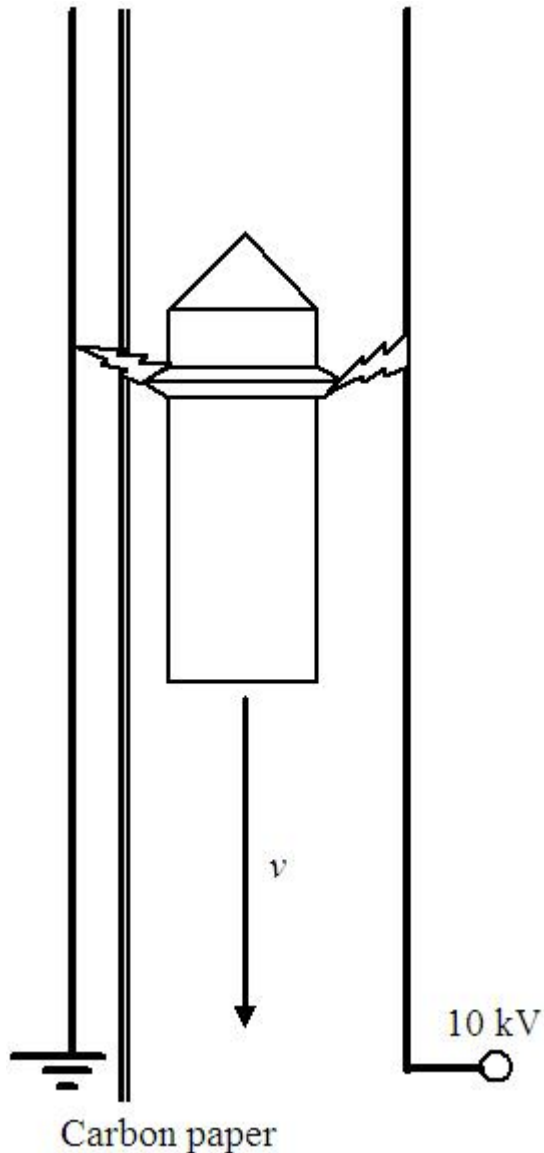

**CAUTION: HIGH VOLTAGE!**

Hold the drop shuttle of the Behr Free Fall apparatus up to the electromagnet at the top of the apparatus, and turn on the power supply to the electromagnet. When the electromagnet is connected, turn the power supply off, and see that the shuttle drops cleanly into the foam catcher below. If it doesn't, you will have to adjust the feet until the apparatus is vertical. When you are ready to make a measurement, slide a ribbon of carbon paper between the grounded wire and the high voltage knife edge. Make sure that the paper is taut! Turn on the high voltage supply and stand back. Press the thumb-switch to make sure that the supply is working properly. You will see sparks where the shuttle is hanging. While one person is activating the high-voltage power supply is pressing the spark button, another person should release the electromagnet. Turn off the high voltage power supply and examine the carbon paper. A series of equally timed high potential sparks which penetrate the carbon paper 60 times each second at the precise location of the shuttle ring.

Open Logger Pro and make a distance versus time graph of this data that you can use to determine 'g'. It is important to note that Logger Pro does NOT understand fractions. You have to enter all values in decimal notation. Make enough careful distance measurements for a good graph; you don't have to record every single set of points! Record your uncertainty. Choose an appropriate curve fit and use the parameters of the equation to determine 'g'. Compare this to the accepted value of 'g' using percent error. Print this graph.

Using the same data, create a velocity versus time graph that plots how the velocity changes at each time interval. Choose an appropriate curve fit and use the parameters of the equation to determine 'g'. Print this graph.

### **Activity 2: Measuring acceleration in one dimension using Logger Pro**

Set up an experiment where a motion detector looks at a cart rolling down an incline. Using Logger Pro, generate a graph of distance versus time, velocity versus time, and acceleration versus time. For each of these graphs, use the "curve fit," "linear fit," or "statistics" functions under the "analyze" menu to determine the acceleration of the cart while it is rolling down the incline. Print this graph. Compare these three values of acceleration using percent difference.

### **Activity 3: Using video analysis for motion in two dimensions**

Connect a camera to the computer and insert the driver installation disk. Choose English when prompted for a language. When the installation window opens, select the Software Installation option, then select Drivers. Select USB Cameras and load the driver. After the driver has been loaded, close the installation window. Open Logger Pro. Under the "Insert" menu, select "Video Capture." Choose a resolution and make sure that the camera is working.

In order to reduce the blur of a moving object, you will need to adjust the exposure. With the Video Capture window open, click "Options." In the options window, select "Camera Settings." The default exposure is set to "Auto," so deselect that option then choose an exposure of 1/200 sec.

You will toss a ball into the air to a partner while a third person videos. Adjust the camera so that it is an appropriate distance from the toss, then focus the lens by turning it. The camera should be perpendicular to the plane of the toss, and the entire toss should be caught on video. Make sure that the camera is level, so that you can use the default coordinate plane! Place a meter stick in the same plane as the tossed ball to be used to set the scale for the video analysis. When all is ready, the person controlling the computer should click "Start Capture." While the video is being created toss the ball. Stop video capture when the shuttle stops, and step through the video to make sure that the motion has been recorded.

Using what you learned in Activity 1, analyze the motion of the ball in two dimensions. Create position and velocity versus time graphs for the  $y$  (vertical) direction, and use these graphs to determine the vertical acceleration. Print these graphs. Create position and velocity

versus time graphs for the  $x$  (horizontal) direction, and use these graphs to determine the horizontal acceleration. Print these graphs.

#### **Activity 4: Analyzing the data (PHY 1150 only)**

For data that is normally distributed, around 68% of the data lie within one standard deviation of the mean, and around 95% of the data lie within two standard deviations of the mean. Click [here](#) for more information and help with calculating mean and standard deviation. Make a table of data for the entire class that includes both values of 'g' from Activity 3. Determine the mean and standard deviation for each. Compare each to the accepted value of 'g' using percent error. How do your individual calculations of 'g' compare with the class data? Are you within one standard deviation of the mean? Use this information to discuss the reliability and accuracy of each method of analysis.

For more information on activities relating to acceleration, refer to the Not-so-quick Guide to Motion, the Quickguide to the Accelerometer, and the QuickGuide to the Photogate.

#### **Postlab Questions**

1. Discuss how your graphs compared to your predictions.
2. Using the horizontal graphs from Activity 3, describe the relationship between position and velocity. What is the acceleration? Is it constant?
3. Using the horizontal graphs from Activity 3, describe the relationship between position and velocity. What is the acceleration? Is it constant?
4. Average the values of 'g' from Activity 1 (from the position and velocity graphs) and compare this to the accepted value of 'g' using percent error.
5. Average the values of 'g' from Activity 3 (from the position and velocity graphs) and compare this to the accepted value of 'g' using percent error.



## Quickguide to the Vernier Photogate



The Vernier Photogate works both as a traditional photogate for objects passing between the gate arms, and as a laser gate for objects passing outside of the gate. When an object enters the gate, a timing mechanism is triggered and time is counted until the gate is cleared. The gate has an input port so multiple gates can be connected in a daisy-chain configuration with up to four gates going to a single interface channel. Photogates can be used to study free fall, air track collisions, pendulum periods, the speed of a rolling object, and many other things. The Vernier Photogate includes an accessory rod for mounting to a common ring stand.

### Activity 1: Through the wickets

Measure the diameter of a ball using Vernier calipers. See this page for information on how to use the calipers. Carefully position a Vernier Photogate so that the ball rolls between the arms of the photogate, with the diameter of the ball passing directly through the beam of the photodiode. If it is too high or too low, the photogate will not be closed for the full length of time. Plug the Vernier Photogate into the LabPro. Power up the LabPro and connect it to the PC. Open Logger Pro. If the Vernier Photogate is not automatically detected, click the 'Lab Pro' button. A picture of the interface box will appear. From the lists of sensors, find the Vernier Photogate and drag it to the button that represents the appropriate slot. Close this window and click "collect." Roll the ball through the photogate arms, then click 'stop.' The data window will display the time that the photogate closed, and the time that it reopened. Knowing the diameter of the ball and the length of time the gate was closed, try to determine the speed of the ball.

### Activity 2: Modified Atwood (measuring acceleration)

Set up the Logger Pro window to show a graphs of distance, velocity, and acceleration versus time. Connect the photogate to the Lab Pro. If it doesn't auto detect, click the Lab Pro icon and drag a photogate to the appropriate port. Under the sensor photogate setup menu, choose "motion timing." Then select *Set Distance and Length*. From the resulting menu, choose "10 spoke pulley (outer edge)." Exit the sensor setup menu. Attach a photogate and a ten-spoke pulley to one end of a track. Attach a string to a cart. Drape the string over the pulley and attach the other end to a small mass. Pull the cart back so that the mass is pulled up to the pulley. Click 'collect,' and release the cart. Be sure to catch the cart -- don't let it run out of track! Click 'stop,' then click the autoscale button. What is the shape of the position versus time graph? What is the shape of the velocity versus time graph? Highlight the portion of the graph where the cart was in motion. Fit the position versus time graph with a quadratic curve

fit, or the velocity versus time graph with a linear curve fit, in order to determine the acceleration.

### **Activity 3: The rolling fence (measuring acceleration)**

Set up the Logger Pro window to show a graphs of distance, velocity, and acceleration versus time. Under the sensor setup menu, choose "motion timing." Then select *Set Distance and Length*. From the resulting menu, choose "Picket Fence." Attach one of the picket fences to the side of a cart so that it passes through the arms of a photogate. Place the cart on a track at a slight incline, with the photogate halfway down the track. Click 'collect,' and release the cart. Be sure to catch the cart -- don't let it run out of track! Click 'stop,' then click the autoscale button. What is the shape of the position versus time graph? What is the shape of the velocity versus time graph? Highlight the data in the acceleration versus time graph. Go to *analyze*→*statistics*. What is the mean (average) acceleration? How does this compare to the slope of the velocity versus time graph?

### **Activity 4: Free falling**

Set up the Logger Pro window to show a graphs of distance, velocity, and acceleration versus time. Under the sensor setup menu, choose "motion timing." Then select *Set Distance and Length*. From the resulting menu, choose "Picket Fence." Click 'collect,' and drop a plastic picket fence through the arms of the photogate. Be sure to catch the fence -- don't let it hit the floor! Click 'stop,' then click the autoscale button. What is the shape of the position versus time graph? What is the shape of the velocity versus time graph? Highlight the data in the acceleration versus time graph. Go to *analyze*→*statistics*. What is the mean (average) acceleration? How does this compare to the slope of the velocity versus time graph?

# QuickGuide to Projectile Motion

## STATIC ELECTRICITY

### Introduction

A projectile is an object upon which the only force acting is gravity. There are a variety of examples of projectiles. An object dropped from rest is a projectile (provided that the influence of air resistance is negligible). An object which is thrown vertically upward is also a projectile (provided that the influence of air resistance is negligible). And an object is which thrown upward at an angle to the horizontal is also a projectile (provided that the influence of air resistance is negligible). A projectile is any object which once *projected* or dropped continues in motion by its own inertia and is influenced only by the downward force of gravity.

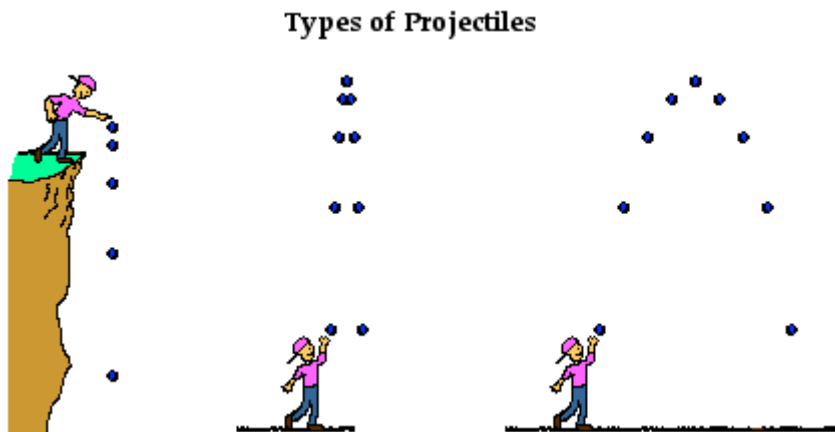

By definition, a projectile has only one force acting upon it - the force of gravity. If there was any other force acting upon an object, then that object would not be a projectile. Thus, the free-body diagram of a projectile (see the figure) would show a single force acting downwards and labeled force of gravity. Regardless of whether a projectile is moving downwards, upwards, upwards and rightwards, or downwards and leftwards, the free-body diagram of the projectile is still as depicted in the diagram at the right. By definition, a projectile is any object upon which the only force is gravity.

**Free-Body Diagram  
of a Projectile**



Many students have difficulty with the concept that the only force acting upon an upward moving projectile is gravity. Their conception of motion prompts them to think that if an object is moving upward, then there *must* be an upward force. And if an object is moving upward and rightward, there *must* be both an upward and rightward force. Their belief is that forces cause motion; and if there is an upward motion then there must be an upward force. They reason, "How in the world can an object be moving upward if the only force acting upon it is gravity?" Such students do not *believe* in Newtonian physics (or at least do not believe strongly in Newtonian physics). Newton's laws suggest that forces are only required

to cause an acceleration (not a motion). Newton's laws stood in direct opposition to the common misconception that a force is required to keep an object in motion. This idea is simply not true! A force is not required to keep an object in motion. A force is only required to maintain an acceleration. And in the case of a projectile that is moving upward, there is a downward force and a downward acceleration. That is, the object is moving upward and slowing down.

To further ponder this concept of the downward force and a downward acceleration for a projectile, consider a cannonball shot horizontally from a very high cliff at a high speed. And suppose for a moment that the *gravity switch* could be *turned off* such that the cannonball would travel in the absence of gravity? What would the motion of such a cannonball be like? How could its motion be described? According to Newton's first law of motion, such a cannonball would continue in motion in a straight line at constant speed. If not acted upon by an unbalanced force, "an object in motion will ...". This is Newton's law of inertia.

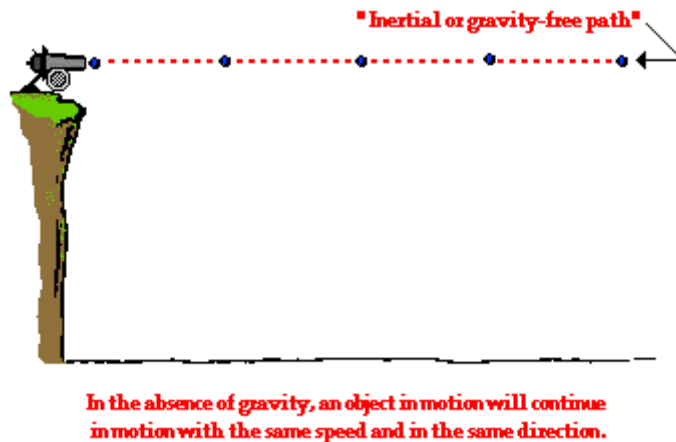

Now suppose that the *gravity switch* is turned on and that the cannonball is projected horizontally from the top of the same cliff. What effect will gravity have upon the motion of the cannonball? Will gravity affect the cannonball's horizontal motion? Will the cannonball travel a greater (or shorter) horizontal distance due to the influence of gravity? The answer to both of these questions is "No!" Gravity will act downwards upon the cannonball to affect its vertical motion. Gravity causes a vertical acceleration. The ball will drop vertically below its otherwise straight-line, inertial path. Gravity is the downward force upon a projectile which influences its vertical motion and causes the parabolic trajectory which is characteristic of projectiles.

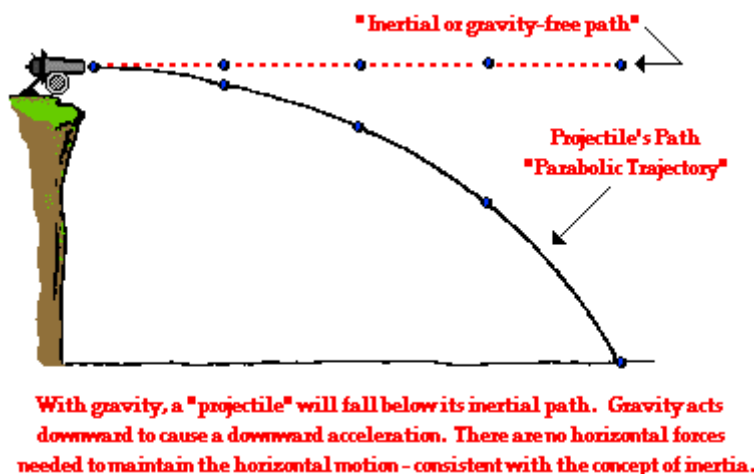

A projectile is an object upon which the only force is gravity. Gravity acts to influence the vertical motion of the projectile, thus causing a vertical acceleration. The horizontal motion of the projectile is the result of the tendency of any object in motion to remain in motion at constant velocity. Due to the absence of horizontal forces, a projectile remains in motion with a constant horizontal velocity. Horizontal forces are not required to keep a projectile moving horizontally. The only force acting upon a projectile is gravity!

source: <http://www.physicsclassroom.com/Class/vectors/u3l2a.cfm>

## MATERIALS

- Ramp and ball
- Vernier LabPro and photogate
- Meter stick
- Video Camera and Logger Pro

## ACTIVITIES

### Activity 1: Predicting initial velocity

A ball rolls down a ramp that is sitting on a table top and leaves the end of the ramp parallel to the ground. Its path then follows a parabolic trajectory until it strikes the ground. By determining the range and the height of the fall, you should be able to calculate the initial velocity of the ball.

For greater accuracy, make several determinations of the range, each time releasing the ball from the same point on the ramp. Make a careful calculation of how high the release point is above the end of the ramp where the ball comes off horizontally. You will use this information in a later lab assignment.

Once you have calculated the initial velocity, use the Vernier Photogate to determine the initial velocity experimentally. This can be done by setting up Activity 1 in the QuickGuide to the Photogate. Perform this several times to find an average velocity. Compare the value

of the velocity you calculated to the velocity measured by the photogate using percent difference.

### Activity 2: Predicting the motion maps

On a sheet of graph paper, use the values you have measured above to sketch the velocity versus time (both horizontal and vertical) on the same graph. You should have two lines on one graph. Label each, and give your graph a title. This graph should be scaled correctly, so plan ahead when choosing a scale.

Next graph the displacement versus time (both horizontal and vertical) on a different graph. Again, you should have two lines on the same graph. Label each, and give your graph a title. This graph should be scaled correctly, so plan ahead when choosing a scale.

What should the values of acceleration be (both vertical and horizontal)?

### Activity 3: Video analysis of projectile motion

Connect your camera to Logger Pro and make a video of the ball falling rolling off the ramp. Using video analysis, plot the trajectory of the ball.

Plot velocity versus time for both the horizontal and vertical direction on the same graph. You should see two lines. Predict what line equation would best model these lines, and try a fit to each line. Use the curve fit function to determine the vertical and horizontal acceleration. Label each line (you can use a legend), correctly title your graphs, and label each axis. Print this graph.

Plot position versus time for both the horizontal and vertical direction on the same graph. You should have two lines. Predict what line equation would best model these lines, and try a fit to each line. Use the curve fit function to determine the vertical acceleration and the horizontal velocity. Label each line (you can use a legend), correctly title your graphs, and label each axis. Print this graph.

## **POSTLAB QUESTIONS**

- 1). How do your predictions of the motion in activity two compare to the results of the video analysis? Discuss each graph as well as the values of acceleration you determined.
- 2) Using percent error, compare the vertical acceleration you got from the video analysis graph to the accepted value.
- 3) Using percent difference, compare the horizontal velocity got from the video analysis graph to the value you calculated in Activity 1.
- 4) A package falls off a truck that is moving at 30 m/s. *Neglecting air resistance*, what is the *horizontal* speed of the package just before it hits the ground?
- 5) It takes 6 seconds for a stone to fall to the bottom of a mine shaft. How deep is the shaft?

# PHY 1103 Pre-Lab Assignment: Masses and Springs

## OBJECTIVES

By the end of the activities, students should be able to:

- Explain the distribution and transfer of different types of energy (kinetic, elastic potential, gravitational potential, and thermal).
- Explain the concept of Conservation of Energy.

## RESOURCES

Computer with internet access

Mass and Spring simulation: under the Motion category located here:

[http://phet.colorado.edu/simulations/sims.php?sim=Masses\\_and\\_Springs](http://phet.colorado.edu/simulations/sims.php?sim=Masses_and_Springs)

## ACTIVITIES

### Part 1: No Friction

Adjust the settings of the simulation set to “none” for friction, “Earth,” and select the number of a spring to view the energy diagram (sorry, only one diagram can be viewed at a time).

Place masses on the spring, set it in motion, and observe the distribution of energy.

Adjust the “softness” of spring 3 and observe what happens as the mass oscillates (repeats its motion). As the spring becomes more “soft,” what happens to the stretch (how much the spring can be displaced) for a given force?

### Part 2: With Friction

Adjust the settings of the simulation to a non-zero value for friction, “Earth,” and select the number of a spring to view the energy diagram. Repeat above activities. How does friction affect the motion of the mass and spring compared to a frictionless spring? How does friction affect the energy distribution?

### Part 3: More fun and games

Adjust the setting so that “g” is different. How does this affect the motion of the mass and spring? What forms of energy are directly affected by changing the value for “g”?

## WHAT TO TURN IN

Write a *one page (maximum)* report describing your observations from the simulation. In particular, explain what happens to the energy distribution as the mass oscillates with the spring, with and without friction. Make sure to include a brief explanation as to how the Conservation of Energy applies to this simulation.

---

**Questions to consider before the lab activities, but are not required for the report (but may be useful when putting the pieces together to write the report).**

- What force is causing the spring to stretch in the first place? How would you experimentally determine the force causing the spring to stretch?
- How would you experimentally determine the “softness” of the spring (known as the spring constant =  $k$ )?
- How would you explain Elastic Potential Energy (EPE) to someone? What causes it? What are some of the factors affecting it? How would you measure EPE?
- How would you explain Gravitational Potential Energy (GPE) to someone? What causes it? What are some of the factors affecting it? How would you measure GPE?
- How would you explain Kinetic Energy (KE) to someone? What causes it? What are some of the factors affecting it? How would you measure KE?
- How would you explain Thermal Energy (TE) to someone? What causes it? What are some of the factors affecting it? How would you measure TE?
- For the mass-spring system, where is EPE a maximum? A minimum? Zero?
- For the mass-spring system, where is GPE a maximum? A minimum? Zero?
- For the mass-spring system, where is KE a maximum? A minimum? Zero?
- For the mass-spring system, where is TE a maximum? A minimum? Zero?

For the mass-spring system, what factors affected the total energy of the system? In particular, what could you do to increase the total energy of the system?



## Quick Guide to Springs and Spring Energy

### Introduction

A spring is usually a coiled piece of metal or plastic that has the property of stretching when pulled. If the spring is "elastic," then it will return to its original length/shape when the pulling force is removed. (Depending on the coiling, some springs can also be compressed.) For many springs, the more you try to stretch the spring, the more force is required. This is unlike many of the forces encountered in most of introductory physics. For instance, to lift a ball off the floor with constant velocity, you need to supply a force equal to the ball's weight. (Make sure you can explain why this is so.)

Since the ball's weight is constant, the lifting force is constant. This also means that the work done in lifting the ball a distance,  $h$ , is also constant. In this case, the work due to lifting gives the ball gravitational potential energy ( $PE_{\text{grav}}$ ) found simply by  $PE_{\text{grav}} = mgh$ . If you want to double  $PE_{\text{grav}}$ , the height you lift the ball has to be doubled.

In contrast to the ball, moving a spring a distance,  $x$  (measured from its unstretched position) requires a non-constant force: the more you stretch/compress a spring, the more force it requires. For elastic springs, the relationship between the applied force and the distance the spring moves is called Hooke's Law. This relationship also depends on a property of the spring. The more "stiff" a spring is, the more difficult it is to stretch or compress it. The "stiffness" of a spring is more commonly referred to as the 'spring constant,'  $k$ .

Hooke's Law:  $F = -kx$

One advantage of needing a non-constant force to stretch/compress a spring is that as the spring is stretched/compressed, more and more work is done. This has the benefit of storing energy in that spring until it is released. Anyone who has played with spring-loaded toys or gadgets understands that when you change the spring's length by a little bit, then let go, something happens. Change the length a little bit more, let go, a lot more can happen. This is because the work done while changing the spring's length has gone into potential energy, in this case, **elastic potential energy** ( $PE_{\text{elastic}}$ ). For elastic springs (ones that obey Hooke's law),  $PE_{\text{elastic}} = \frac{1}{2} kx^2$ , where  $k$  is the spring constant for the spring and  $x$  is the distance the spring has stretched from its equilibrium position. The **elastic kinetic energy** of a vertically hanging spring is found using the following equation:  $KE_{\text{elastic}} = \frac{1}{2} mv^2$ , where  $m$  is the hooked mass plus one third of the mass of the spring (called the **effective mass** of the spring). The total mechanical energy,  $ME_{\text{elastic}}$ , is equal to the sum of  $KE_{\text{elastic}}$  and  $PE_{\text{elastic}}$ .

### Objectives

Verify Hooke's Law

Examine conservation of energy for a mass-spring system

### Materials

Lab Pro and computer

Motion detector  
 Force Probe  
 Helical spring  
 Table clamp, rod, and spring support  
 Masses

### **Prelab Activity: Virtual Springs**

Follow this link for an interactive assignment on masses and springs.

### **Lab Activities**

#### **Activity 1: An Oscillating Spring**

A mass placed on the spring will be set into oscillatory motion (motion between two points in a rhythmic manner). Attach the spring to a force probe and measure its motion with a motion detector. Refer to Quick Guides for the Force Probe, Motion Detector, and Graphing with Logger Pro if needed. Be sure to calibrate and zero the force probe before beginning this experiment! Make sure to zero the force probe and the motion detector while the mass is at rest in its equilibrium position. This provides a useful reference point for the motion graphs. Graph the force, position and velocity of the spring as a function of time. Keep this data up on your screen -- you will need it for the other activities.

#### **Questions:**

1. What is the actual location of the mass when the velocity is at its most positive value?
2. What is the actual location of the mass when the velocity is zero?
3. What is the actual location of the mass when velocity is at its most negative?
4. When does the spring have the maximum elastic kinetic energy? Identify this point on the graph of position versus time.
5. When does it have the maximum elastic potential energy? Identify this point on the graph of position versus time.

#### **Activity 2: Finding $k$ Using Hooke's Law**

**Prediction:** Given the Hooke's Law equation above, predict the graphical relationship between force and position. How would you orient the axes in order to generate a slope that is equal to the spring constant ( $k$ )? Sketch your prediction before continuing.

Using the data generated in Activity 1, graphically show this relationship.

#### **Questions:**

6. How do you know that Hooke's Law is "verified" from your data?
7. How is the spring constant determined for your spring?
8. If you received a stiffer spring, how would your data change?
9. What would happen if you were to link two springs end-to-end (would it become more "stiff")?
10. What would happen if you were to cut a spring in half? (**Please do not do this as the springs used in lab are pretty expensive.**)

### Activity 3: Finding k Using Simple Harmonic Motion

For an oscillating system,  $F = ma = -kx$ . The acceleration of the oscillating system is  $-\omega^2x$ , where the angular frequency,  $\omega$ , is equal to  $= 2\pi f$ , and  $m$  is the effective mass. From your graph, determine the angular frequency ( $\omega$ ). Use the pan balance to determine the effective mass. Use that information to calculate  $k$ . Compare to the value found Activity 1 using percent difference.

### Activity 4: Finding k Using Spring Energy

Using the points of maximum elastic kinetic energy and maximum elastic potential energy, calculate  $k$ . (Hint: if energy is conserved, the maximum elastic kinetic energy should equal the maximum elastic potential energy.) Compare to the value found Activities 1 and 2 using percent difference.

### Activity 5: Spring Energy

Under the data menu, make new calculated columns which calculate  $PE_{\text{elastic}}$ ,  $KE_{\text{elastic}}$ , and  $ME_{\text{elastic}}$ . For help making calculated columns, please review the document on Graphing with Logger Pro, particularly numbers 6 and 7. Plot these three representations of the energy of the spring onto the same graph, and examine them carefully. Is  $ME_{\text{elastic}}$  constant? If not, why?

### Hints, suggestions, other possibly useful information for this lab

- "Non-zero reference point for position versus time graphs." For some reason, some combinations of motion detector, LabPro, and computer generate a position versus time graph of the mass-spring oscillation that is not centered around zero. In other words, when you zero the motion detector, it does not completely zero. You can notice the effect the most when looking at the graph of  $PE_{\text{elastic}}$ . Every other peak will be higher than the other peaks. This is because  $PE_{\text{elastic}}$  is calculated using  $x^2$  where  $x$  is measured from Zero. If this value is off, then  $PE_{\text{elastic}}$  will be off.
  - To test for this problem, zero the motion detector. Make sure the mass-spring system is as still as possible. Monitor the position versus time graph for a few seconds. Determine the average position for your graph.
  - When this test was done with one experimental set-up, the average position was  $0.0033 \text{ m} = 3.3 \text{ mm}$ . While  $3.3 \text{ mm}$  may not seem like much of an offset for many experiments, it is enough to throw off any calculations that depend on distance.
- Sampling issues: When using digital systems to acquire data, one needs to be aware of how many pieces of data can be measured each second. This is referred to as the "sampling rate." The more samples you can collect each second, the better the data, especially when graphing. However, collecting more samples each second means collecting more samples for the entire experiment, storing them, analyzing them, etc. This is all dependent on the electronics (LabPro, probes & sensors, computer, etc.) involved in the experiment. For this experiment, the sampling rate can affect the data collected, especially when recording the position. Since velocity depends on how the

position changes with time, this will have an effect on both KE and  $PE_{\text{elastic}}$  which, in turn, affects the total energy of the system.

- To test the effects of sampling on your data, go to Data Collection (under Experiment). Increase the sampling rate. [Note: there will be a limit to how much you can increase this value.]
- Repeat the mass-spring oscillation experiment. Does the "jaggedness" of the total energy curve increase, decrease, or stay the same? If the jaggedness decreases, then one source of error for your experiment may be the sampling rate limitations of the equipment.
- Are there other sources for the energy to go into that are not accounted for in the above activities?
- How do the in-lab activities relate to the pre-lab computer simulation activities?

## QuickGuide to Energy and Work

### Introduction

Energy is a property of an object that allows objects to “do” something. Energy is found in different forms, such as light, heat, sound and motion. There are many forms of energy, but they can all be put into two categories: kinetic and potential. Kinetic energy deals with the energy of an object in motion, such as a ball rolling, a fan spinning, or atoms vibrating. Potential energy, however, deals with the “potential” for an object to “do” something. For instance, gravitational potential energy is when an object is some vertical distance above a reference point, like a ball located above the ground. The ball then has the potential to move (do something) IF the ball is allowed to fall. Similarly, a compressed or stretched spring has the potential to oscillate, if it is allowed to move when you let go.

In physics, what can be done with the energy is explained by the concept of “work.” In order for an object to get the energy in the first place (get the ball rolling, stretch/compress a spring, etc.) requires some force to act on the object over some distance. For instance, to stretch a spring, you need to pull the string in the direction that you want the spring to stretch. How much force you apply and how far you stretch the spring gives you information about how much work was done (by you) on the spring. The work you did is now in the form of potential energy. Once you let go of the spring, the spring can now cause work to be done on the object (a net force acting in a particular direction). This work is now the kinetic energy of the object as it flies off the spring.

The key factor to remember is that all energy (kinetic and/or potential) came from some force acting on the object. That energy can then be used to do work in other situations and vice versa.

### ***KINETIC ENERGY***

**Kinetic energy** is motion—of waves, electrons, atoms, molecules, substances, and objects.

**Electrical Energy** is the movement of electrical charges. Everything is made of tiny particles called atoms. Atoms are made of even smaller particles called electrons, protons, and neutrons. Applying a force can make some of the electrons move. Electrical charges moving through a wire is called electricity. Lightning is another example of electrical energy.

**Radiant Energy** is electromagnetic energy that travels in transverse waves. Radiant

### ***POTENTIAL ENERGY***

**Potential energy** is stored energy and the energy of position—gravitational energy. There are several forms of potential energy.

**Chemical Energy** is energy stored in the bonds of atoms and molecules. It is the energy that holds these particles together. Biomass, petroleum, natural gas, and propane are examples of stored chemical energy.

**Stored Mechanical Energy** is energy stored in objects by the application of a force. Compressed springs and stretched rubber bands are examples of stored mechanical energy.

energy includes visible light, x-rays, gamma rays and radio waves. Light is one type of radiant energy. Solar energy is an example of radiant energy.

**Thermal Energy**, or heat, is the internal energy in substances—the vibration and movement of the atoms and molecules within substances. Geothermal energy is an example of thermal energy.

**Motion Energy** is the movement of objects and substances from one place to another. Objects and substances move when a force is applied according to Newton's Laws of Motion. Wind is an example of motion energy.

**Sound** is the movement of energy through substances in longitudinal (compression/rarefaction) waves. Sound is produced when a force causes an object or substance to vibrate—the energy is transferred through the substance in a wave.

**Nuclear Energy** is energy stored in the nucleus of an atom—the energy that holds the nucleus together. The energy can be released when the nuclei are combined or split apart. Nuclear power plants split the nuclei of uranium atoms in a process called **fission**. The sun combines the nuclei of hydrogen atoms in a process called **fusion**. Scientists are working on creating fusion energy on earth, so that someday there might be fusion power plants.

**Gravitational Energy** is the energy of position or place. A rock resting at the top of a hill contains gravitational potential energy. Hydropower, such as water in a reservoir behind a dam, is an example of gravitational potential energy.

## Activities

### Part 1: Ball Toss

Open the file “Ball Toss.cmbl” file in LoggerPro (in folder Sample Movies > Ball Toss).

When you click on the "start" button in the REPLAY window, you will see the position and velocity graphs generated by the motion detector that is on the table top under the ball. On the top menu, click the "next page" icon to see the data table generated by the motion detector.

Using the position data column, create a New Calculated Column that calculates the gravitational potential energy for the ball toss video.

$$PE_{\text{grav}} = mgh$$

To review how to create this new column, please see the document on Graphing with Logger Pro, particularly numbers 6 and 7. Graph PE versus time.

*Question:* What happens to the gravitational potential energy ( $PE_{\text{grav}}$ ) during the ball toss?

Using the velocity data column, create a New Calculated Column that indicates the kinetic energy for the ball toss video.

$$KE = 1/2mv^2$$

Plot KE on the same graph as PE.

*Question:* What happens to the kinetic energy (KE) during the ball toss?

Make a New Calculated Column that calculates the *total mechanical energy* (the sum of potential and kinetic) for the ball toss.

$$ME = KE + PE$$

Plot ME on the same graph as PE and KE. Be sure to show a legend. Print this graph.

*Question:* What happens to the total mechanical energy during the ball toss?

Part 2: Conservation of Energy of a Rolling Cart

Refer to the “QuickGuide to Conservation of Energy of a Rolling Cart” activity document.

Part 3: Conservation of Energy of a Bouncing Ball

Refer to the “QuickGuide to Conservation of Energy of a Bouncing Ball” activity document.

# QuickGuide to Conservation of Energy of a Rolling Cart

## Introduction

The motion of a cart rolling down a ramp can be examined using a motion detector. In previous activities in lab and class, you determined that as a cart rolls down a ramp, it speeds up until it strikes reaches the end of the ramp. In addition to examining the position and velocity of the cart as it rolls, the *total mechanical energy* (*ME*) of the cart can be found. ME is the sum of *the kinetic and gravitational potential energies* of the cart.

The cart has gravitational potential energy (PE) if it is some vertical height above a predetermined reference point (perhaps the table top); the greater the distance, the greater the gravitational potential energy. The cart has kinetic energy (KE) if it has a non-zero velocity; the greater the velocity, the greater the kinetic energy. The mass of the cart also plays a role. Putting all of this together, the various energies can be expressed as follows:  $PE_{\text{grav}} = mgh$ ,  $KE = \frac{1}{2}mv^2$ , and  $ME = KE + PE$ .

If there are no external forces acting on the cart (like friction, air resistance, etc.), then ME is conserved. In other words, the ME at any time during the cart's motion is the same as the ME at any other time. The only thing that changes is where that energy is. For instance, at the point just when the cart is released, the energy is all PE. Halfway down the track, ME is half PE and half KE, and so on. One goal for these activities is to determine if ME is conserved.

## Materials

Lab Pro and computer  
Motion detector  
Inclined track  
Rolling Cart  
Plastic Ruler

## Preliminary Questions and Activities

For each question, consider the free-fall motion of a cart rolling down a track. Assume that there is very little friction or air resistance.

1. Let the table top be the zero point for gravitational potential energy. The instant after the cart leaves your hand, what form of mechanical energy does the cart mostly have?
2. The instant before the cart reaches the end of the track, what form of mechanical energy does it mostly have?
3. **Prediction:** Sketch a graph of velocity versus time for the cart from the time it leaves your hand to the time it reaches the end of the track. Be sure to include a written explanation of why your graph looks the way it does.



4. **Prediction:** Given what you sketched for velocity versus time, sketch a graph of kinetic energy versus time. Be sure to include a written explanation of why your graph looks the way it does.
5. **Prediction:** Sketch a graph of vertical position versus time for the cart from the time it leaves your hand to the time it reaches the end of the track. Be sure to include a written explanation of why your graph looks the way it does.
6. **Prediction:** Given what you sketched for position versus time, sketch a graph of potential energy versus time. Be sure to include a written explanation of why your graph looks the way it does.
7. Identify the point(s) on your position versus time graph where kinetic energy is at a maximum and a minimum.
8. Identify the point(s) on your position versus time graph where gravitational potential energy is at a maximum and a minimum.
9. If there is no friction or air resistance acting on the cart, how is the change in gravitational potential energy related to the change in kinetic energy? Describe in words.

### Activities

Use a motion detector to create a graph of position versus time and velocity versus time for a rolling cart on an incline.

### Analysis

Devise a method to relate the position data to the vertical height of the cart relative to the end of the track. Note that the position of the cart as given by the motion detector of the cart is NOT its vertical height! Create a New Calculated Column that indicates the gravitational potential energy for the cart. To create this new column, please review the document on Graphing with Logger Pro, particularly numbers 6 and 7. Graph PE versus time.

Using the velocity data column, create a New Calculated Column that indicates the kinetic energy for the cart. Plot KE on the same graph as PE.

Make a New Calculated Column that indicates the *total mechanical energy* (PE + KE) for the cart. Plot ME on the same graph as PE and KE. Be sure to show a legend indicating which line is which. To create this graph, please review the document on Graphing with Logger Pro.

### Questions:

1. Were your predictions correct? What is the relationship between potential, kinetic, and total mechanical energy?

2. Examine your graph. Are you able to see the effects of friction and air resistance in this experiment? Explain.
3. Refer to the Projectile Motion laboratory in your notebook. Calculate the gravitational potential energy of the ball just before it started rolling down the ramp. What is the change in potential energy from the top of the ramp to the bottom?
4. Now calculate the kinetic energy of the ball as it is coming off the end of the ramp.
5. Was energy conserved? In other words, was all of the gravitational potential energy of the ball converted to kinetic energy? If not, how much energy was lost? What could be the cause of this loss of energy?

# QuickGuide to Conservation of Energy of a Dropped Ball

## Introduction

The motion of a dropped ball can be examined using a motion detector. As the ball falls to the ground, it speeds up until it strikes the ground. At that point, it reverses direction and bounces off the ground and back into the air. In addition to examining the position and velocity of the ball as it falls and bounces back, the *total mechanical energy (ME)* of the ball can be found. ME is the sum of the kinetic *and* gravitational potential energies of the ball.

The ball has gravitational potential energy (PE) if it is some vertical height above a predetermined reference point; the greater the distance, the greater the gravitational potential energy. The ball has kinetic energy (KE) if it has a non-zero velocity; the greater the velocity, the greater the kinetic energy. The mass of the ball also plays a role. For example, these factors can easily be observed by dropping different mass balls from the same height onto sand. All the balls will have the same velocity before hitting the ground. But, the more mass a ball has, the more work it can do on the sand and the greater the divot (hole) the ball can make.

Putting all of this together, the various energies can be expressed as follows:  $PE_{\text{grav}} = mgh$  and  $KE = \frac{1}{2}mv^2$ . There are other types of energy to consider, which we will not directly measure. These include the elastic gravitational potential energy  $PE_{\text{elastic}}$  of the ball. When the ball strikes the ground, it compresses like a spring, and the kinetic energy is converted to elastic potential energy.

If there are no external forces acting on the ball (like friction, air resistance, etc.), then ME is conserved.

## Materials

Lab Pro and computer  
Motion detector  
Rubber ball  
Table clamp, rod, and three-finger clamp

## Preliminary Questions:

1. **Prediction:** Sketch a graph of vertical position versus time for a bouncing ball. Be sure to include a written explanation of why your graph looks the way it does.
2. **Prediction:** Sketch a graph of velocity versus time for a bouncing ball. Be sure to include a written explanation of why your graph looks the way it does.
3. Identify the point(s) on your position versus time graph where kinetic energy is at a maximum and a minimum.

4. Identify the point(s) on your velocity versus time graph where gravitational potential energy is at a maximum and a minimum.
5. If there is no air resistance acting on the ball, how is the change in gravitational potential energy related to the change in kinetic energy? Describe in words.

**Activities:**

Measure and record the mass of the ball you plan to use in this experiment. Position a motion detector above the floor or table so that it will be able to map the motion of a bouncing ball.

Click the following link to open the Logger Pro file titled “BallBouncePV.cmbl.” Internet Explorer will directly load the program. If you are using FireFox, you will have to right-click on the above link and save it to the desktop before opening. When the file has loaded, zero the motion detector (press Ctrl-0) while it is aimed at the top of the ball which is resting on the table. Use the motion detector to create a graph of position versus time and velocity versus time for a bouncing ball.

**Analysis:**

Using the position data column, create a New Calculated Column that indicates the gravitational potential energy of the ball. To create this new column, please refer to #6 the document on Graphing with Logger Pro. Go to Insert > New Graph and create a graph of PE versus time. Scale the graph so that three full bounces of the ball are shown.

Using the velocity data column, create a New Calculated Column that indicates the kinetic energy of the ball. Plot KE on the same graph as PE. To show multiple data sets on the same graph, refer to #7 in the document on Graphing with Logger Pro. Be sure to show a legend indicating which line is which.

Make a New Calculated Column that indicates the *total mechanical energy* (PE + KE) for the ball. Plot ME on the same graph as PE and KE. Print this graph.

**Postlab Questions:**

1. Describe, in your own words, the transitions of the total mechanical energy of the ball in terms of kinetic energy, gravitational potential energy, and elastic potential energy.
2. As the ball bounces upwards, it is said to be in *free fall*, even though it is moving upward. Why a ball is said to be in free fall even though it is on its way up?
3. What happened to the total mechanical energy of the ball between bounces? Does the total energy remain constant? Should it? Why?
4. What would change in this experiment if you used a very light ball, like a beach ball, that was affected more by air resistance?
5. Try to devise an experiment that would enable you to determine the transition of the mechanical energy of the ball to elastic potential energy when the ball is in contact with the ground.

## Quick Guide to Momentum and 1D-Collisions

### Introduction

Momentum is a property of an object in motion (ie, “inertia in motion”). To determine how much momentum an object possesses, you have to know the object’s inertia (resistance to a change in motion) and its actual motion. In lab, we can measure an object’s inertia by measuring its mass, and an object’s motion by measuring its velocity. Mathematically, this means that momentum ( $p$ ) is the product of mass ( $m$ ) and velocity ( $v$ ).

$$p = mv$$

Knowing an object’s momentum is useful when observing the object over time. If the momentum of the object remains the same, this relates to Newton’s First Law of motion. However, if the momentum of the object changes, then the Second Law comes into play. In fact, another way to mathematically restate Newton’s Second Law is:

$$F_{\text{net}} = ma = \Delta p / \Delta t$$

That is, in order for the momentum of an object to be changed, a net force has to be applied to it over a period of time. This change in momentum,  $\Delta p$ , is also known as **impulse**. For those who play "contact" sports where one object contacts another (golf, soccer, tennis, etc.), then the biggest impulse occurs when you hit the ball/object with the most force for the longest time. (The ball/object gets to travel the furthest after the contact.) Since the "most force" is based on your muscle strength, then one thing you work to control and improve is  $\Delta t$ , or the time of contact. The longer the time of contact (or, *follow through*), the more effect you can have on the ball/object.

In physics, momentum is used to examine a variety of activities: sports, rockets, and collisions. Knowing the momentum can help predict motion, time, and forces involved. However, one of the most useful aspects of momentum is that it is **conserved**. Like energy, momentum of a **system** is conserved. Unlike energy, conservation of momentum is mathematically more challenging because energy is a scalar, while momentum is a vector. This means that the motion in ALL directions (x, y, and z) have to be examined and vector addition has to be used.

One example of momentum conservation is during one-dimensional collisions. These are collisions where all the motion is in one-direction, say, the x-direction. This can be seen in real life when two railroad cars collide in a rear-end collision. Both cars remain on the track (in a line), but their velocities can be “+” or “-” based on the collision. For this situation, conservation of momentum for the system can be mathematically represented as:

$$p_i = p_f$$

In other words, the total momentum of a system before a collision has to equal the total momentum of a system after a collision.

### **Materials**

LabPro with computer

Motion detector

Logger Pro

Two, low-friction carts with Velcro bumpers

Track for carts

Force probe

### **Activities**

#### Part 1: 1-D collision

Objective: Confirm the conservation of momentum throughout a collision of two carts. Is energy also conserved?

This activity uses two carts. Make sure each cart has a different mass by adding mass to one of the carts. For this activity, it is difficult to monitor the motion of two carts at once, so keep the one of the carts at rest before the collision. Align the Velcro pads so that the two carts stick together after the collision. This way, the motion of initially rolling cart can be observed before, during, and after the collision. Practice rolling one cart at a moderate velocity into the other. Make sure the moving cart has approximately constant velocity as it approaches the stationary cart. Make sure the track is level. (What effect would a non-level track have on the motion of the carts?)

Under the Experiment menu, select Data Collection. Set the sample rate to 250 samples per second.

When you have created a good velocity versus time graph of the collision, verify that momentum is conserved in the collision. Compare the total momentum just before the collision to the total momentum just after collision using percent difference. Is the percent difference within "experimental error?" Explain.

Since conservation of energy still applies, is energy conserved in the collision? Calculate the total mechanical energy of the cart before and after the collision. Is there any change in gravitational potential energy? Is there any change in kinetic energy? What percentage of energy is conserved in the collision? Explain.

#### Part 2: Impulse

Objective: Keeping Newton's laws in mind, examine the impulse during a collision between a moving cart and a stationary force probe. Set the range on the force sensor to +/- 50 N, and again set the sample rate to 250 samples per second. Examine the momentum just before and just after the collision to determine the impulse using the motion detector.

Use the force sensor to measure the average force during the collision. There are several ways to determine the average force. You can highlight the data and examine the statistics, or integrate using the icon below:



One way to make sure the probe is stationary is to brace it against an attachment that goes onto the end of the track. Be sure to calibrate and zero your force sensor before you begin!

Impulse is also known as the change in momentum. Using the velocity versus time graph and the mass of the cart, determine  $\Delta p$ .

Compare the impulse found using the force probe with that found using the motion detector.

### Part 3: Ballistic Pendulum

Fire the ballistic pendulum horizontally from the tabletop to the floor in order to determine the initial velocity of the projectile. For greater accuracy, do this without using a stopwatch.

Next you will fire the ball into the cup. The two will stick together and then rise to some maximum height together.

First, you must make the assumption that the mechanical energy of the ball/cup is conserved after the collision. Therefore, the kinetic energy of the ball/cup just after the collision is equal to the potential energy due to the change in height of the center of mass of the ball/cup when it swings up to its maximum height.

Next, you must make the assumption that momentum is conserved through the collision. Therefore, the momentum of the ball/cup immediately after the collision is equal to the momentum of the ball just before the collision (the cup is initially stationary). Use this idea to find the initial velocity of the projectile, and compare it to the initial velocity found earlier (use percent difference).

## Quick Guide to 2D-Collisions

### Introduction

In the Quick Guide to Momentum and 1D-collisions, the concept of conserving momentum during a collision was discussed and explored. In the real world, most collisions occur in two (or three) dimensions. Some examples are: car crashes, sports (e.g., tackling in football), and sub-atomic particles. In all of these situations, momentum for the system is conserved. However, the process of calculating the conserved momentum becomes more complicated. Since velocity (and therefore momentum) is a vector, it must be treated as such in two dimensions. The best way to do this is to separate the momentum vector into its X and Y components. If the total momentum is conserved, then the vector "sum" of the X and Y momenta is also conserved.

For many collisions, information is available (or can be found) about the velocity of each object both before and after the collision. (**NOTE:** It is important to obtain the velocities as close to the collision site as possible. This reduces the effects of friction, spin, or other factors that might affect the collision.) The direction of each object can be measured *as long as* a common reference frame (X-Y coordinate system) is used. The direction, i.e., angle, can be used with each velocity to find the X and Y velocities of EACH ball both *before* and *after* the collision (remember your trigonometry here). This way, the X-momentum of the system BEFORE the collision can be compared with the X-momentum of the system AFTER the collision. Similarly, the Y-momenta of the system can be compared before and after the collision. Together, the X and Y components of the system's momentum can be put together to find the *total momentum* (both magnitude and direction) both before and after the collision.

Although this process can be tedious, conserving momentum in each direction provides useful information. For instance, during a practice run of a 2-D collision, it was observed that momentum was conserved in the x-direction (within 10% for the experiment involved), but the y-direction values were way off (much greater than 10%). After careful examination, it turned out the floor was tilted, in the direction that was designated as the "y-direction." The difference in the before and after y-momentum values was due to an *external force*, here, the force of gravity, causing the balls to speed up during the experiment. In high energy physics, knowing that momentum is conserved in collisions help scientists search for new particles and interactions, such as the Large Hadron Collider in Europe.

The reason momentum can be used to hunt for external forces links back to Newton's Second Law:

$$F_{\text{net}} = ma = m\Delta v/\Delta t$$

Since  $p = \text{momentum} = mv$ , Newton's Second Law can be rewritten as

$$F_{\text{net}} = \Delta p/\Delta t$$



so any change in the momentum is caused by a net force.

Another use for momentum is verifying Newton's Third Law. The key for understanding the 3rd law is to remember that it deals with the interaction between *two objects*. When two objects interact with each other, then the force that object #1 exerts on #2 is *equal and opposite in direction* to the force that object #2 exerts on #1. In other words, #1 can't be affected without #2 being affected as well (an equal amount and in the opposite direction). This effect can be observed during collisions by examining the force that each object "feels" during the collision. If force probes are used, the force that each object experiences can be observed directly. If not, the force that each object "feels" (i.e., the force needed to change each object's motion) can be calculated using the "new and improved" form for Newton's 2nd Law. These forces can then be compared to verify the 3rd law.

In addition, these forces can be used to discuss the amount of "damage" that might occur during "every-day" collisions. Although the mass of a large delivery truck is much larger than a Volkswagen Jetta, Newton's 3rd Law predicts that the collision force each vehicle experiences would be the same. If so, why does the Jetta end up totaled while the delivery truck simply becomes dented?

## MATERIALS

- Digital video camera
- LoggerPro
- Various balls and pucks
- Mass balance

## ACTIVITIES

### Part 1: Conservation of Momentum: Puck Collision

Open Logger Pro and insert this movie of two pucks colliding. You may have to save it to your desktop first.

Your objective is to find the total momentum of both pucks before the collision and compare it to the total momentum of both balls after the collision. Remember the momentum is a vector quantity, and so you must begin by breaking the motion of the balls down into X and Y components that can be added like scalars. Logger Pro's video analysis software does this automatically for you.

Use the first frame of the movie to set the scale and to find the masses of the pucks. After you set the scale, use the video analysis tools in Logger Pro to mark the paths of the pucks before the collision. You will notice that Logger Pro automatically generates a plot of the X and Y positions of the ball as it changes with time. You will want to expand the size of the movie for greater clicking accuracy.

From the position versus time graphs, determine the X and Y velocities of the pucks before and after the collision. Then, given the mass, determine the X and Y momenta. Combine the

X and Y values to find the momentum vector (magnitude and angle) before and after the collision.

Compare both the magnitude and the angle to the total momentum before the collision using percent difference. Within experimental error (probably about 10% for this activity), is momentum conserved? If not, what external forces or factors could affect your experimental results?

### Part 2: Verifying Newton's Third Law

During a collision, object #1 changes its motion because object #2 hits it. Similarly, object #2 changes its motion because object #1 hits it. Since the motion (velocity) of each ball changes, the force on each object can be calculated using Newton's Second Law:  $F_{\text{net}} = ma = m\Delta v/\Delta t = \Delta p/\Delta t$ , where  $\Delta p = p_f - p_i$ . The frame rate is listed on the first frame of the movie. Use the X and Y momenta found in Part 1 to verify Newton's Third Law. Remember that velocity is a vector quantity, so your forces will have magnitude and direction.

### Part 3: Conservation of Momentum: Air Table

You will be given a photocopy of a collision between a moving puck and a stationary puck. As the pucks moved across carbon paper, holes were burned from the center of the pucks through the paper at a rate of 20 holes per second. Your instructor will demonstrate this collision. Given that the mass of each puck was .567 kg, compare the total momentum before the collision to the total momentum after the collision. Again, compare both magnitude and angle using percent difference.

# QuickGuide to Torques and Rotation

## Introduction

From Newton's 2nd Law of Motion, in order for the motion (velocity) of an object to change, a net force must be applied. However, there are other types of motion than *translational* (moving from point A to point B) motion. In particular, there is *rotational* (or angular) motion where the object's orientation changes. This can best be seen when an object spins. One moment the top is facing upward, the next moment it is facing sideways, then downward, etc.

Just as Newton's 1st Law deals with an object maintaining its motion (velocity) *UNLESS* an external force is applied, then an object that has rotational wants to maintain its rotational motion unless a *torque* is applied. The question now is: What is torque? The simple answer is: It's what you have to do to cause an object to rotate (or to stop rotating). Think in terms of trying to rotate a bicycle wheel by hand. The best way is to push (or pull) on the tire. If you push/pull along the spokes, the wheel rotates, but not as quickly as when you push/pull along the tire, further from the center of the wheel, or the axis of rotation. So, the two main ingredients of torque are: 1) the force that is applied and 2) how far from the axis of rotation (the point about which the object rotates).

There is a 3rd ingredient, the direction you apply the force. For instance, to make the wheel rotate, you push/pull on the tire, but tangent to the wheel (or perpendicular to one of the spokes). If your push/pull was in the same direction of the spoke, the tire would not rotate (but you would be able to translate it from point A to point B). As a result, the way torque can be found (calculated) is:

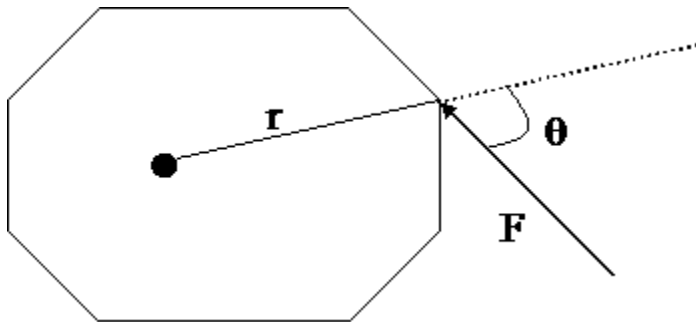

$$\tau = F r \sin\theta$$

where  $F$  is the applied force,  $r$  is the distance from the axis of rotation to where the force is applied, and  $\theta$  is the angle between the directions of the applied force and the distance.

With forces, an object can be in equilibrium if the object has constant velocity (including a velocity of zero). In this case, the net force on the object is zero. However, there is more to equilibrium. In fact, to be in equilibrium, the object must also have constant angular velocity (including an angular velocity of zero). This means that the net torque on the object is zero (the sum of all the torques trying to rotate the object clockwise minus the sum of all the torques trying to rotate the object counterclockwise).

## MATERIALS

- Meter stick
- Clamp with knife edge
- Support for meter stick
- Clamps for hanging masses
- Masses
- Force probe

## ACTIVITIES

### Part 1: Meter stick equilibrium – “Location, Location, Location”

Find the balance point of the meter stick and place a fulcrum there.

Add a 200 gram mass at the 65.0 cm mark and a 100 gram mass at the 90.0 cm mark. Predict mathematically where a second 200 gram mass should be placed for there to be equilibrium. (Don't forget to add in the masses of the hangers and the clips! You'll have to mass these on the pan balance.)

Once you have made your prediction, experimentally determine the equilibrium position. (Remember, you are interested in the distance from the applied force to the axis of rotation, not the actual meterstick reading.) Compare with your predicted value using percent difference.

### Part 2: Meter stick equilibrium – “Weight, Weight, Don't Tell Me”

With the balance point of the meter stick kept the same, place 500 grams at 65.0 cm, 100 grams at 80.0 cm, and 200 grams at 20.0 cm. Mathematically predict the value of the mass that must be located at 35.0 cm for there to be equilibrium. (Don't forget to include the mass holders.)

Once you have made your prediction, use the Vernier force sensor to experimentally determine the unknown mass at 35.0 cm and compare with the predicted value using percent difference.

Same problem, different technology: Instead of the Vernier force sensor, use the slotted masses to determine the unknown mass at 35.0 cm. Compare your results with those found previously using percent difference.

### Part 3: Meter stick mass – “A Well-Balanced Life”

Devise an experiment to determine the mass of the meter stick using the ideas explored in Parts 1 and 2. Measure the mass of the meter stick directly and compare the two values.

### Question(s)

Explain why the gravitational force (weight) of the meter stick does not affect any of the torques for Parts 1 and 2.

# QuickGuide to Centripetal Force

## Introduction

When an object goes around a curve or travels in a circle, even if the speed remains constant, there is an acceleration. This can best be understood by looking at Newton's Laws of Motion. The 1st Law deals with keeping the velocity constant, which includes keeping both magnitude and direction the same. When the direction changes, the velocity vector changes, and some force has to cause that change. Otherwise, the object will continue in a straight-line path, much like a car will continue in a straight line while trying to drive on an ice-covered mountain road.

Because there is a net force causing the direction to change, there has to be an associated acceleration (Newton's 2nd Law). This is counterintuitive, because most people don't think that there is an acceleration when an object is moving at a constant speed. However, because velocity is a vector, it is changing because the direction is changing (even though the magnitude may not be). And as we know, acceleration is the rate of change of velocity. If the object is moving at a constant speed  $v$  around a fixed radius  $R$ , then the velocity is changing at a constant rate, which translates to a constant acceleration. This change in velocity due to a direction change **only** is shown in the following equation:

$$a_c = v^2/R$$

This acceleration is referred to as *centripetal* acceleration to distinguish the acceleration of a "direction change" from the acceleration due a "magnitude change" (change in speed). Centripetal means "center seeking" because the acceleration vector points toward the center, in the same direction as the net force required to make an object move along a curve instead of following the 1st Law.

## MATERIALS

- Iron Ball
- String
- Meter stick
- Pulley
- Pendulum support
- Hanger and slotted masses
- Table clamp
- Vernier caliper
- Force probe with LabPro (optional)
- Computer with LoggerPro

## ACTIVITIES

These activities represent three different methods for determining the net (centripetal) force.

### Activity 1: Calculating the net force using a force diagram

When the ball is moving along a circular path, there must be a net force causing the direction change in the ball's velocity. This is an example of an unbalanced force or Newton's 2nd Law application.

Set the ball moving so it follows a circular path. [**Note:** This experimental set-up is referred to as the "conical" pendulum because the motion of the string sweeps out a cone as the ball moves in a circle and the motion repeats itself, a characteristic of a pendulum.] Make sure that you know the radius of the circular path!

Starting with a sketch and a force diagram, determine the forces acting on the ball. Then use a little geometry and trigonometry to determine the net force acting on the ball. [**Note:** The net force for an object moving with a constant speed in a circular path is referred to as the *centripetal force*.]

### Activity 2: Finding the net force using the velocity of the ball

Determine the speed of the ball as it travels around the same radius as in activity 1. Is the speed constant? Is the velocity constant? Using the above equation for determining the acceleration due to a direction change, calculate the force causing the centripetal acceleration. How does this determination of the centripetal force compare to the net force found in activity 1? Use percent difference.

### Activity 3: Finding the net force by setting up a balanced system

In activities 1 and 2, there was a net force acting on the ball. However, by applying a force that is the equilibrant (the same magnitude but in the opposite direction) of the net force, you can create a balanced situation that has no net force and no acceleration. Use a force probe to apply this equilibrant force. Make sure that the ball is positioned at the same radius as in activities 1 and 2! Explain how this method gives you information about the magnitude and direction of the centripetal force. Determine the centripetal force and compare to the values found in activities 1 and 2. Use percent difference.

### Activity 4 : Repeat!

If time allows, repeat the previous activities using a different radius.

# QuickGuide to the Speed of Sound

## Introduction

Sound waves passing through the air cause air molecules to move back and forth parallel to the direction that the wave is traveling. This back and forth motion of the air molecules results in alternating regions of high pressure and low pressure. A region of high pressure is called a "compression," and a region of low pressure is called a "rarefaction." The time it takes for a region to be compressed, and then rarefied, is called the *period* ( $T$ ). It is measured in seconds. The number of times that a region is compressed in one second is called the *frequency* ( $f$ ). Frequency is measured in Hertz (Hz), which is the inverse of a second. The *wavelength* ( $\lambda$ ) is the physical distance from one point of compression to the next, and it is measured in meters. Using a microphone, we can determine the frequency of a sound by graphing air pressure versus time and observing the pattern set up by the constantly changing volume. This pattern is called a waveform.

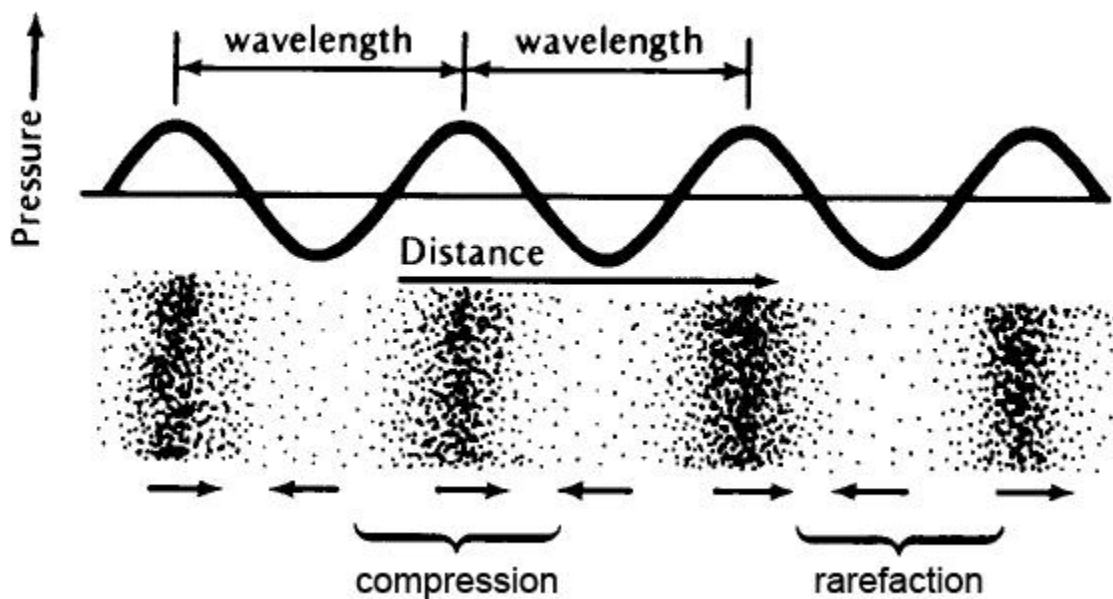

Figure 1.

A disturbance, such as a finger-snap, will cause the movement of air molecules as described above. These air molecules disturb adjacent molecules, creating a domino effect that causes the wave to propagate outward. The velocity of the wave, known as the **speed of sound** ( $V_s$ ), describes the distance that a sound wave travels outward in a certain amount of time. It has units of m/s. This speed is related to density and stiffness of the material that it is moving through. The speed of sound is also temperature dependent:  $V_s = [331 + .6T] \text{m/s}$  indicates the

speed of sound in air where  $T$  is the temperature in degrees Celsius.

Consider a continuously produced tone, like the sound generated by a tuning fork. If there is a hard surface to reflect the sound, the echo will double back and interfere with the tone that is coming from the fork. The sound heard is then the sum of the tone and its echo. If the tone doubles back on itself in a way that is symmetrical, with the compressions due to the echoes in the exact same positions as the compressions due to the original tone, then the pressure will be doubled. This will result in a noticeable change in volume. In order for the sound to interfere in this way, the reflective surface has to occur at the exact center of a compression or a rarefaction. This constructive interference is called a standing wave.

## MATERIALS

- Variable-length resonance tube
- Computer and LabPro
- Vernier Microphone
- Various tuning forks
- Thermometer

CAUTION: DO NOT STRIKE THE FORKS TOGETHER OR ON A HARD SURFACE!!!

## ACTIVITIES

### Activity 1: Calculating the speed of sound based on room temperature

Record the temperature inside the variable-length resonance tube. Calculate the speed of sound in the lab based on the current temperature.

### Activity 2: Using echoes to determine the speed of sound

You learned last semester that  $v = d/t$ . If the speed of sound is constant at a fixed temperature, then the longer the distance traveled, the longer the time. Examine the equation carefully. Can you model this graphically with a linear equation in the form  $y = mx$ ? Keeping velocity constant what do you need to vary in order to make a graph?

Design an experiment using a microphone to time the echo of a finger snap in a variable-length tube. Acquire enough data to produce a linear graph. Distance will be measured using the meter stick printed on the tube, and time will be measured using the microphone. Below is information on how to acquire the time data:

*Plug the microphone into the LabPro. Power up the LabPro and connect it to the PC. Open Logger Pro. In the **Experiments\Physics with Vernier** folder, open a file called "33 Speed of Sound.cmbl." If the microphone is not automatically detected when you open the experiment file, click the 'Lab Pro' button, or the small image of the Lab Pro near the upper left. A picture of the Lab Pro will appear, with a list of the available ports. From the lists of sensors, find the microphone and drag it to the port where the sensor is connected. With the microphone placed in the mouth of an open tube, snap your fingers. On the computer, you should see evidence of the initial snap, and then an echo as the sound reflects off the end of the tube. If Logger Pro begins to collect data before you snap your fingers, then the trigger threshold may be too low. Under the Experiment menu, go to Data Collection, then click on*



*the Trigger tab. Increase the "Increasing across" value until the software waits for your finger snap to begin collecting data.*

After you have collected your data, create your graph. Is it linear? If so, what does the constant slope tell you about the speed of sound? Determine the speed of sound in the tube and compare to the value calculated in Activity 1 using percent difference. Print the graph.

Activity 3: Using frequency and wavelength to determine the speed of sound.

Since the period of a wave is the time it takes to travel the distance of one wavelength, the period and wavelength may be used in the  $v = d/t$  equation to determine the wave velocity. In the next experiment you will create another distance time graph, but this time your distances will be wavelengths and your times will be periods.

The wavelength can be found by measuring the distance between the centers of compression and rarefaction. As you can see in Figure 1, the distance from the center of a compression to the center of a rarefaction is exactly one half of the wavelength. Instead of snapping your finger into a microphone, you will hold a tuning fork at the entrance of the tube (no microphone needed – you will use your ears). As you vary the tube length, listen carefully for a sudden increase in volume. High volume indicates that a standing wave has been created and the vibrations are interacting constructively. That only happens when the end of the tube is located at the exact center of a compression or the exact center of a rarefaction. Use this idea to determine the wavelength of the tones produced by five different tuning forks.

Stamped on each fork is its frequency. Using this given information, calculate the period of the tone produced by each fork.

Just as in Activity 2, create a (hopefully) linear graph that will allow you to determine the speed of sound. Compare this value to the value found in Activities 1 and 2 using percent difference. Print the graph.

Activity 4: Verifying the frequency of a tuning fork.

Each tuning forked is stamped with a particular frequency. In the following activity, you will verify the frequency of a tuning fork two different ways.

*Plug the microphone into the LabPro as in Activity 2. Open the file named "32 Sound Waves and Beats.cml." Hold the tuning fork near the microphone to produce a continuous tone, then click "collect." Observe the recorded waveform (you may have to auto scale).*

One way to verify the frequency of a tuning fork is to first find the period of the wave. What is the period of oscillation (how much time passes between the top of one waveform to the top of the next)? You may have to zoom in on the waveform. Now determine the frequency (the number of waves that will occur in one second). How does this frequency compare to the value stamped on the tuning fork? Use percent difference.

Another way to verify the frequency of a tuning fork is to fit the produced tone with a sine curve and study the parameters. The formula for a sine wave is  $\text{Amplitude} \cdot \sin(2\pi \cdot \text{frequency} + \text{phase})$ . Examine the parameters of the sine function, and then determine the frequency of

the tone. How does this frequency compare to the value stamped on the tuning fork? Use percent difference. Print the graph.

## POSTLAB QUESTIONS

1. For a wave that is travelling at a constant velocity, what is the relationship between frequency and wavelength? Explain in words.
1. Using the speed of sound from Activity 1 and the frequency you just determined for the fork in Activity 4, determine the wavelength of the tone produced by that fork. Compare this to the wavelength found for this fork in Activity 3 using percent difference.
2. Describe, in your own words, exactly what went on in Activity 3.
4. Carefully examine the temperature-dependent speed of sound equation used in activity one. Can this equation be modeled with a linear equation? If so, what are the independent and dependent variables? What is the significance of the y-intercept? What is the slope, and what are the units of the slope? Sketch a graphical representation of the temperature dependence of the speed of sound.

## QuickGuide to the Microphone

The microphone has a frequency response covering essentially the range of the human ear. The best sound source to use with the microphone is a tuning forks, but you may want to investigate a human voice or a whistle, or other musical instruments. Make sure the sound volume is in the correct range to produce good wave patterns. If the sound is too loud, the wave pattern will be "clipped off" at the top or bottom. If this happens, move the microphone further from the sound source, or turn down the volume of the sound.

### Activity 1: Determining the frequency of a sine wave

Plug the microphone into the LabPro. Power up the LabPro and connect it to the PC. Open Logger Pro. In the *Experiments\Physics with Vernier* folder, open a file called "32 Sound Waves and Beats.cmb1." If the microphone is not automatically detected when you open the experiment file, click the 'Lab Pro' button, or the small image of the Lab Pro near the upper left. A picture of the Lab Pro will appear, with a list of the available ports. From the lists of sensors, find the microphone and drag it to the port where the sensor is connected. Use a musical instrument or a tuning fork near the microphone to produce a continuous tone, then click "collect." Observe the recorded waveform (you may have to autoscale). What is the amplitude? What is the period of oscillation (how much time passes between the top of one waveform to the top of the next)? What is the frequency (how many waves will occur in one second)?

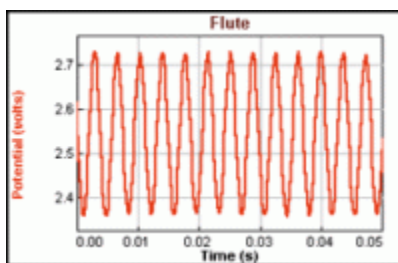

Challenge: Fit the produced tone with a sine curve and study the parameters. The formula for a sine wave is  $\text{Amplitude} * \sin(2*\pi*\text{frequency} + \text{phase})$ . From your parameters, calculate the frequency of the tone.

### Activity 2: Determining the speed of sound

Plug the microphone into the LabPro. Power up the LabPro and connect it to the PC. Open Logger Pro. In the **Experiments\\_Physics with Vernier** folder, open a file called "33 Speed of Sound.cmbl." If the microphone is not automatically detected when you open the experiment file, click the 'Lab Pro' button, or the small image of the Lab Pro near the upper left. A picture of the Lab Pro will appear, with a list of the available ports. From the lists of sensors, find the microphone and drag it to the port where the sensor is connected. With the microphone placed in the mouth of an open tube, snap your fingers. On the computer, you should see evidence of the initial snap, and then an echo as the sound reflects off the end of the tube. If Logger Pro begins to collect data before you snap your fingers, then the trigger threshold may be too low. Under the Experiment menu, go to Data Collection, then click on the Trigger tab. Increase the "Increasing across" value until the software waits for your finger snap to begin collecting data.

## QuickGuide to Horsepower

Source: How Stuff Works (<http://www.howstuffworks.com>)

Chances are you've heard about horsepower. Just about every car ad on TV mentions it, people talking about their cars bandy the word about and even most lawn mowers have a big sticker on them to tell you the horsepower rating. But what is horsepower, and what does the horsepower rating mean? In this lab, you'll learn exactly what horsepower is and how you can apply it to your everyday life.

Before moving on to power, we should probably discuss work. Work, in physics, the movement of a body by a force acting against a resistance. Work is performed when a person lifts a weight, since the person applies a force to move the weight upward. However, no work is done by a person who simply holds the weight above the ground, even to the point of exhaustion. If the weight is allowed to drop, gravity does work by giving the object a downward velocity.

Work is measured by multiplying the force by the distance through which it moves. Force is the push or pull that produces a change in motion. Force is measured in pounds (empirical) or newtons (SI). When one pound of force acts through a distance of one foot, one foot-pound of work is done (empirical). Using SI units; when one newton of force acts through a distance of one meter, one newton-meter of work is done. Another name for the newton-meter is the Joule (J).

Work is related to energy. Energy is the ability to do work, and has the same units as work. Therefore, energy has units of foot-pounds or Joules. Another unit of energy is the food calorie, which is used to describe how much work can be done with a unit of food.

Power is the rate at which work is done. Some common units for work are foot-pounds per minute, food calories per hour, and Joules per second. One of the most common units of power is the horsepower. The term horsepower was invented by the engineer James Watt. Watt lived from 1736 to 1819 and is most famous for his work on improving the performance of steam engines.

$$1 \text{ horsepower} = 33,000 \text{ foot-pounds per minute} = 641 \text{ food calories per hour} = 746 \text{ Joules per second}$$

A Joule per second is also called a watt (W), to remind us of James Watt. The story goes that Watt was working with ponies lifting coal at a coal mine, and he wanted a way to talk about the power available from one of these animals. This way, he could talk quantitatively about how many horses a steam engine could replace. He found that, on average, a mine pony could do 22,000 foot-pounds of work in a minute. Since pit ponies were very small, he increased that number by 50 percent and pegged the measurement of horsepower at 33,000 foot-pounds of work in one minute. It is that arbitrary unit of measure that has made its way

down through the centuries and now appears on your car, your lawn mower, your chain saw and even in some cases your vacuum cleaner.

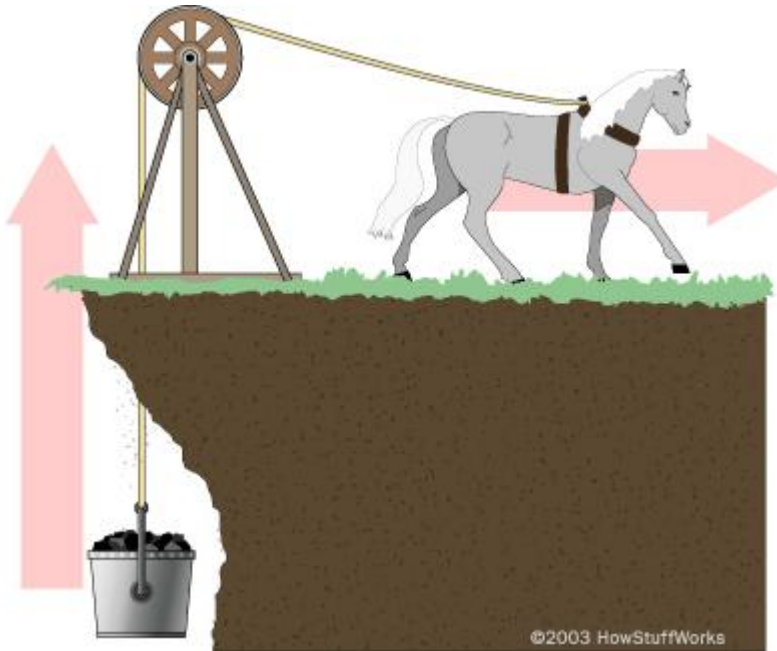

What horsepower means is this: In Watt's judgment, one horse can do 33,000 foot-pounds of work every minute. So, imagine a horse raising coal out of a coal mine as shown above. A horse exerting 1 horsepower can raise 330 pounds of coal 100 feet in a minute.

### **Activity 1: Determining your energy and horsepower**

**CAUTION:** Students who have medical conditions that exclude them from participation in sports or physical education classes should not participate in the first part of this experiment.

Design an experiment that will allow you to determine the power output of a person hurrying up a flight of stairs. Along the way, you will determine how much energy was expended. Be sure to explain your experiment thoroughly, and make clear and careful data measurements and multiple trials for the best accuracy.

Report your energy expended in terms of foot-pounds and joules.

Report your power output in terms of foot-pounds per minute, food calories per hour, Joules per second, and horsepower..

### **Activity 2: Comparing class data**

In this experiment you will compare your energy and power output with that of your classmates (and, perhaps, of your instructor).

Use Excel to compute the average energy and power of the class. Also determine the standard deviation. What is your class rank when it comes to energy and power? Are you within one standard deviation of the mean?

Is there a relationship between student weight and energy expended? What about student weight and power output? Come up with a way to graphically display these relationships.

**Post-Lab Questions:**

- 1) How many stairs could you climb on the energy provided by the 220 food calories found in a glazed Duncan donut?
- 2) You decide to rescue and replace the poor pit pony. Walking at a rate of 100 feet per minute, how many pounds of rock (using pulleys) could you lift out of the mine shaft?

# QuickGuide to Properties of Materials

## INTRODUCTION

In the QuickGuide to Springs, it was observed that the amount a spring stretched was directly proportional to the force that was applied to stretch it. This is known as Hooke's Law. However, there is more to the behavior of materials than Hooke's Law. This is true whether you are using steel for buildings or examining the behavior of biological materials like muscle, tendons, ligaments, and bone.

One property that can easily be explored is the amount of deformation an object experiences when a force is applied to it. This is how the Hooke's Law activity was done. The amount an object (the spring) stretches or contracts ( $\Delta L$ , the deformation) is measured as the force applied to an object is changed. However, in lab, a limited range of forces was used on the spring. If the spring was examined for a full range of forces, from zero to some maximum value, the resulting graph would look similar to that shown in Figure 1.

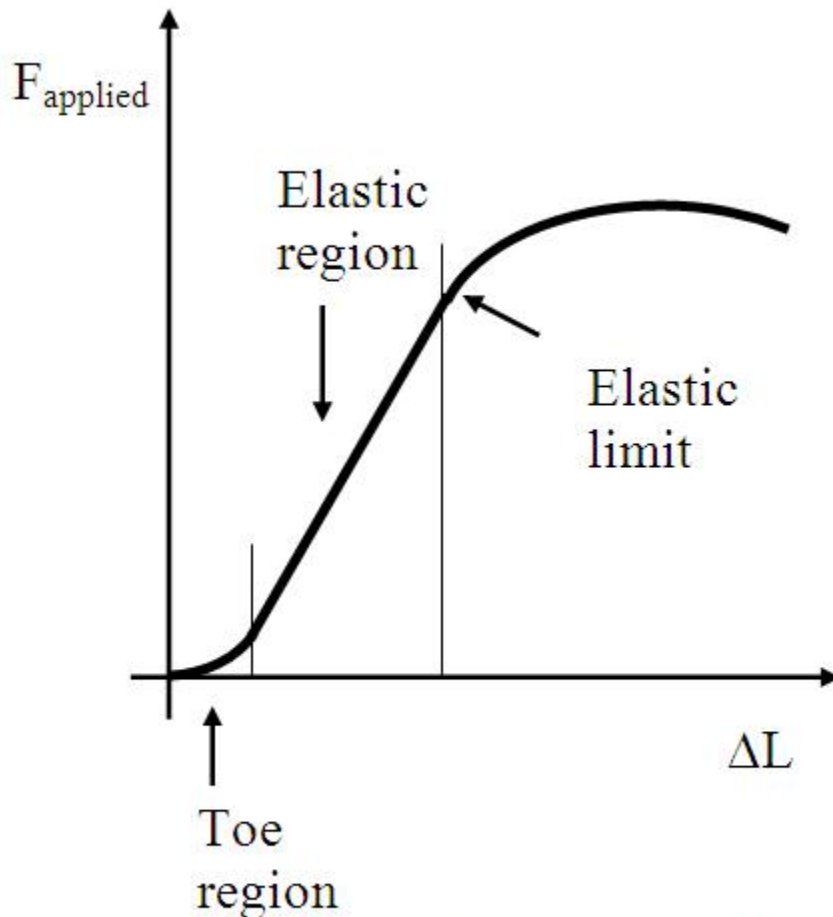

**Figure 1:** Generic force versus deformation curve with key features indicated.

The “Toe region” is the non-linear amount of “pre-stretching” an object needs to get it into the elastic realm. Anyone who has ever blown up a balloon has had experience with the toe region – you have to stretch the balloon a few times before you can easily blow it up. After pre-stretching (ie, pre-loading), additional force applied to the object shows elastic behavior. This means that there is a direct relationship between the applied force and the change in length, ie, Hooke’s Law is valid. This also means that when the force is removed, the object returns to its original shape, no matter how many times the force is applied and removed.

When the applied force is greater than the “elastic limit,” the object becomes permanently deformed. This means that when the applied force is removed, the object no longer returns to its original shape. In fact, it becomes easier to deform the object with smaller forces than when Hooke’s Law is valid. Anyone who has strained/sprained an ankle understands this phenomenon. After the first strain/sprain, it becomes easier to restrain/resprain the ankle. This is because the ligaments have been permanently deformed.



Although Force versus Deformation curves are used for many materials, it is more appropriate to examine “Stress versus Strain” curves. Stress is nothing more than the applied force divided by the cross-sectional area of the object. As more and more force is applied and the object stretches, the cross-sectional area often changes as well. That is why stress is measured, not just the applied force. In addition, the type of deformation depends on how the stress is applied. If an object is pulled, the deformation would be a change in length that is dependent on the original length,  $L$ . In this case, the strain (amount of deformation) is  $\Delta L/L$ . If the object is compressed, like squeezing a balloon filled with air, the amount of deformation would be related to how much the volume changed compared to the original volume.

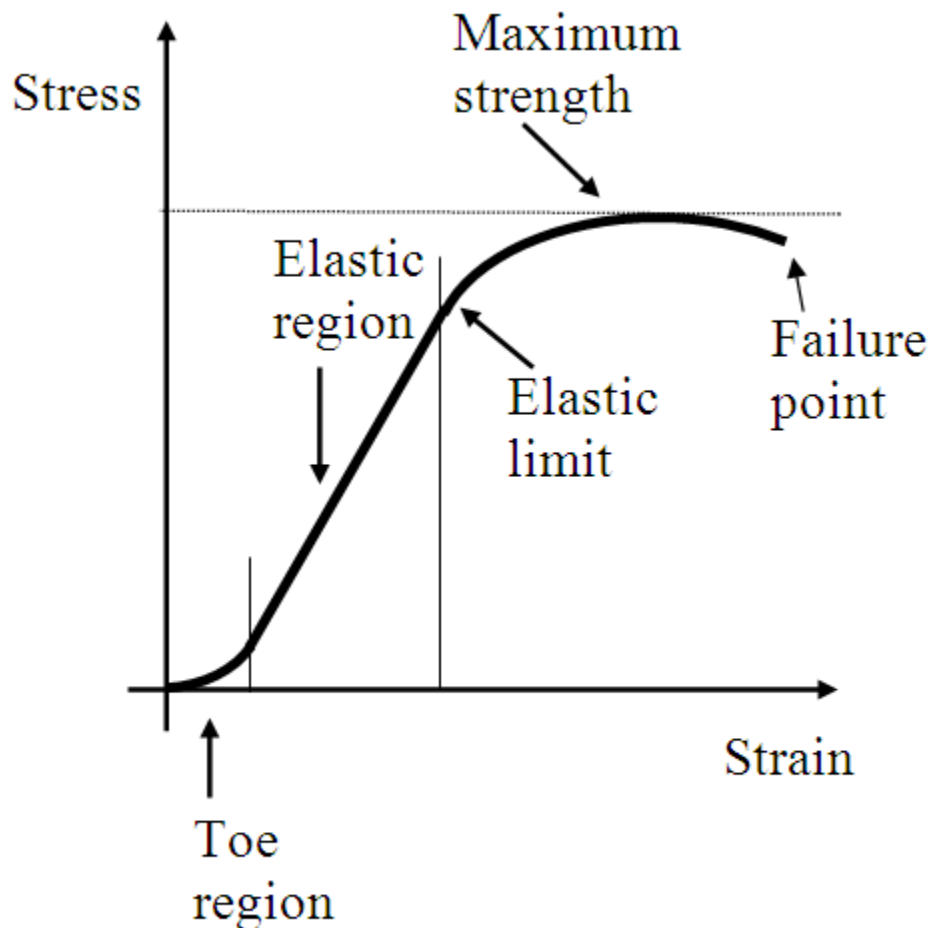

**Figure 2:** Generic Stress versus Strain curve with key features indicated.

Even though the measured quantities change from force and length to stress and strain, the resultant curves are similar, as shown in Figure 2. Two additional features are shown: the maximum strength and the failure point. The maximum strength (or ultimate strength) is the maximum stress that can be applied to the object. Any stress greater than this can result in the

object failing OR the object continuing to deform even when the stress is removed. The exact shape of a stress-strain curve depends on the properties of the material.

For most materials, it is important to know the elastic limit so that you don't permanently deform the material and/or run the risk of increasing the odds for failure (when the material no longer works as you want it to). Engineers use this information when designing or constructing products, be it a building or electronics. Medical professionals use this information when planning surgical repair with pins or plates, or during physical therapy, and more.

Before proceeding to the activities below, here are some online references that might be useful in providing additional background information. Other articles or information can be found using the search phrase "stress strain curve."

[http://en.wikipedia.org/wiki/Tensile\\_strength](http://en.wikipedia.org/wiki/Tensile_strength)

An overview of tensile strength (the stress-strain behavior of an object under tension) at Wikipedia.

<http://www.biomedcentral.com/1471-2474/3/3>

This online biomedical article, "Modeling of failure mode in knee ligaments depending on the strain rate," by Mija Lee and William Hyman, contains some stress-strain curves for ligaments and bone. The article also goes into some experimental details (a bit tedious at times).

<http://www.stclaircollege.ca/people/pages/fperissi/bt200g/week5/week5.htm>

A decent overview of the Biomechanics of Injury and the class notes for a lecture of the same name.

<http://www.shoulderdoc.co.uk/article.asp?section=419&article=1029>

This 2007 article by Lennard Funk, "Tendon Healing Mechanobiology," provides information about the tendon and the healing process, from a materials perspective. Shoulderdoc.co.uk is a website entirely devoted to shoulders.

## **MATERIALS**

- Springs or spring-like materials
- Other equipment needed to conduct the experiment (to be determined by each group)

## **ACTIVITIES**

Design an experiment to determine the elastic limit for the material provided. Represent this graphically.

# Quick Guide to Volume, Density, and the Buoyant Force

## Introduction

*Density* is something that affects many of our everyday decisions. Consciously or not, we make mental calculations of density every time we interact with the physical world around us. Can we slide that box? Can we lift that rock? This lab examines some of the ways density effects our everyday lives.

People are often confused about the difference between weight and density. There is an old riddle which highlights this confusion: "What weighs more – a pound of feathers or a pound of lead?" The answer, of course, is that both weight same - one pound. However, feathers are much less dense than lead, and therefore take up much more space. Density is the ratio of an object's mass to its volume. This means that to find density, you must measure an object's mass and divide it by the amount of space it takes up. The standard units of density are  $[\text{kg}/\text{m}^3]$ , although other units are commonly used such as  $[\text{g}/\text{ml}]$ ,  $[\text{g}/\text{cm}^3]$ , or  $[\text{kg}/\text{l}]$ . 1 ml has the same volume as  $1 \text{ cm}^3$ .

## PRELAB QUESTIONS (to be checked off at the beginning of lab)

1. What two things do you need to know about a sample if you are to determine its density?
2. What does density measure?
3. If you measured the density of a nail on the earth and then on the moon, would the densities vary? Why?
4. If you measured the density of a gallon of water and then a teaspoon of water, would the densities vary? Why?
5. Consider the concrete blocks below. A) Which has the greatest volume? B) The greatest density? C) the greatest mass? Explain your answers.
6. Consider the balloons below. These balloons were the same size, but the second one has gotten smaller due to a change in temperature. A) Which has the greatest volume? B) The greatest density? C) the greatest mass? Explain your answers.
7. If a submerged object displaces water, how is the volume of water displaced related to the buoyant force acting on the submerged object?

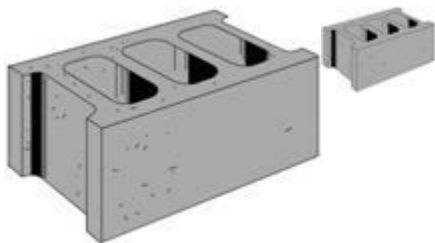

to the buoyant force acting on the submerged object?

## MATERIALS

- Water
- Force Probe
- Various objects
- Mass balance
- Graduated cylinder or beaker
- Plastic ruler
- Vernier force sensor

## ACTIVITIES

### Activity 1: Examining the graduated cylinder

The purpose of this activity is to examine the relationship between milliliters and cubic centimeters. Using your plastic ruler, make the appropriate measurements show that the ml markings on the glass do correspond with a calculated volume of  $\text{cm}^3$ . Use the shorter glass beaker for this activity, then set it safely out of the way.

### Activity 2: Finding the density

The purpose of this activity is to find the density of several objects two different ways. Mass each object provided. Use the plastic ruler to determine the volume of each. Use this information to determine the density. Next submerge each object in the graduated cylinder and make note of the volume displaced. Again, use this information to determine the density.

### Activity 3: Buoyant Force

The purpose of this activity is to graphically determine the density of water using the equation for buoyant force. Buoyant force ( $F_B$ ) is the force that a fluid exerts on an object placed in the fluid. For instance, water helps support swimmers so they feel 'lighter' than they would on land.  $F_B$  is an upward acting, contact force between the object and the fluid. The easiest way to explain  $F_B$  is Newton's 3rd Law: the object pushes down on the fluid, causing it to move aside (as seen when the fluid level rises). In response, the fluid pushes back. The more the object is immersed in the fluid, the more the fluid pushes back, until the object is totally submerged. When submerged, the maximum amount of fluid is displaced. If the fluid is denser, then it becomes more difficult to push the fluid aside. All of these factors can then be summarized by the following relation:

$$F_B = (\rho_{\text{fluid}})(g)(V_{\text{displaced}})$$

where  $\rho_{\text{fluid}}$  is the density of the fluid the object is immersed in,  $g$  is a constant (.00980 N/g on Earth), and  $V_{\text{displaced}}$  is the amount of fluid moved aside to accommodate the object.

<b>Table of Common Densities</b>	
<i>Material</i>	<i>Density (g/cm<sup>3</sup>)</i>
Water at 4 °C	1.00
Water at 20 °C	0.998
Sea Water	1.025
Magnesium	1.7
Aluminum	2.7
Copper	8.3 - 9.0
Gold	19.3
Zinc	7.14
Lead	11.3
Ice at 0 °C	0.92
Wood	0.67

Carefully study the equation. What type of equation is it? What are the constants? What parameters do you need to vary in order to model this formula graphically?

One way to acquire the needed data by slowly dipping an aluminum cylinder attached to a force probe or a triple-beam balance into a graduated cylinder. As the volume of displaced water increases, so does the buoyant force. This causes the tension in the string to decrease. If you are using a Vernier force sensor, be sure to calibrate it!

***Calibrating the force sensor:***

*Plug the Vernier Force Sensor into the LabPro. Power up the LabPro and connect it to the PC. Open Logger Pro. If the sensor is not automatically detected, click the 'Lab Pro' button. A picture of the interface box will appear. From the lists of sensors, find the Vernier Force Sensor and drag it to the button that represents the appropriate slot. Select the calibration option in Logger Pro and remove all force from the sensor. Enter 0 as the first known force. Now apply a known force to the sensor. The easiest way to do this is to hang a labeled mass from the hook on the end of the sensor. Enter the weight of the mass (note: 1 kg applies a force of 9.8 newtons).*

Using Logger Pro, generate a graphical representation of your data that will model the buoyant force equation and allow you to determine the density of the fluid from your graph. What is the meaning of the y-intercept? Compare the fluid density you found graphically with the accepted value (see the table above) using percent error. Print this graph.

**POSTLAB QUESTIONS**

1. Each measurement you made in Activity 1 should have its own associated uncertainty,  $\delta$ , which should be recorded in your data section. Use this information to propagate the uncertainty in your density calculations (see Appendix D). Compare

- your calculated density with the accepted value found in the table. Is your uncertainty of measurement enough to explain the differences? If not, discuss other sources of experimental error. For each object, discuss the pros and cons of both methods of determining density (geometric calculation and water displacement). Include this as part of your error analysis.
2. A big barge full of iron floating on a lake develops a leak and sinks. Does the water level of the lake go up, down, or stay the same? (Hint: Think about how much water the barge is displacing in each case.)
  3. A block of wood with a large iron weight on top of it floats on water. Suddenly it rolls, with the iron weight going underneath but the entire thing still floating. Is it now displacing more water, less water, or the same amount of water? (Hint: What is the buoyant force in each case?)
  4. It is difficult to find the volume of an irregularly shaped object, e.g. an intricate golden crown. First of all, it is very difficult to determine the volume geometrically. Secondly, it is difficult to attain great precision by observing a change in water level. As observed in the density activity, the density of an object may be determined by measuring its geometric volume or by measuring the volume of water it displaces. However, if this volume cannot be determined to any great accuracy, then how can one accurately determine the density of an object?

Archimedes, according to legend, solved this problem while in the bathtub. His solution is called the “Archimedes Principle.” King Hieron had provided a quantity of pure gold to a smith to make into a crown. When the crown was complete, the king suspected the goldsmith of stealing some of the gold and substituting some other metal. The crown weighed the same as the original measure of gold, so Archimedes needed to know the density of the crown in order to determine whether there had been any foul play. He knew that the volume of the crown was equal to the amount of water it displaced, but needed a more precise method of measuring the volume of the crown or of the displaced water. He did, however, know to great precision the density of water and the density of gold. While pondering this in the bath, Archimedes suddenly realized that he didn’t need to know the volume. He only needed the buoyant force! Since Archimedes was able to measure weight much more accurately than volume, this was very good news indeed!

Like Archimedes, determine the density of the aluminum cylinder using only the buoyant force, gravity, and the known density of water. Remember, you are not allowed to directly measure the volume of the cylinder or of the displaced water! This can be very tricky, so ask your instructor for help if you can’t figure it out. Using percent error, compare your calculated density with the accepted value found in the table.

# QuickGuide to Pressure, Volume, and Temperature

## Introduction

Thermodynamics is the study of the conversion of heat energy into other forms of energy, and vice versa. There are three major parameters that we often study when experimenting in thermodynamics.

**Pressure** is the force per unit area applied to the surface of an object. Its unit is one Newton per square meter, also called the Pascal (Pa). The standard atmosphere is a constant 101325 Pa (this is the atmospheric pressure at sea level).

**Volume** is the amount of three dimensional space an object occupies. Its unit is one cubic centimeter ( $\text{cm}^3$ ), or one milliliters (mL). Volume and pressure are a conjugate pair, which means that as one goes up, the other goes down.

**Temperature** is an indicator of how hot or cold an object is. It is measured on the Celsius scale ( $^{\circ}\text{C}$ ). When two objects are brought into thermal contact, temperature difference ( $\Delta T$ ) determines the direction of the energy transfer from one object to the other. The direction of the transfer is always from hotter object to the cooler object. The transfer will continue until the objects have reached thermal equilibrium, which means that they are the same temperature. The greater the temperature difference, the greater the rate of change. Because of this, the transfer occurs at an inverse exponential rate, changing quickly at first then more slowly as the temperature difference between the two objects becomes smaller.

Pressure, volume, and temperature must all be considered when making a prediction about the state of an object (solid, liquid, gas, or plasma). For example, at the standard atmosphere and volume, water will transition from its liquid state to its gas state at  $100^{\circ}\text{C}$ . However, because of the elevation of Boone, the atmospheric pressure is lower than at sea level, causing water to transition between its liquid and gas states at a lower temperature.

Transition between phases is accomplished by an energy transfer. For example, when water is heated, the input energy allows the water molecules to make the transition from its liquid to its gas state. However, the energy expended as the water molecules escape the attractive forces of the liquid results in a decrease in the water temperature. Because of this give and take of energy, the average water temperature will not change even though it is continuously heated. By the same principle, it is possible to cool an object through evaporation.

Density, elasticity, plasticity, viscosity, conductivity -- these are only a few examples of properties that change with temperature. Depending on the type of material being tested, these changes can be large or small. For example, copper will expand at a greater rate than steel while undergoing the same temperature change. Some objects, such as rubber, contract when heated. Change of phase often results in a dramatic change in the properties of the material. For example, there is a great increase in density as a gas transitions to a liquid.

## OBJECTIVES

By the end of this lab period, you should have gained a working knowledge of the relationship between pressure, volume, and temperature. After carefully recording your observations of various relevant phenomena, you should be able to develop a physical explanation for what you observed. You should also be able to describe what takes place during a phase change from solid to liquid, or liquid to gas, and knowledgeably discuss other applications of thermodynamics as well.

Another objective of this lab is to practice being a good observer. Put detailed observations into your laboratory manual, and that will make your job easier when you begin turning to outside sources in order to explain observed phenomena. For each activity, write a complete explanation into your laboratory manual of the physics behind the effect, and carefully reference each outside source.

## ACTIVITIES

**SAFETY: THIS LAB INCORPORATES THE USE OF FIRE AND LIQUID NITROGEN. GOGGLES MUST BE WORN AT THESE STATIONS, AND MITTS WHEN NEEDED! BE SURE TO CLEAR THE AISLES OF ALL LOOSE ITEMS!**

For each of the below activities, carefully record your observations. As you move from station to station, please be courteous and allow the group in front of you to finish before moving to their station. Only one group at a time should be at each station! Carefully record your observations of each physical phenomena. Once you have completed the activity, use information in the introduction, your book, or an online source to explain the physics behind what you have observed. Cite your references clearly. Draw diagrams and print graphs if needed. Make sure you are able to fully explain what is happening!

### Activities at your table

#### Activity 1. Phases: Solid to liquid

Connect the standard temperature probe to the LabPro, and set the data collection to 15 minutes at a rate of 30 samples per minute. Go to the QuickGuide to the Vernier Temperature Probe to set the calibration of the thermometer. Fill the beaker half full of water and then dump in a few handfuls of ice. Stir the ice with the temperature probe for about a minute to let it come to equilibrium before clicking "collect." When you start collecting, turn the hot plate on high and stir continuously for the entire 15 minutes or until the water reaches around 50 degrees Celsius, making note of the point at which the ice melts. Print this graph. Study about the phase change of ice to water in order to explain this effect.

#### Activity 2. Rate of cooling

Allow the water in the beaker to come to a boil. Connect two probes simultaneously to the LabPro, and set the data collection to 20 minutes at a rate of 15 samples per minute. Go to the QuickGuide to the Vernier Temperature Probe to set the calibration. Insert one of the probes into boiling water from the steam pot, and the other into hot water from the sink. After about a minute, turn off the steam pot. Click "Collect" and remove both temperature probes from the water, allowing them to dangle in the open air. The graph will show the rate



of cooling of each. Discuss the curve of each probe. What type of curve is this? Try a few different curve fits to see which works well. Print this graph. Discuss the reason the probes dipped below room temperature before coming to equilibrium. Study about Newton's Law of Cooling and evaporative cooling in order to explain this experiment.

### **Activities requiring the use of liquid nitrogen**

#### Activity 3. Phases: Liquid to gas

Spoon a small amount of liquid nitrogen into a coffee can. Put the lid on the can. Be careful! Record your observations. Measure out around 25 ml of liquid nitrogen. Pour this into a bottle and quickly slip a balloon over the mouth of the bottle. Determine the change in volume of nitrogen as it changes from a gas to a liquid.

#### Activity 4. Balloon in Liquid Nitrogen

Place an inflated balloon into liquid nitrogen for a minute, then remove. Explain how this experiment examines the relationship between pressure, volume, and temperature.

### **Other Activities**

#### Activity 5. Pressure Gauge.

A. Run hot water over a constant-volume bulb while watching the attached pressure gauge. Next run cold water over the bulb, and finally dunk the bulb in ice water. In each case, measure the temperature of the water and the pressure inside the gauge. Return to your table and make a graph which examines the relationship between the change in temperature and the change in pressure. Study about Charles' Law in order to explain this experiment.

B. Disconnect the pressure gauge from the bulb and connect it to the syringe. Note that it is a quick-connect, and the sleeve must be pulled down when the connector is inserted. Ask your instructor for help if needed. The volume is marked on the syringe. Carefully observe what happens to the pressure inside the gauge as the volume of the syringe is decreased. Take 5 measurements of syringe volume and corresponding measurements of gauge pressure. Return to your table and make a graph which examines the relationship between the change in volume and the change in pressure. Study about Boyle's Law in order to explain this experiment.

#### Activity 6. Heated metal

A metal ball fits into a metal ring. Heat the ball with a torch for about a minute and then try to fit it through the ring. Record your observations and explain. A strip of copper and a strip of steel are fastened together to make one strip. Alternatively cool and heat the strip. Be sure to douse the metal to cool it after you heat it! Study about thermal expansion in order to explain this experiment.

### **Interactive lecture demonstrations**

#### Activity 7. Collapse the can

Using the tongs, your instructor will heat an aluminum can with containing about an inch of

water over a burner until the inside of the can is totally filled with steam. You'll see the steam coming out the top of the can when it is ready. The can is then quickly inverted into a bowl of water so that the mouth of the can is totally submerged. Study about the phase change of steam to water and about atmospheric pressure to explain this experiment.

#### Activity 8. Balloon in a vacuum

Your instructor will place a small, partially-inflated balloon into a vacuum chamber and turn on the pump. Study about atmospheric pressure to explain this experiment.

### **POSTLAB QUESTIONS**

1. In activities 4 and 8, has the amount of air inside the balloons changed? Has the density of each balloon changed? Explain
2. According to your experiment, which has a greater coefficient of thermal expansion -- steel or copper? Explain.
3. Look up a coefficient of thermal expansion table to explain why steel and nickel would be a poor choice of metals to make a bimetallic strip from.
4. Discuss the difference between Charles' Law and Boyle's Law. Which law best describes what happened in activity 4?
5. Summarize Newton's Law of Cooling
6. Explain why air must be added to a car's tires to compensate for cold weather.
7. A ping-pong ball that has been dented can often be restored by placing it in hot water. Explain why this works.

## QuickGuide to the Vernier Temperature Probe



The Stainless Steel Temperature Probe is a rugged, general-purpose laboratory temperature sensor. It is designed to be used as you would use a thermometer for experiments in chemistry, physics, biology, Earth science, and environmental science. Note: Do not completely submerge the sensor. The handle is not waterproof.

### Activity 1: Measuring temperatures

Plug the temperature probe into the LabPro. Power up the LabPro and connect it to the PC. Open Logger Pro. If the temperature probe is not automatically detected, click the 'Lab Pro' button. A picture of the interface box will appear. From the lists of sensors, find the temperature probe and drag it to the button that represents the appropriate slot. Close this window.

If an accurate temperature probe is handy, or if you just want to synch multiple probes, perform a one-point calibration. Under the experiment menu, go to "calibrate." Select "One Point Calibration," and put a check mark by both probes. In the input box, enter the value of the accurate thermometer or one of the thermometers connected to the LabPro, then click "Keep." When you close this dialogue box, the thermometers should refresh to reflect this calibration.

Either read the temperature values from the lower left you the Logger Pro screen, or click "collect" for real-time temperature tracking. Experiment with the probe under your arm; in cold water; in hot water; etc.

### Activity 2: Combining hot and cold water

Go to the sink for a container of cold water and half a container of hot water. Use a pan balance to determine the mass of the water in each container. Remember to subtract out the mass of the container itself! Now use the temperature probe to measure the hot and cold water temperatures. What do you think the final temperature will be when you mix the hot and cold water in one container? Test your hypothesis by pouring the hot and cold water into one container, then stirring with the temperature probe until equilibrium is reached.

# QuickGuide to Specific Heat

## INTRODUCTION

Heat (symbolized by  $Q$ ) is a form of kinetic energy produced by the motion of atoms and molecules and is transferred from one body or system to another due to a difference in temperature. This energy is transferred from a hotter object to a cooler object. In order for energy to be conserved, the amount of heat energy lost by the hotter object must be equal to the amount of heat energy gained by the cooler object.

The amount of heat energy an object can absorb or release ( $\Delta Q$ ) is directly related to the following factors: how much mass the object has, how easy/hard it is for the material to absorb/release heat energy (otherwise known as the *specific heat* =  $c$ ), and how much the object's temperature changes ( $\Delta T$ ).

The *specific heat* ( $c$ ) indicates amount of energy (in J) required to raise the temperature of 1 kg of something by 1 degree Celsius. [An alternate set of units for  $c$  is the amount of energy (in cal) to raise 1 gram of something by 1 degree Celsius.] The specific heat is a property of the material and every substance has a different specific heat. It takes a different amount of energy to raise the temperature of 1 kg of each material by 1 °C. More energy is required to increase the temperature of a substance with high specific heat than one with low specific heat. For example, the specific heat of water is 4190 J/kg °C. This means that it takes 4190 Joules to raise the temperature of 1 kg of water by 1 °C. In fact, water is one of the more difficult materials to change the temperature of. A short list of specific heat values is included in Table 1.

Sometimes a substance can lose or gain enough energy to cause it to change state. This energy is called the *latent heat*. The heat required to change a substance from a solid to a liquid and back is called the *latent heat of fusion*, and the temperature this happens at is called the melting point. The heat required to change a substance from a liquid to a gas and back is called the *latent heat of vaporization*, and the temperature this happens at is called the boiling point. This is usually measured in terms of energy per unit mass, for example J/mol or kJ/kg.

## OBJECTIVES

The main objective of this laboratory is to give you experience with the transfer of heat energy from one object to another. One way to test if you have accomplish this is for you to accurately predict temperature changes due to heat transfer, and to accurately predict the specific heat of a material. Last of all, we hope you will be able determine the latent heat of vaporization of a fluid (liquid nitrogen).

One secondary goal includes testing your ability to set up the experiment in such a way that error is minimized, and so you should write at length in your notebook what steps you took to reduce the obvious error due to heat loss (via multiple outlets).

**PRELAB QUESTIONS**

1. If you have 1.0 g of water and 1.0 g of aluminum both at 20.0 °C, which would need to receive more energy to increase its temperature to 21.0 °C? Explain.
2. If you have 1.0 g of water and 10.0 g of aluminum both at 30.0 °C, which would need to absorb more energy to increase its temperature to 31.0 °C? Explain.
3. If you mixed .150 kg of water at 20.0 °C with .150 kg of water at 40.0 °C, what would be the temperature of the mixture?
4. If you mixed .225 kg of water at 15.0 °C with .125 kg of water at 45.0 °C, what would be the temperature of the mixture?
5. You have .070 g of an unknown sample that is at 45.0 °C. You drop it into a .150 g of water that is at 15.0 °C. After a few seconds, the temperature of the water stabilizes at 16.5 °C. Which of the materials in Table 1 is the unknown sample most likely to be?

**MATERIALS**

Styrofoam container	Two beakers
Samples	Thermometer
Mass balance	Steam pot or Hot plate

**ACTIVITIES**Activity 1: Heat Transfer between like objects of different mass and different temperature

Draw unequal masses of hot and cold water from the sink. Based on their initial temperatures, mathematically predict the final temperature of the mixture. Your instructor must check off your prediction before you continue. After your prediction has been checked, make updated measurements of the initial temperatures and record them. Now mix the water into one container, stirring until equilibrium has been reached. Was your prediction correct? If so, compare your measured value to your prediction using percent difference and continue to Activity 2.

If not, consult with your instructor or your classmates to come up with a new method of prediction. Draw unequal masses of hot and cold water again. Based on their initial temperatures, once again mathematically predict the final temperature of the mixture. Your instructor must again check off your prediction before you continue. After your prediction has been checked, make updated measurements of the initial temperatures and record them. Now mix the water into one container, stirring until equilibrium has been reached. Was your prediction correct? If so, compare your measured value to your predicted value using percent difference and continue to Activity 2. If not, continue to modify your prediction and repeat the experiment.

Activity 2: Heat Transfer between objects of different mass, temperature, and specific heat

Heat a known metal sample in the steam pot or on a hot plate. NOTE: Do not allow the sample to rest on the or sides of the container while you are heating it. As in Activity 1,

predict the final temperature of the mixture after the metal sample is placed in the Styrofoam container containing just enough water to cover the sample. Your instructor must check your prediction. Test your prediction, stirring with the temperature probe until equilibrium is reached. Was your prediction correct? If so, compare your measured value to your predicted value using percent difference and continue to Activity 3. If not, continue to modify your prediction and repeat the experiment.

### Activity 3: Determining the specific heat of an unknown metal

As in Activity 2, heat an “unknown” metal sample in the steam pot. Make the appropriate measurements to calculate the specific heat of the unknown sample. Determine what material it is made of using Table 1. If you cannot positively identify your sample, repeat the experiment.

Substance	Aluminum	Water	Zinc	Copper	Tin	Iron
c [J/kg°C]	900	4190	387	386	227	450

Table 1.

### Activity 4. Determining the heat of vaporization of liquid nitrogen

Determine the latent heat of vaporization of liquid nitrogen using hot water. Put a known mass of hot water (around 200 g) into a Styrofoam container, and measure its temperature. Into it pour a known mass of liquid nitrogen. (About half as much mass as the water should be enough). Once all the nitrogen has boiled away, measure the temperature of the water and calculate the energy required to vaporize the nitrogen. Determine the latent heat of vaporization of liquid nitrogen and compare it to the accepted value of 199 kJ/kg.

## **POSTLAB QUESTIONS**

1. For each activity above, calculate how much heat energy was transferred.
2. Calculate the percent error between the value of specific heat you calculated in Activity 3 to the corresponding value in the table.
3. For Activity 3 above, calculate the propagation of error in the final result. Include this as part of your error analysis. Is this enough to explain your calculated difference? If not, be sure to discuss other sources of error thoroughly in your error analysis (PHY 1151 ONLY).
4. What determines the direction of heat transfer when two objects at different temperatures are placed in thermal contact?
5. A metal plant stand on a wooden deck feels colder than the wood around it. Is it necessarily colder? Explain.
6. Why does your body feel cold at room temperature after you get out of the pool, even if the water was warm?

Suppose you accidentally dropped your aluminum sample into a container of liquid nitrogen. If the sample was at room temperature (around 22 degrees Celsius), how much liquid nitrogen boils away as the aluminum sample cools to -196 degrees Celsius?

# QuickGuide to Linear Thermal Expansion

## Introduction

Thermal expansion is the tendency of a matter to change in volume in response to a change in temperature. When a substance is heated, its constituent particles begin moving and become active thus maintaining a greater average separation. Materials which contract with increasing temperature are uncommon.

If the object undergoing expansion has a predominant dimension (for example, a long metal rod), it is helpful to only observe expansion in that dimension. This is called linear thermal expansion. Each material has its own coefficient of linear thermal expansion. This coefficient indicates what percentage of its original length an object will expand per degree Celsius. It is found by dividing the percent change in length by the change in temperature.

**WARNING: THIS LAB USES BOILING WATER AND STEAM! PLEASE BE VERY CAREFUL WHEN HANDLING THE STEAM POT OR THE HOT METAL!**

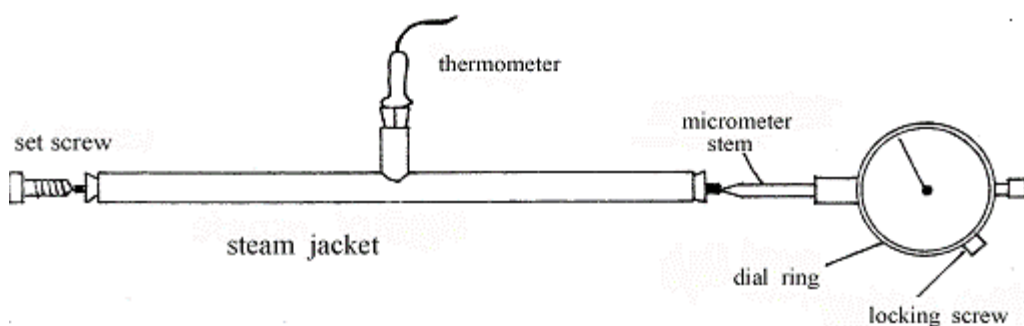

## MATERIALS

- Steam jacket
- Copper and Aluminum rods
- Steam generator
- Watch glass
- Water
- Paper towels
- Thermometer

## OBJECTIVES

1. To discover how heat affects the dimensions of different metals.
2. To learn how to use a micrometer.
3. To practice controlling variables in order to determine a physical property of a material.

## ACTIVITIES

### Activity 1: Measuring the coefficient of linear thermal expansion.

Inject steam from the steam pot into a metal jacket that encloses a metal rod of a known length. The rod should be held loosely in the jacket by two rubber stoppers, and should be firmly abutting the set screw on one end and the micrometer needle on the other.

As the temperature inside the chamber changes due to the influx of steam, the rod should expand. Make sure the thermometer tip is in the chamber. The change in length may be measured using the micrometer. Examine the micrometer to determine the units and precision, and estimate the reading to the nearest fifth of a division.

Determine the change in temperature, and the percent change in length (stated as a decimal). Use this information to calculate the coefficient of linear thermal expansion. Locate a table of linear thermal expansion coefficients online and compare your experimental results to the accepted value using percent error. Be sure to cite your reference!

### Activity 2: Repeating for a different material

Allow the apparatus to cool sufficiently and repeat the experiment using a different type of metal rod.

## POSTLAB QUESTIONS (PHY 1151 only)

1. Measurements of three different quantities were made to determine the coefficient of linear expansion, namely the original length, the change in length, and the change in temperature. Each measurement has its own associated uncertainty,  $\delta$ , which should be recorded in your data section. Use this information to calculate the fractional error of all of your measurements and the uncertainty in your coefficient of linear expansion for both metals (see Appendix D). Include this as part of your error analysis.
2. According to Question 1, which measurement contributes the greatest error in the final result? Does this make sense? Explain your reasoning.

Is the uncertainty of measurement enough to explain the percent error in your results? If not, identify the sources of experimental error that could explain the difference between your values and the accepted values.



# QuickGuide to Static Electricity

## STATIC ELECTRICITY

### Introduction

All objects consist of atoms that are made up of electrons, protons, and neutrons. Electrons have a *negative* charge, while protons have a *positive* charge. Neutrons, as the name indicates, are *neutral*. Objects are electrically neutral when they have an equal number of electrons and protons so that the total charge is zero. Since most objects are electrically neutral, the only way to have a charged object is to add or remove electrons as they are not part of the nucleus and are therefore easier to move around than protons.

### MATERIALS

- Scotch tape
- Styrofoam pie plate
- Styrofoam cup and metal plate electrophorus
- Pencil, string and aluminum ball

### ACTIVITIES

#### Activity 1: Charging by friction

When you pull tape off of a roll, the tape is automatically attracted to you. Even the non-glue side will be attracted to your finger and will move toward your finger. We do not know whether the tape is charged positively or negatively, but by the end of the lab you may be able to determine the actual charge of the tape.

Remove a piece of tape off a neutral roll of tape. What evidence do you have that the piece of tape is charged? If the piece of tape becomes charged, what must happen to rest of the roll of tape? Remember that it started out neutral.

Observe the interaction between the piece of tape and the roll it was removed from. Explain this interaction. Predict the effect if a second piece of tape is pulled off the roll of tape and held near the first piece of tape. Your instructor must check off your prediction before you continue. Test your prediction. If your prediction was incorrect, explain why.

Stick your two pieces of tape together, and remove all the charge from the pair by touching them all over. Predict the effect of pulling the pieces of tape apart. Will they be charged the same or opposite to each other? Your instructor must check off your prediction before you continue. Test your prediction. If your prediction was incorrect, explain why.

On your table is a home-made electrophorus. This device will be used throughout most of the remaining activities. You must handle the electrophorus using the Styrofoam cup. Why is this important?

The source of charge for this part of the lab will be your Styrofoam plate. Charging the plate can be accomplished by rubbing the Styrofoam plate against your sweater or a seat cushion. As with the tape, we do not know whether the Styrofoam plate is charged positively or negatively (you can't always go by the diagram). By the end of the lab, you may be able to determine the actual charge of the Styrofoam plate.

### Activity 2: Charging by conduction

Charging by conduction occurs when two conducting objects touch each other. If there is a charge difference between the two of them, then charges will flow until that difference has been neutralized. It also happens when charges jump the gap between two objects, as when charges go between a cloud and the ground. In this way, non-conducting objects may also transfer charge.

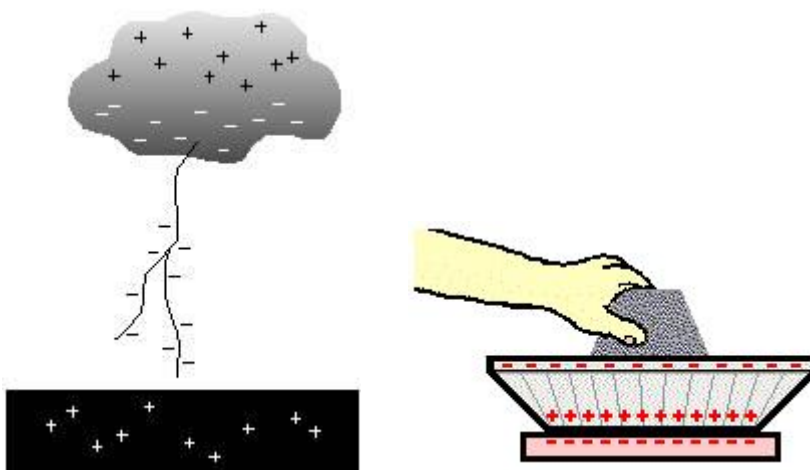

Figure 1: Charging by Conduction

This is the way charge is transferred between the surface of your Styrofoam plate and the aluminum plate of the electrophorus. When the two are close enough, the charge created by friction jumps off the Styrofoam plate onto the neutral, conducting aluminum plate. If you listen carefully, you can hear the faint crackles of “thunder” as the tiny bolts of lightning go between the two plates.

Charge up your Styrofoam plate and place it upside down on your table. Holding the electrophorus by the Styrofoam cup, place your electrophorus on top of the Styrofoam plate for a few seconds. Remove the electrophorus from the Styrofoam plate. Is the electrophorus the same charge as the Styrofoam plate or the opposite charge of the Styrofoam plate? Explain. If the Styrofoam plate and the electrophorus have the same charge, then explain why the Styrofoam plate “sticks” to the electrophorus. (To explain this, you may need to read Activity 3).

There is a small aluminum ball on a string attached to the electrophorus. Position it so that it is only several millimeters from the rim of the aluminum plate, and can easily touch the rim by swinging back and forth. Neutralize yourself by touching a grounded conductor (the back

of your computer will work well), then touch the ball and the aluminum plate simultaneously to neutralize them as well.

Charge up your Styrofoam plate and place it upside down on your table. Holding the electrophorus by the Styrofoam cup, place your electrophorus on top of the Styrofoam plate for a few seconds. Remove the electrophorus from the Styrofoam plate, making sure that you only handle the electrophorus by the non-conducting cup.

Touch the back of the computer to neutralize yourself, then bring your finger close to the hanging metal ball and push it toward the electrophorus. What do you observe? If you are unsure of the effect, ask your instructor if you are doing everything correctly. Explain the entire process, from beginning to end, using your own words and sketches.

### Activity 3: Charging by induction

Yet another way of charging is by induction. Charges can only be induced in conductors. When a charged object is brought near to a conductor, it causes the electrons in a conductor to move away from the object if it is negatively charged, or toward the object if it is positively charged. This effectively polarizes the conductor, with half of it positive and the other half negative. Even though there is a separation of charge, the object as a whole remains net neutral. However, if the object then comes in contact with another conductor, electrons will then be transferred through the conduction process, giving the object a net positive or negative charge.

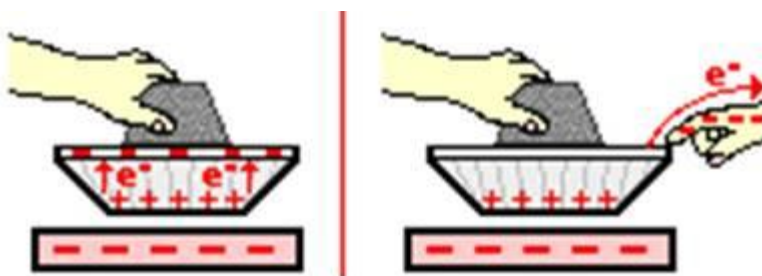

Figure 2: Charging by Induction

Charge up your Styrofoam plate again and place it upside down on your table. You will need a partner to hold the plate down, or else tape it to the table. Neutralize yourself and your electrophorus as in Activity 2. Without touching the two plates, lower your electrophorus down toward the Styrofoam plate and get them very close together but do not touch them together! You don't want charge to jump from one to the other as in Activity 2. Now by touching the top of metal plate with your finger, you can cause the metal plate to lose its neutrality and become charged (see Figure 2). Explain how this works. Is the metal plate of the electrophorus the same charge as the Styrofoam plate or the opposite charge of the Styrofoam plate? Explain. How is this different from charging by induction?

Lift the electrophorus away from the Styrofoam plate. Touch the back of the computer to neutralize yourself, then bring your finger close to the hanging metal ball and push it toward

the electrophorus. What do you observe? According to your observations, which method of charging more strongly charges the electrophorus?

Now do the experiment slightly differently. As before, neutralize yourself and your electrophorus, and then bring it near to your Styrofoam plate as if you were going to charge by induction. Then, instead of touching the aluminum plate with your finger, keep the electrophorus where it is and perform the experiment with the aluminum ball. How is this different from the previous experiment? Explain the entire process, from beginning to end, using your own words and sketches.

#### Part 4: Determining polarity

In the previous parts, there was no clear way of knowing if the plates were negative or positive, or which direction the electrons were moving. This experiment should help to answer those questions. There is a small neon light bulb attached to the electrophorus. If you look carefully at the neon light bulb you will see that there are two wires inside the bulb that correspond to the two wires outside of the bulb. When charge flows through the bulb it will light. However, only one of the wires will light up at a time. Which one lights up depends on the direction of the electron flow. The light will indicate to you which side of the bulb has incoming electrons.

Charge up your electrophorus by conduction, and then neutralize yourself. Slowly bring your finger up to the end of your light bulb. You should see one side of the light bulb light up for a split second. What is the direction of the electron flow? Based on this experiment, explain in your own words and sketches how you can know the charge of the Styrofoam plate.

Now Charge up your electrophorus by induction. Lift the electrophorus away from the Styrofoam plate and neutralize yourself again. Slowly bring your finger up to the end of your light bulb. You should see one side of the light bulb light up for a split second. What is the direction of the electron flow? Based on this experiment, explain in your own words and sketches how you can know the charge of the Styrofoam plate.

Do both charging methods verify the polarity of the Styrofoam plate? Charge up the Styrofoam plate again, then pull a piece of tape off the roll and bring it near to the plate. What is the polarity of the piece of tape? Explain your reasoning.

# QuickGuide to Equipotentials and Electric Field lines

## Introduction

The intervening space between oppositely charged electrodes contains an electric field. Lines which have the direction of the electric field at each point in space are called *electric field lines*. They can never cross or touch and they begin on the positive electrode and end on the negative electrode. The direction of the electric field is always from positive to negative. Work is done on an electric charge as it is moved along by an electric field, and each point on a path will be at a certain definite electric potential with respect to one of the electrodes. All the points of the same electric potential form an *equipotential line*. Like electric field lines, these can never cross or touch each other. No work is done on a charge that moves along an equipotential line. Since maximum work is done on a charge that moves along an electric field line, equipotential lines always intersect electric field lines at right angles.

Since a good conductor has a uniform potential throughout its volume, there is no electric field inside of it. Electric field lines will always terminate perpendicular to the surface of a conductor.

Does all this seem confusing? By performing this experiment, you should be able to acquire a qualitative idea of electric fields and equipotential lines in two dimensions when using various electrode configurations.

## MATERIALS

- Tray with plastic grid
- Voltmeter with probes
- Metal tray
- Various electrodes and connectors
- Graph paper (4 sheets)
- Water
- Colored pencils or highlighters

## ACTIVITIES

YOU ARE CAUTIONED AGAINST PERMITTING YOURSELF TO BECOME PART OF AN ELECTRICAL CIRCUIT AS THIS MAY BE INJURIOUS TO YOUR HEALTH. FOR ALL ELECTRICAL EXPERIMENTS, DO NOT CONNECT LEADS TO ANY VOLTAGE SOURCE UNTIL YOUR CIRCUIT HAS BEEN CHECKED BY YOUR LABORATORY INSTRUCTOR.

To the tray add around 400 ml of water. This should be enough to cover everything with a thin layer of water and still be shallow enough that the electric field will be roughly two-dimensional. A plastic grid is placed in the tray so that the positions of the various electrodes may be located on the graph paper on which the plots are made. Lift up one edge of the plastic and let it down slowly to remove all air bubbles. One student should manipulate the

voltmeter probe and call out the readings to another student who plots the readings on a piece of graph paper. The graph paper is similar to the plastic grid and should be labeled with the same scales. This enables one to call the probe positions to his/her partner without confusion.

#### Activity 1a: Predict Dipole Electric Field:

Place the point electrodes about 6 inches apart in the water and record their positions on your graph paper (do not use the copper strips for this part). Do not power the circuit yet! Based on the information given in the introduction, sketch (on a blank sheet of paper) your prediction of the electric field showing the direction of the field lines. Label your prediction "**A-1: Prediction of Dipole Electric Field**". Your instructor must check your circuit and this prediction before you power your circuit!

#### Activity 1b: Experimental Determination of Dipole Electric Field:

Connect the circuit so that there is a voltage difference between the two point electrodes. Using the voltmeter set on DC volts, measure the voltage between the two electrodes. Place the "- voltage (ground)" probe on the negative electrode so that the voltmeter reads a positive voltage. With the "ground" probe still attached to the negative electrode, submerge your "+ voltage" probe in the water. Keeping the probe vertical, slowly move it through the water from the negative electrode to the positive electrode, watching the voltage change along the way. Now see if you can move your probe so that it follows a line of equal potential. In other words, pick a voltage and slide your probe slowly so that as the probe moves through the water, the voltage does not change. The line you are tracing is an equipotential line. As you trace this line, call out coordinates to your lab partner so that a corresponding line may be drawn on the graph paper. Remember to move very slowly; watching the voltmeter to make sure that the voltage remains the same. Trace the complete equipotential line. After this line has been drawn, choose a different voltage and begin tracing a new line. You are going to trace at least 5 equipotential lines, so try to choose voltages that are evenly spaced, giving you a complete picture of the electric field gradient. When you are finished, go over these lines with a colored pencil or highlighter so that all the equipotential lines are the same color. Make sure each line is labeled with the voltage measured along it!

The next step is to draw in the electric field lines. Read the introduction carefully to determine how the electric field lines behave as they intersect lines of equipotential and the surfaces of the conductors. Plot a series of evenly-spaced equipotential lines that will give you a good idea of the shape of the electric field. When you are finished, go over these lines with a colored pencil or highlighter so that all the electric field lines are the same color, but different from the equipotential lines. Be sure to indicate the direction of the electric field. Label this graph "**A-2: Experimentally Determined Dipole Electric Field**" and include a legend showing what the color of each line represents.

#### Activity 2: Electric field Between Parallel Plates:

Disconnect power and place a copper bar under each point electrode. Repeat your prediction of the electric field as above by drawing a sketch on a blank sheet of paper (Label it "**B-1: Prediction of Electric Field Between Parallel Plates**"). Remember to have your instructor to check off your circuit and prediction before powering the circuit! Then repeat the measurements as above and prepare a second graph ("**B-2: Experimentally Determined Electric Field Between Parallel Plates**") and legend as before.

**POSTLAB QUESTIONS**

1. Record your observations. What were the general shapes of each field? Did they match your predictions? Explain why each field is the shape that it is.
2. In your own words, describe the behavior of equipotential lines and electric field lines as they interact with conductors, insulators, and each other.
3. Imagine that instead of equipotential lines of voltage, you had plotted equipotential lines of gravitational potential energy. This would be called a topographical map, which is used by hikers, etc. to indicate to them relative elevation. If your equipotential lines were lines of elevation on a topographical map, then the electric field lines would represent the paths taken by water, e.g. rain that falls on the ground. Explain why this is a good analogy.

# Quick Guide to Electric Circuits

## Introduction

All circuits share some features: an energy/power source, like a battery; wires to connect different components/devices together; and components/devices to put into the circuit. There are as many different ways to create circuits as there are applications. These applications depend on the components/devices in a circuit.

One type of *component* (or device) is a resistor, something that “resists” the flow of charge (current). An example of a good resistor material is any type of insulator like ceramic or rubber. An example of a poor resistor material is any type of conductor like metal. There are other factors that can affect resistance, including the number of resistors and how they are connected. For a single resistor, the material and how it is constructed determine its resistance.

Other examples of components include light bulbs and capacitors. These devices can use the energy/power supplied by the battery to do different things. In the case of the capacitor, energy can be stored in the capacitor for use at another time or for another circuit. The components used in the circuits activities below provide a basic demonstration of how circuits work and their applications. Additional components (diodes, transistors, etc.) can be combined to create more complex circuits that will not be discussed in this course, but are essential for understanding how modern electronics (MP3 players, cell phones, computers, etc.) work.

## Materials

Batteries	Light bulb (lamps)
Wires	Bulb holder (light socket)
Capacitor	LoggerPro
Current probes	Voltage probes
LabPro	

## Objectives

- Design and construct simple circuits.
- Draw circuit diagrams using symbols.
- Determine how to infer information about current using light bulbs.
- Determine how to measure voltage and current.

## Activities

### Activity 1 – Make it work!

Using only one battery, one wire, and one light bulb, construct a circuit arrangement that lights the bulb. Discuss what needs to be done to light the bulb. Generate a sketch of the



circuit the results in a lit bulb AND a representative circuit for an unlit bulb. Your sketch should be understood by anyone interested in lighting a light bulb.

Explain how a light bulb works. Include a sketch of the inner workings of the light bulb.

Refer to the circuit pictograms below. Redraw the above circuits using commonly used pictograms for the light bulb, wires, and a battery. Refer to this page for future circuit diagrams.

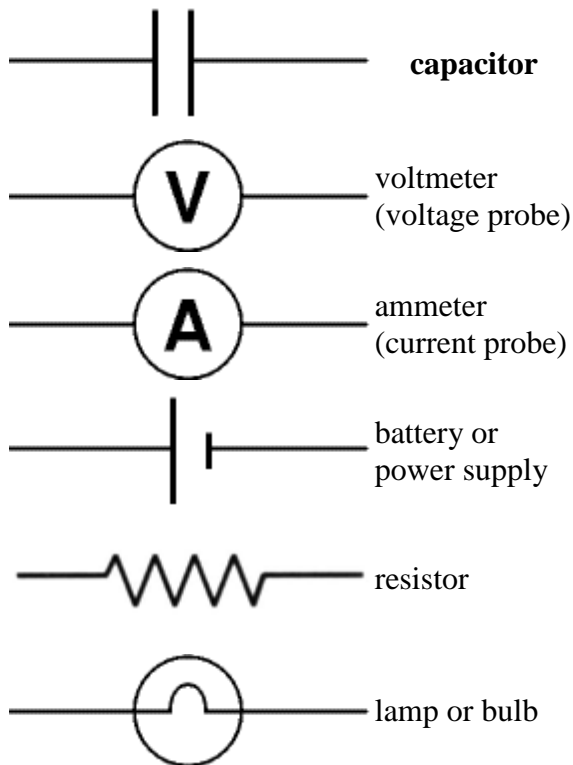

Figure 1. Electrical Symbols

Activity 2– Not very bright, is it.

Use the Current Probe to measure the current in the circuit with one bulb and one battery. Be sure to zero the probe! The current probe must be inserted into the circuit in such a way that the current you are measuring must flow through the probe (see figures 2 and 3). Examine the current before the bulb (see figure 2) and after the bulb (see figure 3). Describe how the current changes, or not, with each location.

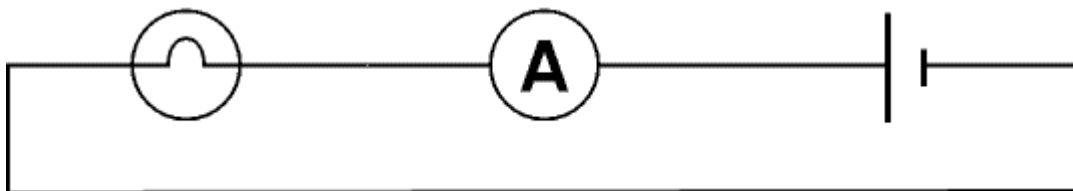

Figure 2. Current probe before the bulb.

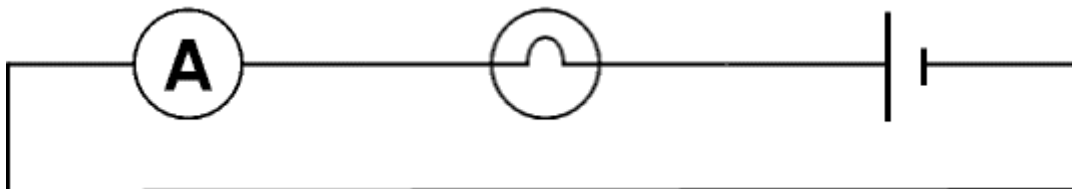

Figure 3. Current probe after the bulb.

Measure the current for the bulb connected to 2 through 4 batteries. Describe the relationship, if any, between the current and the brightness of the bulb.

Use the Voltage Probe to measure the voltage in the above circuit. Be sure to zero the probe! The voltage probe must be inserted into the circuit in such a way that it is touching the two places across which you want to measure the voltage difference (see figures 4 and 5). Connect the black probe to the negative terminal of the battery and use the red probe to examine the voltage before the bulb (see figure 4) and after the bulb (see figure 5). Describe how the voltage changes, or not, with each location.

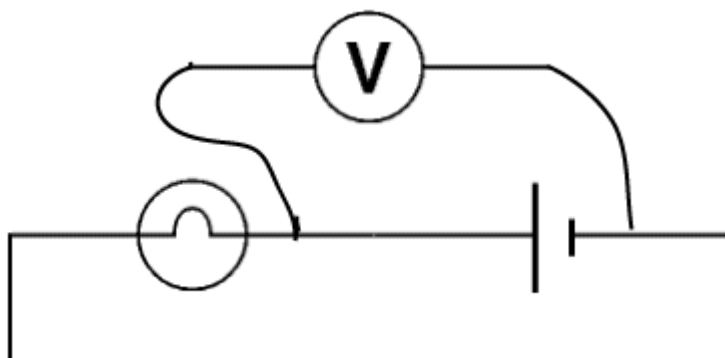

Figure 4. Voltage probe before the bulb.

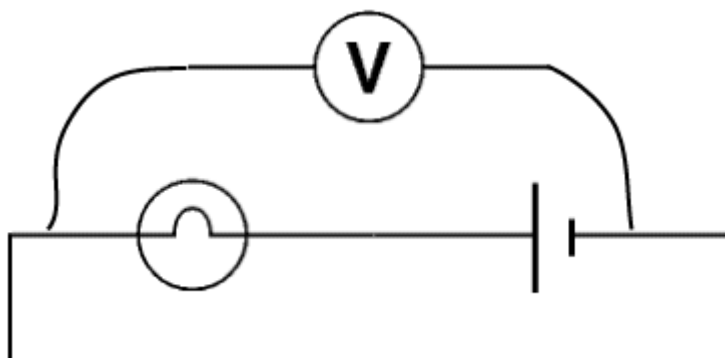
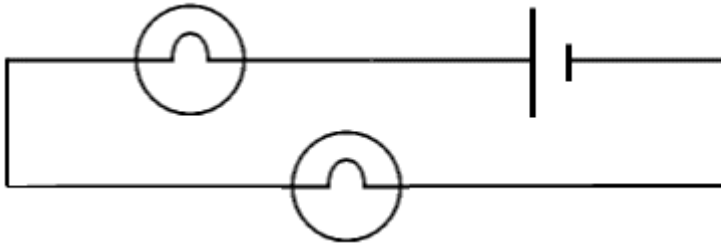

Figure 5. Voltage probe after the bulb.

Measure the voltage for the bulb connected to 2 through 4 batteries. Describe the relationship, if any, between the voltage and the brightness of the bulb.

### Activity 3 – Making connections

Connect two bulbs in series (in a row so that there is only one path for current to flow). Connect the bulbs to three batteries in series. Provide a sketch of the series circuit. Using the same batteries as part one, compare the bulb brightness of the two bulbs to when only one bulb is connected. Propose an explanation for your observations. Predict the effect of having three bulbs in series.



Borrow a third bulb from another table and quickly place it in series with the other two bulbs. Was your prediction correct? Return the bulb.

Use the current probe to measure the current of the series bulbs. Examine the current before, between, and after the bulbs. Describe how the current changes, or not, with each location. Is this different from the current when only one bulb is connected?

Use the voltage probe to measure the voltage of the series bulbs. Connect the black probe to the negative terminal of the battery and use the red probe to examine the voltage before, between, and after the bulbs. Show the locations of the voltage probe. Describe how the voltage changes, or not, with each location.

### Activity 4 – A parallel universe

Connect two bulbs in parallel (side by side so that the current must split in order to flow through both). Provide a sketch of the parallel circuit. Compare the bulb brightness to when only one bulb is connected. Propose an explanation for your observations. Predict the effect of having three bulbs in parallel.

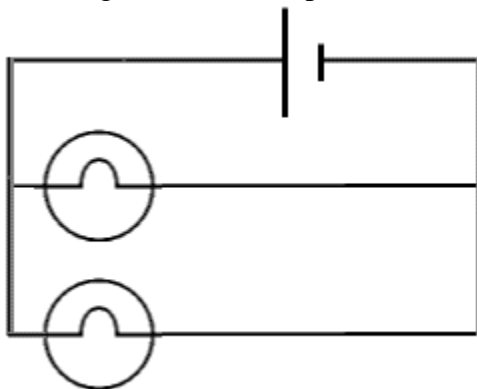

Borrow a third bulb from another table and quickly place it in parallel with the other two bulbs. Was your prediction correct? Return the bulb.

Use the current probe to measure the current of the parallel bulbs. Examine the current before the bulbs, on each individual branch of the parallel circuit, and after the bulbs. Describe how the current changes, or not, with each location. Use a sketch to show your current probe positions. Propose an explanation for your observations.

Use the voltage probe to measure the voltage of the series bulbs. Connect the black probe to the negative terminal of the battery and use the red probe to examine the voltage before the bulbs, on each individual branch of the parallel circuit, and after the bulbs. Use a sketch to show your voltage probe locations. Describe how the voltage changes, or not, with each location.

### Activity 5 – A healthy relationship

What is the relationship between voltage and current? In this activity, you will show this graphically.

Up until now, you have been using the same number of batteries for every measurement. Now, however, you will find the voltage and current using various combinations of batteries. Construct a circuit with a single bulb. Measure the voltage across the bulb and the current through the bulb using 0, 1, 2, 3, and 4 batteries. You should have 5 data points. Make a graph showing the relationship between voltage and current for the light bulb. Describe the relationship in words.

Replace the bulb with a resistor and repeat the above experiment. Make another graph showing the relationship between voltage and current for the resistor. Describe the relationship in words. In what ways is the resistor graph different from the light bulb graph?

### **POSTLAB QUESTIONS**

1. Attempt to describe, in terms of current, voltage, and bulb brightness, exactly what is going on in a series circuit. Use a diagram.
2. Attempt to describe, in terms of current, voltage, and bulb brightness, exactly what is going on in a parallel circuit. Use a diagram.

## QuickGuide to the Vernier Current and Voltage Probes



Use the Current Probe to measure currents in low-voltage AC and DC circuits. With a range of  $\pm 0.6$  A, this system is ideal for use in most "battery and bulb" circuits. Use it with the Voltage Probe to explore Ohm's law, phase relationships in reactive components, and much more. Use multiple sensors to explore series and parallel circuits. It can also be used in electrochemistry experiments.

### How the Differential Current Probe Works

The Current Probes were designed to look like they should be wired in series with the circuit. Currents in either direction can be measured. The current will be indicated as positive if current flows in the direction of the arrow on the small box (from the red terminal to the black terminal). The range is  $\pm 0.6$  A ( $\pm 600$  mA). The Current Probe connects to the amplifier box, which in turn connects to the LabPro.

### How the Voltage Probe Works

The Differential Voltage Probe measures the potential difference between the V+clip (red) and the V- clip (black). The voltage probes have differential inputs. The voltage measured is with respect to the black clip, which is connected to circuit ground. This allows you to measure directly across circuit elements without the constraints of common grounding. The voltage probes can be used to measure negative potentials, as well as positive potentials.

The voltage probes are designed to be used like voltmeter leads. They should be placed across a circuit element. The differential input range is  $-6$  volts to  $+6$  volts. Over-voltage protection is provided so that slightly higher voltages will not damage the sensor. You should NEVER use high voltages or household AC with these sensors.

### Activity 1: Voltage and current

Place the Current Probe into the amplifier, then plug the amplifier into the LabPro. Power up the LabPro and connect it to the PC. Open Logger Pro. If the probe is not automatically detected, click the 'Lab Pro' button. A picture of the interface box will appear. From the lists of sensors, find the probe and drag it to the button that represents the appropriate slot. Start

by connecting the terminals together so that no current can flow, then zeroing the sensor. The value of current is displayed in the lower left of your LoggerPro screen.

Use a variable power supply to power a resistor. Place the Voltage Probe across the resistor, and the Current Probe inline with the resistor. What happens when you vary the power supply? Are current and voltage related?

### Activity 2: Measuring Resistance

Change the axis so that the graph plots potential versus current. Click "collect." As you vary the power supply, the potential and the current are plotted in Logger Pro. According to Ohm's Law, the resistance is the slope of the potential versus current graph.

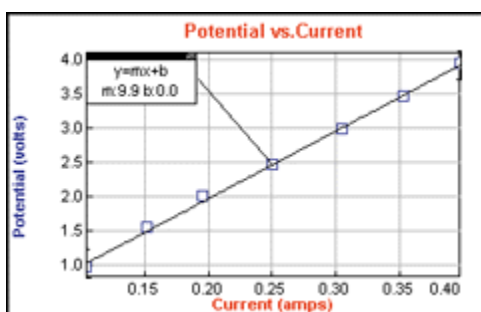

# Quick Guide to Ohm's Law

## Introduction

**Ohm's law** states that the current through a conductor between two points is directly proportional to the voltage across the two points, and inversely proportional to the resistance between them.

The mathematical equation that describes this relationship is:  $V = RI$ , where  $V$  is the voltage (or potential) measured in volts (v),  $R$  is the resistance measured in Ohms ( $\Omega$ ), and  $I$  is the current measured in Amps. If the resistance is constant over a large range of values of current and voltage, the resistor is referred to as an *ohmic device*. In this experiment, you will examine the relationship between current and voltage in both ohmic (the ceramic resistor) and non-ohmic (the light bulb) devices.

## Materials

Batteries	Light bulb
Wires	Bulb holder
Various Resistors	Lab Pro
Current and Voltage Probes	
Multimeter	

## Activities

### Activity 1 – Graphically determining resistance

The purpose of this activity is to graphically determine the resistance of two ohmic devices (two different ceramic resistors). If they are ohmic, then the resistance should remain constant over a wide range of voltages and currents. Test this by simultaneously measuring the current **through** the resistor and the voltage **across** the resistor. To do this, you will need to connect the current and voltage probes.

Set up a circuit that will allow you to simultaneously measure the current and voltage of a resistor connected to the battery pack. Draw the circuit diagram using the symbols below. With the 4-battery pack, you should be able to acquire five different voltages and currents. Using Logger Pro, plot voltage (potential) and current together in such a way that the slope is equal to the resistance.

**TIP:** Don't use "time-based" data collection. Instead, use "selected events." You can change your method of data collection by going to the "Data Collection" link under the "Experiment" menu. Remember: don't use connecting lines, show point protectors, and name each data set with a descriptive name!

After you have determined the resistance of the first resistor, repeat for a different resistor. Be sure to rotate lab partners so that a new person gets to control the computer, and a new

person also gets to build the circuit! Plot both data sets on the same graph. (See the Quick Guide to Graphing in Logger Pro (part 7) for graphing multiple data sets.)

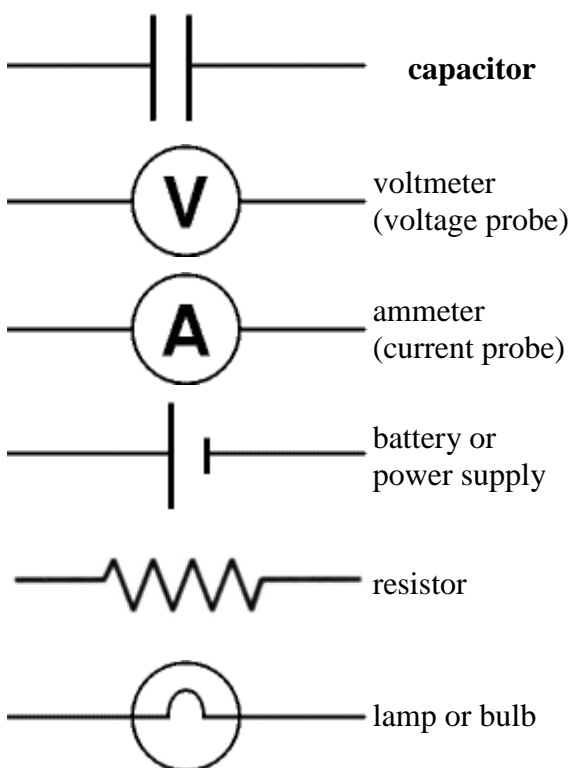

### Activity 2 – Series Resistors

Using the resistances found for the two resistors in Activity 1, calculate (predict) the total theoretical resistance of these resistors if they were connected in series.

After you have your predictions, actually connect the two resistors in series and determine the total resistance using the procedure found in Activity 1. Plot this new data set on the same graph as the individual resistors in Activity 1. (By now, there should be three lines on your one graph.) How does the series resistance found from the slope of this new line compare to your predicted value? (Use percent difference.)

Using the resistances found for the two resistors in Activity 1, calculate (predict) the total theoretical resistance of these resistors if they were connected in parallel.

After you have your predictions, actually connect the two resistors in parallel and determine the total resistance using the procedure found in Activity 1. Plot this new data set on the same graph as the individual resistors in Activity 1 and the series combination. (By now, there should be four lines on your one graph.) How does the parallel resistance found from the slope of this new line compare to your predicted value? (Use percent difference.)

### Activity 3 – A Non-Ohmic Device

Repeat Activity 1 using a light bulb. Plot this data set on a new graph. Show that the resulting



curve is more quadratic than linear (you can show more than one curve fit for a data set). According to your graph, how does the resistance of a light bulb vary as the current increases?

#### Activity 4 – Ranking Resistances

Each of the resistors below each have the same value. Collaborate with your partner to rank the configurations below in order of increasing total resistance. Explain your reasoning.

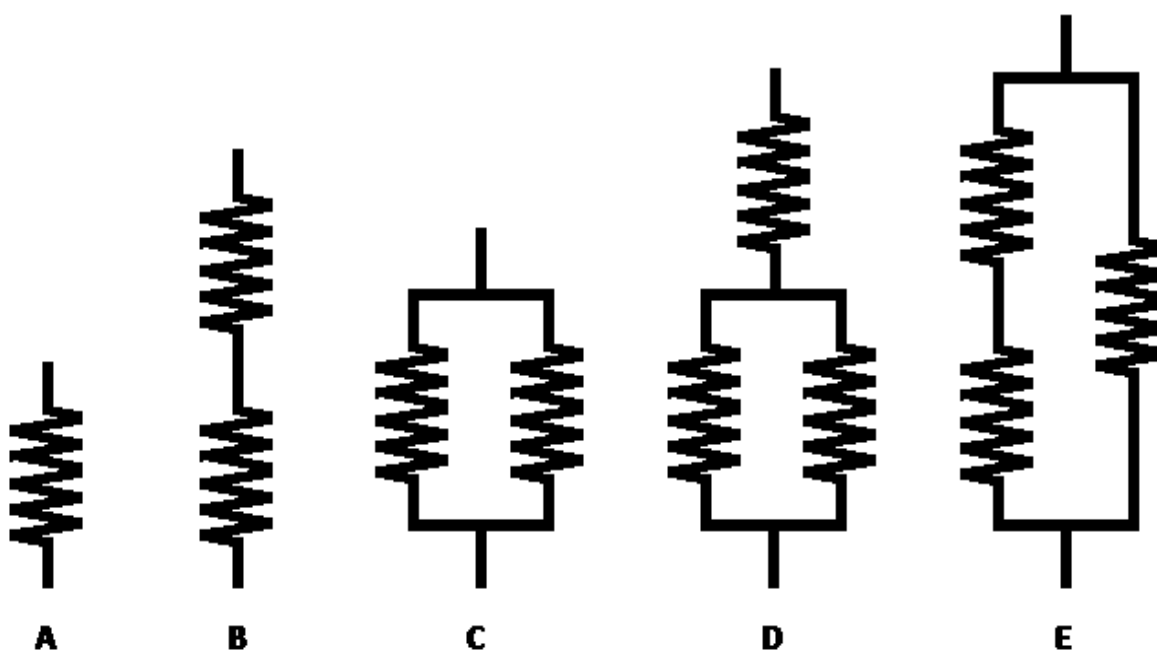

#### Activity 5 – Directly Measuring Resistance

Construct the above configurations, using up to three identical resistors. Find the resistance of each using the procedure in Activity 1. Name your data sets A through E and show all five data sets on the same graph. Was your ranking prediction correct? If not, what caused you to make an incorrect prediction?

## QuickGuide to the Lamp Bank

### BACKGROUND INFORMATION

The lamp bank is a set of light bulb sockets and light bulbs that can be used to create series and parallel circuits. One of the lamp banks should be available with the lid removed so you can see how the wires, switches, sockets, and ammeter are all attached. The circuit diagram is printed on top of the lamp bank. Keep in mind that the voltage supplying the lamp bank is on the order of 110-120 Volts AC. Touching any of the unshielded wiring or open sockets while the lamp bank is plugged in and turned on could result in an electrical shock.

When dealing with light bulbs, it is useful to know that the stamped power rating for a light bulb is based on a standard voltage. When a voltage is supplied to the light bulb, the current can be measured and the power calculated. Changing the filament of the light bulb changes the resistance of the light bulb, ultimately changing the current that can flow through the filament. [**Note:** Make sure you know how a light bulb works and how it is constructed.] Higher-wattage bulbs have thicker, shorter filaments, than lower-wattage bulbs. When the bulbs are placed in series, the voltages across the bulbs are not equal. For this reason, the lower-wattage bulbs may glow while the higher-wattage bulbs only grow warm.

Power = voltage · current

### APPARATUS

Lamp bank with ammeter  
 Standard electrical outlet  
 Collection of light bulbs with different power ratings  
 Line monitor (for voltage reading)

### ACTIVITIES

#### **Activity 1 – Lamp Bank**

To become familiar with the lamp bank and how the switches can be used to create various circuits, flip switches to create each the following circuit configurations. Make sure to write down which switches are on and which are off. Experimentally determine the total power for each of the following circuits.

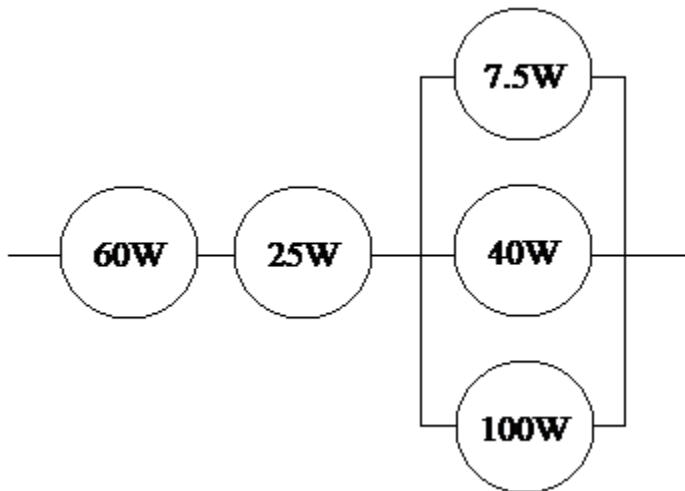

**Activity 2 – Power**

Using the stamped values of power and the measured current, design an experiment which uses the lamp bank to graphically show the equation for power. Use at least ten data points.

**Activity 3 – Equivalent resistance**

Predict the equivalent resistance of three bulbs a) in parallel; and b) in series. Design an experiment to determine the equivalent resistance of these two circuits. Make sure to compare your experimental results with your predicted values. Are they close? If not, explain why.

# QuickGuide to Capacitance

## CAPACITANCE

### Objectives

- To become familiar with RC circuits;
- To practice constructing an electronic circuit and making voltage measurements;
- To interpret the voltage versus time graph of a charging and discharging capacitor;
- To observe how capacitors add in series and parallel;
- To predict the behavior of an RC circuit.

### Introduction

Capacitance (C) is measured in Farads (F). The Farad is the ratio of the electric charge (Q) on each plate to the potential difference (V) between them. For example, a one-farad capacitor would store one coulomb of charge when one volt is applied across the plates. However, this charge cannot be put on the plates instantly. It takes a certain amount of time for the plates to charge. Examine the circuit below:

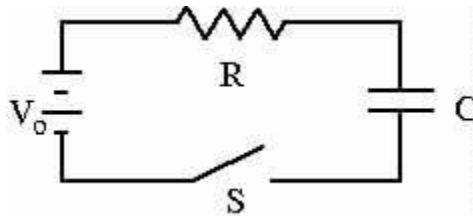

When you first throw the switch (S) which connects the battery to the capacitor, the voltage across the capacitor is not immediately equal to as the battery voltage. The charge moves onto the plates quickly at first, and the capacitor voltage increases quickly. However, as the capacitor becomes charged, the charging rate begins to taper off. Eventually, the capacitor voltage is the same as the battery voltage, and no more charge can be forced onto the plates. At this point, the capacitor is no longer charging.

If you analyze voltage of a charging of the charging capacitor over time, you might notice that it models an inverse exponential curve. Incidentally, the following formula describes the charging of a capacitor over time:

$$V_C = V_B (1 - e^{-t/RC})$$

$V_C$  is the voltage across the charging capacitor at any time (t).  $V_B$  is the battery voltage, R is the resistance of the circuit, and C is the capacitance.

After a capacitor is charged, it will hold its charge even when the power supply is removed. The capacitor can now be used as a voltage source that stores charge until you need it to use

it. When a capacitor is used, it will discharge. Its rate of discharge will be great at first. However, that rate tapers off exponentially with time. Eventually, the voltage across the capacitor will be near zero, at which time the capacitor is no longer discharging. Below is an example of a circuit that will discharge a capacitor:

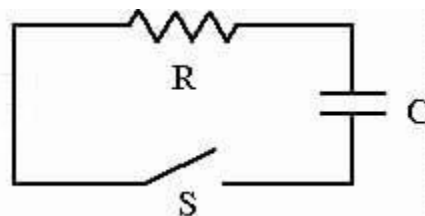

If you analyze the voltage of a discharging capacitor over time, you might notice that it models a natural exponential curve. Incidentally, the following formula describes the discharging of a capacitor over time:

$$V_C = V_B (e^{-t/RC})$$

### PRELAB QUESTIONS (to be checked off at the beginning of lab)

1. According to the above inverse exponential (charging) equation, what does  $V_C$  equal when  $t = 0$ ? What about when  $t$  approaches infinity? Explain.
2. According to the above natural exponential (discharging) equation, what does  $V_C$  equal when  $t = 0$ ? What about when  $t$  approaches infinity? Explain.
3. According to the charging and discharging equations, what would be the effect of changing  $R$  or  $C$ ? For example, if you doubled  $R$  or  $C$ , how would that change the graph?

### MATERIALS

- Battery
- Resistors and Capacitors
- Wires and connectors
- Switch
- Vernier Differential Voltage Probe
- Multimeter
- Vernier Lab Pro or GO! Connector

### ACTIVITIES

#### Activity 1: Modeling charge and discharge of a capacitor

You will use the Vernier voltage probe to measure the charge and discharge of the capacitor. Connect the probe to the computer and open Logger Pro. To "zero" the probe, connect the ends of the probe together and press "ctrl-0". Logger Pro should display a readout of very close to zero.

Begin by discharging the capacitor (see below). The discharging circuit for the capacitor is very simple. A capacitor is discharged simply by connecting the ends together with a conductor. Leave it connected for about 10 seconds to make sure it is completely discharged.

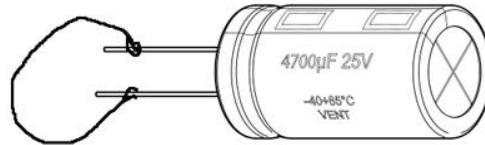

In the above discharge, resistance will be effectively zero, and the time constant will be very short. Placing a resistor in the loop will slow the current, increasing the amount of time it takes to charge and discharge. This is important because you are going to analyze these charge and discharge curves.

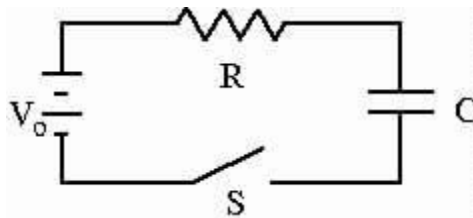

Now construct the RC circuit above using the resistor and one of the capacitors on your table, but do not connect the battery yet! Do not twist or bend the wires of the resistor or capacitor; use the alligator cables to make the connections. **Make sure that the negative end of the capacitor is going to connect to the negative end of the battery! If you don't, the capacitor might overheat and explode!** Do not close the switch yet. Attach the voltage probe so that it will measure the voltage across the capacitor. Ask your instructor to check your circuit.

When you have received permission from your instructor and the circuit is complete, click "collect." You may now close the switch. You should see the charging curve of the capacitor voltage.

After the capacitor is fully charged, you may disconnect the battery and discharge the capacitor using the circuit below.

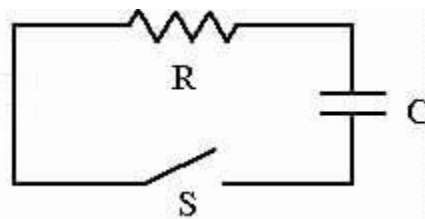

When the circuit is constructed, press the switch and discharge the capacitor while Logger Pro is collecting.

With a little practice and some adjustment of the time and voltage scales, you should be able to charge and discharge the capacitor during one collection cycle, so that both curves are displayed, one after another, on the same graph.

Examine the equation that models the voltage of a charging capacitor, then use the curve fitting function of Logger Pro to apply that equation to the charging portion of the graph. Next examine the equation that models the voltage of a discharging capacitor, and use the curve fitting function of Logger Pro to apply that equation to the discharging portion of the graph. Print this graph.

Repeat for the second capacitor. Be sure to keep track of which capacitor was used for each graph! You will need this information for Activity 2.

### Activity 2: Accurately determining capacitance

Although multimeters read resistance very accurately, most do not have the capability to read capacitance. Compounded with the fact that capacitors are very loosely labeled (easily varying by 25% in many cases), it is very hard to know to any good precision what the actual value of your capacitor is. In this activity you will examine charge and discharge graphs in order to accurately calculate the capacitance.

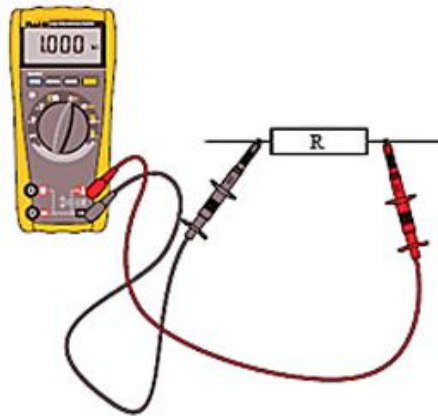

First, use the multimeter on the "Ohms" setting to measure the value of the resistance (see above). **Make sure the battery is not connected!**

For this activity, only the discharging curve of each capacitor will be analyzed. This is because the charging circuit contains not only the resistance of the resistor which you measured, but also the internal resistance of the battery, which you did not measure.

Examine the discharge equation used in activity 1, and compare it to your curve fit parameters to determine the value of the two capacitors. Using percent difference, compare these to the value that is actually printed on the capacitors.

### Activity 3: Capacitors in series and parallel

This activity examines the way in which capacitors combine in series and parallel. Before beginning this activity, rank the following three situations, in order of least to greatest capacitance. (Assume that the capacitors have the values found in Activity 2.) Your instructor must check off this prediction before you continue.

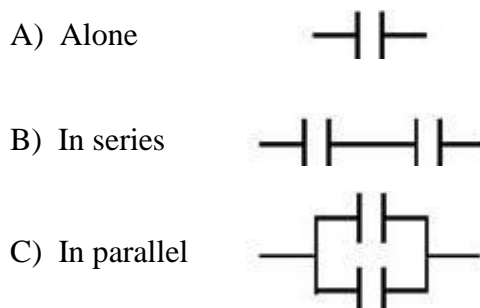

After you have made your predictions, repeat the Activity 2 experiment to determine the total capacitance of the two capacitors placed in series. Repeat for the parallel configuration. Were your predictions correct? Explain.

### POSTLAB QUESTIONS

1. Imagine you have an RC circuit in which the capacitor is fully charged to 12 V. The capacitance is  $10.0 \mu\text{F}$  and the resistance is  $3.0 \text{ M}\Omega$ . Using the discharge equation, create a theoretical voltage versus time graph which plots  $V_C$  of a discharging capacitor. Starting at  $t = 0$ , sample  $V_C$  once a second for 10 seconds. Plot in Logger Pro and print.
2. When adding capacitors in series,  $1/C_{\text{total}} = 1/C_a + 1/C_b$ . Using the values of the capacitors found in Activity 2, calculate their total capacitance when placed in series. Compare this to the series capacitance found in Activity 3 using percent difference.
3. When adding capacitors in parallel,  $C_{\text{total}} = C_a + C_b$ . Using the values of the capacitors found in Activity 2, calculate their total capacitance when placed in parallel. Compare this to the parallel capacitance found in Activity 3 using percent difference.
4. Using the value capacitance you determined for the first capacitor in Activity 2, use the **charging equation** to determine the resistance of the **charging** circuit. How does this resistance compare to the value of the resistor you measured with the multimeter? How can you use this information to make an inference about the internal resistance of the battery pack?
5. Do you find it strange that the units of the time constant is  $\Omega \cdot \text{F}$ ? Shouldn't a time constant have units of seconds? Use the following equations to show that an Ohm multiplied by a Farad is equal to a second!

$$\text{Voltage} = \text{Resistance} \cdot \text{Current}$$

$$\text{Charge} = \text{Capacitance} \cdot \text{Voltage}$$

$$\text{Current} = \text{Charge} / \text{time}$$



## QuickGuide to Magnetism

**CAUTION:** This lab uses powerful magnets. Do not allow these magnets to come within one foot of electronic equipment (flash drives, calculators, cell phones, wrist watches, etc.), credit cards, iron filings, or any other magnets!

Just as a mass is the ultimate cause for a gravitational field and a charge is the ultimate cause for an electric field, there is an “ultimate cause” for a magnetic field. **Moving charges** *cause* magnetic fields. These moving charges can occur via currents in wires OR the moving charges inside atoms. The detailed behavior of the magnetic field will depend on the “geometry” of the situation, that is, the arrangement of the moving charges.

When dealing with gravitational fields, we have only dealt with one geometry: a sphere of mass (ie, the Earth). This produces a gravitational field that follows an inverse square law ( $g = GM/r^2$ ). When dealing with electric fields, we have looked at point charges (inverse square behavior) and sheets of charge/capacitor (uniform field independent of distance). Other geometries are possible (cylinder, sphere, dipole, etc.), each with their own dependence on distance.

The same is true for magnetic fields. Depending on the geometry (how the moving charges are arranged), the magnetic field can be dependent on  $r^x$  where  $r$  = center-to-center distance between the object causing the magnetic field and the place where the magnetic field is measured. Or, it can be independent of distance, as in the inside of a solenoid, or Helmholtz coil. In addition, the magnetic field can behave differently depending on *where* you examine it. For instance, a cylindrical magnet has a strong magnetic field along the axis (point P in the diagram) of the magnet that depends on  $(r_{\text{on-axis}})^{-3}$ . However, the magnetic field along the side of the cylinder (point S in the diagram) could fall off as  $(r_{\text{off-axis}})^{-1}$ , depending on how the magnet is manufactured. The distance dependence of most magnets falls somewhere in between.

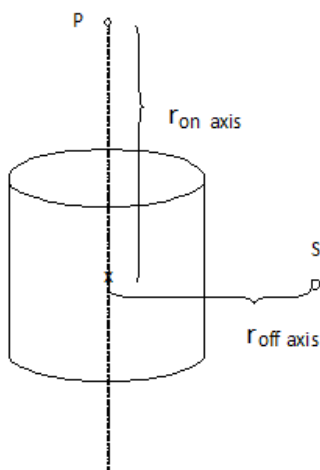

## LEARNING GOALS and OUTCOMES

- Experiment with magnetic fields
- Measure the distance dependence of magnetic fields

## MATERIALS

Various magnets	Vernier LabPro or Go! Link
LoggerPro	Vernier Magnetic Field Sensor
Small solenoid	Long solenoid
Plastic sheet	Iron filings
Power Supplies	Current-carrying Wire

## ACTIVITIES

### Activity 1 - Observing the field of a permanent magnet:

a) A cylindrical magnet has a pole at either end of it. Using a compass, determine the north end of your magnet. (Keep in mind that the arrow on a compass in the compasses north pole.) Move your compass around the magnet. Turn your magnet so that the north end is on the left. Make a sketch that predicts what the magnetic field lines of your magnet will look like and explain why your sketch looks as it does. Indicate the direction of the field as it goes from north to south.

After you have made your prediction, place your magnet under a piece of plastic and scatter iron filings on top. **Do not allow the magnet to come into contact with the filings!** The filings each act like a tiny compass. Sketch the orientation of the filings. How do the positions of the filings support your prediction?

b) A large horseshoe magnet is on the front desk. Use a paper clip on a string to determine the orientation of the magnetic field at various distances from the magnet. Make a sketch of your observations.

### Activity 2 - Observing the field of current-carrying wire:

a) There is a station at the front of the room that includes a current-carrying wire and a small compass. Turn the power on and use the compass to observe the magnetic field all around the wire. Sketch your observations, making note of the direction of the current and the direction of the magnetic field. Be sure to turn off the power supply when you are finished to prevent overheating!

Based on your observations, make a prediction on what the magnetic field would look like if the current were reversed. Draw a sketch and explain.

After you have made your predictions, reverse the current and use the compass to examine the magnetic field. Do your observations support your prediction? Explain.

b) On your table is a small solenoid. A solenoid is a series of wire loops. It can be thought of as a lot of current-carrying wires placed side by side. Based on your observations in 2a, make a prediction on the shape of the magnetic field inside and outside of the solenoid. Predict the direction of the current and the polarity of the magnetic field. Make a sketch and explain.

Power your solenoid with two D-cell batteries in series. Be sure to disconnect the battery when you finish to save power and prevent overheating! Use your compass to examine the shape and direction of the magnetic field around the solenoid. Make a sketch of your observations. Do your observations support your prediction? Explain.

Based on your observations, make a prediction on what the magnetic field would look like if the current were reversed. Draw a sketch and explain.

After you have made your predictions, reverse the current and use the compass to examine the magnetic field. Do your observations support your prediction? Explain.

How does the magnetic field of the solenoid compare to the magnetic field of the cylindrical magnet?

Activity 3 - Observing the distance dependence of a permanent magnet:

For the cylindrical magnet provided, measure the change in the magnetic field as a function of the distance from the center of the magnet. The largest flat surfaces represent the north and south poles. With the north pole facing the probe, measure the on-axis field of your magnet, orient the Magnetic Field Sensor so that it is perpendicular to the center of the magnetic pole. Refer to the activity in the Quickguide to the Magnetic Field Sensor for instructions on how to do this.

What power of  $r$  best represents the distance behavior for the magnet you examined? When you have generated a graph, and have determined the best fit for your data, use the curve-fit information to generate an equation that models the distance-dependence of your magnet along your selected axis.

Without deleting the previous data, repeat the experiment for the south pole, then again for the off-axis field of your magnet. Put all data sets on one graph, then print. How do the fields compare to each other?

Activity 4 - Observing the distance dependence the field of a solenoid:

a) Repeat activity 3 for the small solenoid on your table. Power the solenoid with two D-cell batteries in series. Be sure to disconnect the battery when you finish to save power and prevent overheating! Plot the distance dependence of the on-axis field.

b) Based on activity 2a, make a prediction about the magnetic field on the inside of a long solenoid. Make a sketch and explain your predictions.

A long solenoid is being passed around the room. Connect the solenoid to two D-cell batteries in series. Create a plot of magnetic field strength versus time that shows what

happens when you move the magnetic field sensor along the polar axis. Start several feet away from the north end, then travel slowly through the solenoid and out the southern end. Do your observations support your prediction? What can you conclude about the magnetic field of a solenoid?

## QuickGuide to the Vernier Magnetic Field Sensor



The Vernier Magnetic Field Sensor measures a vector component of the magnetic field near the sensor tip. The tip can be adjusted, allowing the user to measure fields that are parallel or perpendicular to the long axis of the sensor.

### How the Magnetic Field Sensor Works

The sensor uses a Hall-effect transducer. It produces a voltage that is linear with magnetic field. The sensor measures the component of the magnetic field that is perpendicular to the white dot on the end of the sensor tip. The reading is positive when the white dot on the sensor points toward a magnetic south pole. The switch on the sensor shaft is used to select the range. The 6.4 mT range is used to measure relatively strong magnetic fields around permanent magnets and electromagnets. Each volt represents 32 gauss ( $3.2 \times 10^{-3}$  tesla). The range of the sensor is  $\pm 64$  gauss or  $\pm 6.4 \times 10^{-3}$  tesla. The 0.3 mT range (marked high amplification in an earlier version of this sensor) is used mainly to measure the magnetic field of the Earth and very weak fields. It can be used for other magnets, but the sensor must remain in one position so that the reading is not affected by the background field of the Earth. Each volt represents 1.6 gauss ( $1.6 \times 10^{-4}$  tesla). The range of the sensor is  $\pm 3.2$  gauss or  $\pm 3.2 \times 10^{-4}$  tesla. If the sensor tube is held vertically with the tip horizontal, and rotated until the maximum voltage is found, the tip with the white dot will point to magnetic north. The magnetic inclination in Boone can be found by holding the tube so that the white dot is facing north, and rotating the sensor end of the tube down until the voltage reaches a maximum. The angle of the tip from vertical is the magnetic inclination. Note that the north pole of a freely suspended magnet points north, since the magnetic pole of the Earth in the northern hemisphere is a south magnetic pole.

### Activity: Measuring the strength of a magnetic field

1. Set the Vernier Magnetic Field Sensor range switch to the higher range, then connect it to the Vernier LabPro or the Vernier Go! Link connector. Connect it to the PC using the USB port.
2. Open Logger Pro. If the sensor is not automatically detected, click the 'Lab Pro' button. A picture of the interface box will appear. From the lists of sensors, find the Vernier Magnetic Field Sensor and drag it to the button that represents the appropriate slot. Close this window.
3. Under the "Experiment" menu, choose "Data Collection." This brings up the Data Collection window. Under "Mode," select "Events with Entry" instead of "Time Based." Rename the horizontal "Entry" axis as "Distance," with units of meters.
4. Close this window and click "collect." A "Keep" button should appear to the right of the "collect" button. As you move the sensor toward the magnet, notice how the field value (in the lower left-hand corner of the monitor) changes. If you get too close to a strong magnet, the sensor will become saturated, and the data will be invalid.
5. Place the Magnetic Field Sensor some distance from a magnet and click "Keep." You will be prompted to enter the distance. As you move the Magnetic Field Sensor away from the magnet, plot the field strength, in milliTeslas, versus the distance. Click "Stop" when you are done.
6. Based on the geometry of the magnet, the strength of the magnetic field diminishes with some power of the distance, usually between  $r^{-1}$  and  $r^{-3}$ . Fit a power curve to the data using the "Automatic Curve Fit" function under "Analysis."
7. To plot the field of another magnet on the same graph, click "collect" again, then select "Store Latest Run" when prompted.

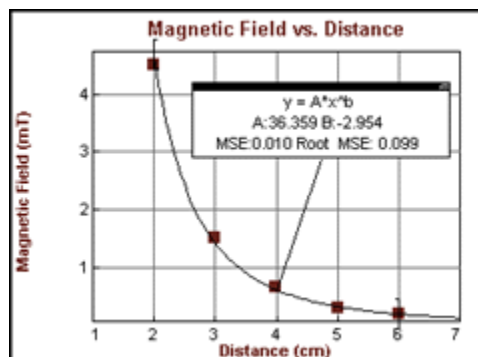

## Quick Guide to Electromagnetic Induction

We have seen that a potential difference applied to a wire will cause an electric current to flow through that wire. We have also seen that a current flowing through a wire creates a magnetic field. At the heart of the phenomenon known as electromagnetic induction is the idea that we can use a changing magnetic field (or, more accurately, a changing magnetic flux) to induce an electric current in a nearby wire.

Symbol for magnetic flux:  $\Phi_B$

A changing magnetic flux will induce a changing electric field ( $\epsilon$ ).

$$\epsilon = -d\Phi_B / dt$$

If a conductor is present, the electric field induced by the changing magnetic flux will induce a current to flow through the conductor. This is called *Faraday's Law of Induction*.

Last week we observed the magnetic field around a current-carrying wire. If a changing magnetic flux induces an electric field which causes current to flow in a nearby conductor, this conductor will also have its own magnetic field. It is now called an electromagnet.

*Lenz's Law* states that the induced magnetic flux is going to be in the opposite direction of the changing magnetic flux that created it.

### **Prelab Activity:**

Examine the following java application:

[http://phet.colorado.edu/simulations/sims.php?sim=Faradays\\_Law](http://phet.colorado.edu/simulations/sims.php?sim=Faradays_Law)

Write a paragraph detailing your observations.

### **Activity 1: Faraday's Law**

Last week we observed the magnetic field of a solenoid. To refresh, power your small solenoid with one battery and use a compass to determine the orientation of the magnetic field. Be sure to note the polarity of the battery!

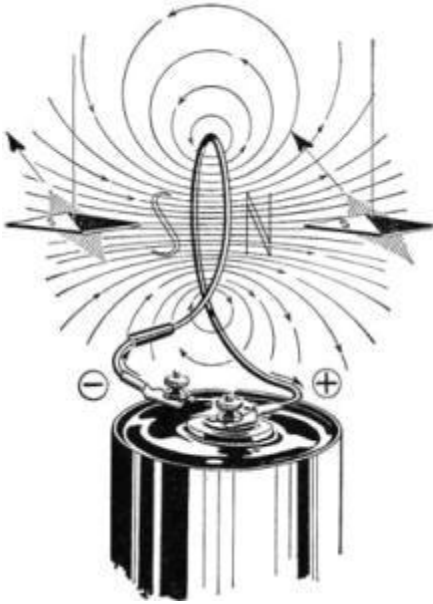

Now remove the battery and place the voltage probe across the terminals of the solenoid. Make sure that the + side of the voltage probe is on the same terminal as the + side of the battery!

Using Faraday's Law, predict what will happen when you bring the north end of your magnet up to the coil along the polar axis toward the end of the solenoid that produced a north pole when it was powered. (In other words, your magnet is in the opposite direction of the solenoid field created by a positive voltage.) Use Lenz's law to add direction to your prediction. Explain your prediction.

Test your prediction using Logger Pro. Were you correct? If not, modify your prediction.

Predict what will happen when you pull the north end of the magnet away from the solenoid along the polar axis? Explain your prediction, then test it.

Predict what will happen if you repeat the experiment on the other side of the solenoid. Explain your prediction, then test.

Predict what will happen if you repeat the experiment using the south pole of the magnet. Explain your prediction, then test.

### Activity 2: A change in flux

$$-\varepsilon dt = d\Phi_B$$

Now integrate both sides of the equation:

$$-\int \varepsilon dt = \Delta\Phi_B$$

This shows that the total change in magnetic flux is equal to the negative integral of the electric field versus time. The electric field is measured using the voltage probe. Connect the voltage probe to the small solenoid. Insert the straw into the solenoid and drop the magnet through. Note the orientation of the solenoid and the magnet.

Record your observations using Logger Pro. Integrate the voltage with respect to time (i.e., find the area under the curve) to determine the change in magnetic flux and print the graph.

NOTE: In order for this to work, the probe must be zeroed. Sometimes even that doesn't work because there is an offset to the voltage when the probe begins acquiring data. To account for this, you must find the average of the offset and then create a new calculated column of data which subtracts out the offset. Call this column "adjusted potential" and plot it against time.)

What is the total change in magnetic flux? What happens if you reverse the magnet? What happens if you reverse the polarity of the voltage probe? What happens if you tape two magnets south-to-north and drop them through? North-to-north? Explain your observations in terms of Electromagnetic Induction.

### **Activity 3: Magnetic Force**

3a. Although you may not have noticed it, your magnet slowed down a bit as it fell through the coil. Observe this effect more strongly by dropping a large magnet through a thick aluminum pipe. Use Faraday's Law and Lenz's Law to describe what happened.

3b. Predict what will happen when you power the large red electromagnet while an aluminum conducting ring is around it. Explain your predictions in terms of Faraday's Law and Lenz's Law. Test your predictions.

3c. Predict what will happen when a large electrical current passes through a coil that is surrounding a conductive aluminum can. Explain your predictions in terms of Faraday's Law and Lenz's Law. Your instructor will test your predictions. After the demonstration, examine the can. What can you infer about the direction of the magnetic field? What can you infer about the direction of the current flowing in the coil? Draw a sketch to explain.

### **Activity 4: Lorentz Force: Magnetic force on a current-carrying wire.**



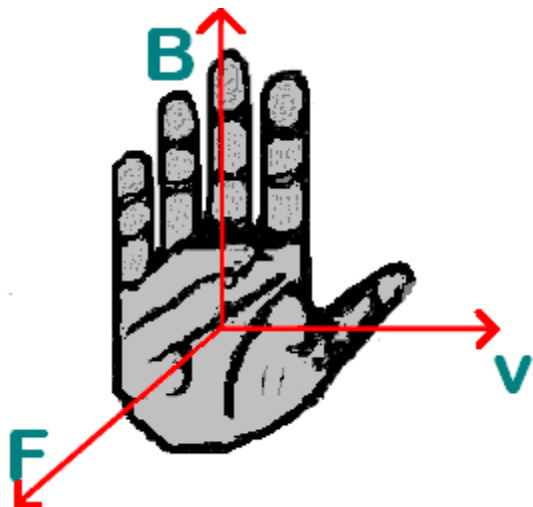

A magnetic field will exert a force on a moving charge. This is called the Lorentz force. A wire carrying electric current has many moving charges in it. For a current-carrying wire in a magnetic field, the magnetic forces on the individual moving charges add up to produce a net magnetic force on the wire. Examine the diagram above.  $v$  represents conventional current flow (+ to -),  $B$  represents the direction of the magnetic field (N to S) and  $F$  represents the force that the magnetic field exerts on the current-carrying wire.

2a. Predict what will happen when you push your magnet through a powered solenoid whose magnetic field is oriented in the same direction. Now predict what will happen when you push your magnet through a powered solenoid whose magnetic field is oriented in the opposite direction. Explain your predictions.

Power your solenoid with three batteries (4.5 V). Note the direction of the magnetic field and the direction of current. Orient your magnet the same direction and push it into the coil. Was your prediction correct? Now try reversing the magnet. Explain what happens. What happens if you reverse the direction of the solenoid current? Explain your observations using the Lorentz Force.

2b. Examine the pipe in the permanent magnet. Briefly cause current to flow through the pipe and record your observations. What happens when you reverse the current? Try to determine the direction of the magnetic field. Explain how you did this. Once you have written down your explanation, check your prediction with a compass. Explain any differences.

### Activity 5: Induction Cooking

Examine the induction cooker. Using what you know about induction, explain how such a device might work (hint: read about Joule Heating).

### Activity 6: Transformers

Position a coil of wire attached to a light bulb above the large red electromagnetic. Briefly power the electromagnetic using the foot switch and record your observations. Using what you know about induction, explain how this works.

# Quick Guide to Properties of Light

## Introduction

Consider a radiating light source, for example a light bulb. The property of the light that describes its brightness is called the *luminous flux* ( $F$ ), which is measured in *lumens* (lm). Although the luminous flux is a constant, the perceived brightness of a light diminishes with distance. This is because the luminous flux is evenly distributed throughout three dimensions. Imagine that you place the light at the center of a sphere that has a radius ( $r$ ), and the light is evenly distributed over the entire surface. As the radius of the sphere increases, the surface area increases with the square of the radius, and so the perceived brightness diminishes at the same rate. This is called the *inverse square law*. The perceived brightness is called the *illuminance* ( $E$ ), and its unit is the *lux* (lx). Illuminance is the luminous flux incident on a surface, divided by the area of that surface.

Another way to gradually diminish light is to send it through semi-transparent filters. As light travels through a filter, the resulting illuminance ( $E$ ) decreases with filter thickness. This is due to absorption and scattering of the light by the molecules present in the filter. The property of the filter which determines what percentage of light will pass through is called the transmission coefficient ( $t$ ), and is a constant between 0 and 1. The illuminance which actually makes it through the filter is a factor  $t$  (which stands for *transmission coefficient*) of the initial intensity ( $E_0$ ) of light entering the filter.

For example, if a filter has a transmission coefficient  $t = .80$ , then light entering the filter with an illuminance of 50 lx will exit the filter with an illuminance of  $(50 \text{ lx})(.80) = 40 \text{ lx}$ . What happens if we use two filters with transmission coefficients  $t = .80$ ? Since the illuminance is being factored twice by  $t$ , the light has been reduced by a factor  $t^2$ :  $(50 \text{ lx})(.80)(.80) = 32 \text{ lx}$ . If this logic is followed, we find the following:

Therefore,  $t$  is a negative exponential function of the length of the light path through the filters. It is modeled by the following formula:

$$E = E_0 e^{N \ln(t)}$$

## Apparatus

Vernier light sensor	LabPro interface
Stand and assorted clamps	7.5 W light bulb, socket and cord
Colored filters	Meter stick

## Activity 1: Inverse Square Law

Complete the activity found in the QuickGuide to the Vernier Light Sensor.

## Activity 2: Lambert's Law

Set up your graph to register *Events With Entry*, with the number of filters (N) on the x-axis. Show that as you place filters between the source and the sensor (don't change the distance!), illuminance diminishes at a natural exponential rate.

### Questions

1. How do we know that the value of the transmission coefficient  $t$  is always less than one?
2. Use the natural exponential curve fit to determine the transmission coefficient of your filters.

## QuickGuide to the Vernier Light Sensor



The sensor is a photodiode. It produces a voltage which is proportional to light intensity. The spectral response approximates the response of the human eye. The switch on the box is used to select the range. If the reading from the sensor reaches the maximum for the selected ranges, you need to switch to a less sensitive range. If the reading is very small or 0, you need to select a more sensitive range.

- The 0-600 lux range is the most sensitive range, and is useful for low levels of illumination.
- The 0-6000 lux range is a good general purpose range for indoor light levels.
- The 0-150,000 lux range is used mainly for measurements in sunlight.

### **Activity: Observe how illuminance diminishes with distance from the light source.**

Plug the Vernier Light Sensor into the LabPro. Power up the LabPro and connect it to the PC. Open Logger Pro. If the sensor is not automatically detected, click the 'Lab Pro' button. A picture of the interface box will appear. From the lists of sensors, find the Vernier Light Sensor and drag it to the button that represents the appropriate slot. Once the sensor has been located, click the white square labeled CH1. Under the list of *Current Calibrations* select *Light 600 lux*. Check your Vernier light sensor box to make sure the three-way switch is set to the *600 lux* range. You should see the real-time value of the sensor dynamically displayed in the CH1 box. If all is working, close the Sensors window. Under the *Experiment* menu select *Data Collection*. Change the *Mode* to *Events With Entry*. This is so you can collect data from the sensor at discreet distances. For *Column Name*, enter 'r'. For Units, enter 'm'. Click *Done*. Position the light bulb approximately .1 m directly above the Vernier light sensor, measured from the top of the sensor the center of the bulb. Be careful not to damage

the sensor! Make your measurement in meters, to the nearest .001 m. Click the *Collect* button at the top of the screen. With the meter stick out of the way of the sensor, click the *Keep* button. The *Events With Entry* window will pop up. For 'r', type in the distance you just measured. Record your data! As you move the Light Sensor away from the bulb, plot the illuminance versus the distance. Use the automatic curve fit function to show how that the light diminishes with the inverse square of the distance.

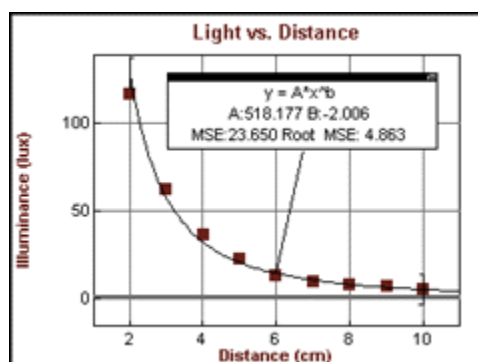

## QuickGuide to Snell's Law

### Purpose

To calculate indices of refraction by measuring angles of incidence and refraction, to study critical angle, and to measure the angle of minimum deviation.

### Apparatus

Laser with cylindrical lens  
Glass prism and cube  
Protractor

### Introduction

The index of refraction is defined as the ratio of the speed of light in a vacuum to the speed of light in a medium. As light enters a medium in which the speed is less in the second medium, the rays are refracted (bent) toward the normal.

Snell's Law states that  $n_1 \sin(i) = n_2 \sin(r)$  where  $n_1$  is the index of refraction of medium 1 (air in the figure below) and  $n_2$  is the index of refraction of medium 2 (glass). The index of refraction is a unitless value, and  $n_{\text{air}} = 1.00$ .

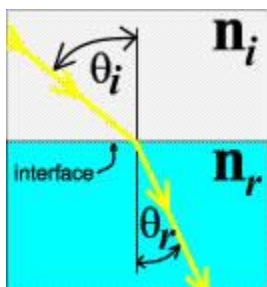

### Activity 1: Measuring the index of refraction of a cube

Adjust the laser lens to produce a line of light on a sheet of paper taped to the table. Place the glass cube, painted side down, at some angle and outline its position. Trace the ray through the cube and measure the angles of incidence and refraction. Calculate the index of refraction of the glass. For greater accuracy, do this for three or more angles. Also try arranging the light so that it enters perpendicular to the surface to the glass. What type of result does this give?

What is the mean value of the index of refraction? What is the standard deviation (SD) of the data? Are all your measurements within one SD of the mean?

### Activity 2: Finding the index graphically

Take another look at the Snell's Law equation. It can be restated  $\sin(i) = (n_2/n_1) \sin(r)$ , which

is in the form  $y = mx$ . In Activity 1 you gathered data by varying  $\sin(i)$  and  $\sin(r)$ . If you plot these variables against each other, a graphical analysis should give you information about the ratio of  $n_2/n_1$ . Plot the graph and determine the index of refraction of the glass. To insure a broad range of angles, include the scenario in which the light enters perpendicular to the surface of the glass.

### **Activity 3: Prism**

Repeat the previous activities using the glass prism.

### **Questions**

Compare and contrast the methods of finding the index of refraction found in Activity 1 and Activity 2. Which is preferable? Can you think of situations where one method would be favored over the other?

## QuickGuide to Lenses

### Purpose

To investigate methods for determining the focal length of lenses, and to determine magnification:

### Apparatus

Meter stick with lens and screen holders and a cardboard screen

Optical bench with sliding object, lens and screen holders

Converging lens

Translucent optical screen

Object with light source

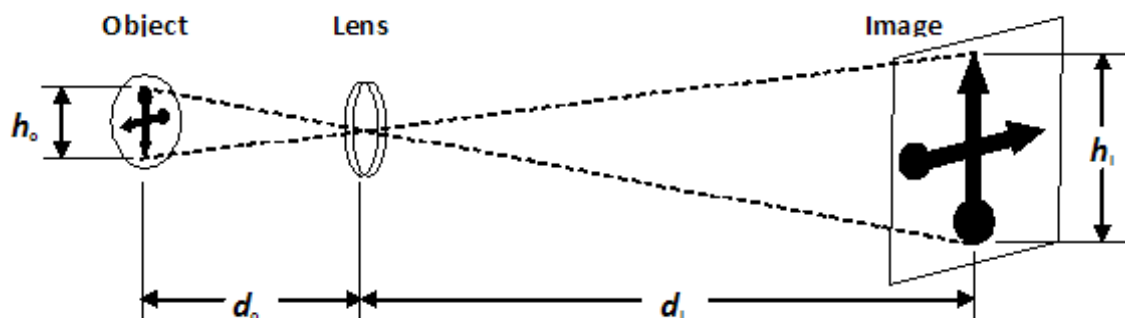

Figure 1

### Introduction

The focal length ( $f$ ) of a converging lens can be found using the following equation:

$$1/f = 1/d_i + 1/d_o$$

where  $d_o$  is the distance between the object and the lens and  $d_i$  is the distance between the lens and the focused image (see figure 1).

The ratio of  $d_i$  to  $d_o$  is the linear magnification, which is also the ratio of  $h_i$  to  $h_o$ .

### Activities

Determining the focal length of your lens:

1. Before moving to the optical bench, let's start with a quick and dirty method of determining the focal length of the lens. Take your converging lens out into the

- hallway near some windows. Stand by the wall across from the windows. Move your lens back and forth near the wall until you see an image of the outside buildings on the wall. Describe the image compared to the object.
2. Get a focused image on the wall and measure the distance from the lens to the wall. Is this distance  $d_i$ , or  $d_o$ ?
  3. The outside buildings are MUCH further away from the lens than the image is. Estimate the distance to the buildings. Is this distance  $d_i$ , or  $d_o$ ?
  4. Using equation 1 above, determine the focal length of your lens.
  5. Now, what if your estimation for  $d_o$  above was wrong? Double your original estimation and recalculate the focal length.
  6. Why was estimating the distance from the lens to the outside buildings an accurate way to find the focal length? Explain, and also show this mathematically using the lens equation.

### Studying a Real Image:

1. On the optical bench, put a lens between the light source (object) and the translucent screen (image). The distance between the light source and the screen should be three to five times the focal length of your lens. Find a lens position that results in a large, focused image.
2. Draw a ray diagram of the situation. You may use your book or an online source for assistance.
3. Determine  $d_i$  and  $d_o$ , and also  $h_i$  and  $h_o$ . Calculate the focal length using the lens equation.
4. Is this focal length the same as the one you found using the outside buildings? Calculate the percent difference between these two values.
5. Determine the linear magnification two different ways (see introduction). Calculate the percent difference between these two values.

Find the lens position that results in a small, focused image, and repeat the parts 2 - 5. The linear magnification will be different, but the focal length should be unchanged. Using percent difference, compare this focal length to the focal lengths you determined earlier.



# Quick Guide to Atomic Spectra

## Introduction

The electromagnetic spectrum is the range of all possible frequencies of electromagnetic radiation. The electromagnetic spectrum extends from below frequencies used for modern radio to gamma radiation at the short-wavelength end, covering wavelengths from thousands of kilometers down to a fraction of the size of an atom. In principle the spectrum is infinite and continuous.

The "visible spectrum" is that small part of the electromagnetic spectrum that our eyes respond to. We typically can detect wavelengths ranging from 400 nm to 700 nm. When the entire visible band bombards our eyes at once, we see it as white light. However, we can use a device such as a diffraction grating to spread out, or disperse, white light so that we can see all the colors it contains.

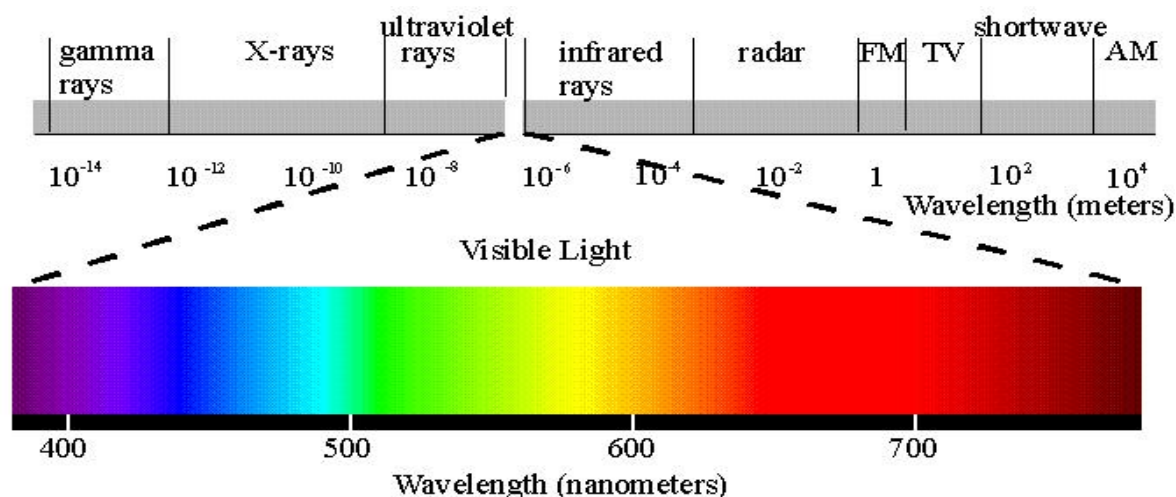

Where does light come from? The light we see originates from atomic emissions. Before light can be emitted, the electrons of an atom must first be excited into a higher energy state. This is done generally with heat, or with a high voltage. Once the electrons receive this energy, they don't keep it for long. And when they drop back down to a lower energy state, that energy has to go somewhere. It is emitted in the form of a photon. The greater the energy drop, the shorter the wavelength of light.

Now for something very interesting... As it turns out, electrons can't just have any amount of energy. They can only contain certain exact amounts of energy, depending on which atom they are surrounding. These energy states are labeled  $n=0$  (the ground state),  $n=1$ ,  $n=2$ ,  $n=3$ , and so on. For example, an electron surrounding a helium atom must exist at a totally different set of energies than an electron surrounding a hydrogen atom. It is important to note that  $n=2$  for hydrogen is not the same energy state as  $n=2$  for helium.

Because these atoms can only undergo specific energy drops, the photons they release will be at a predictable wavelength or color. Each atom has its own discrete set of colors that it can emit, and that set of colors is called its atomic line spectrum. Fortunately, the light from the sun is coming from many different types of atoms, each containing its distinctive set of colors, and when mixed together, the result is white light. However, when we isolate and excite one particular gas, we are able to identify it by the specific set of colors that it emits.

## MATERIALS

- H and He Spectrum Tubes
- Spectrum Tube power supply
- LoggerPro
- Marked string
- 2-meter stick
- HeNe Laser
- Diffraction Grating

## ACTIVITIES

### Activity 1: How a diffraction grating works

Let's make a large scale model of a beam of light passing through a diffraction grating. Take two, 2 m lengths of string and mark a spot every 3 cm on each. Each of these dots will represent a wavefront, and the distance between dots is one wavelength ( $\lambda$ ). The distance "d" represents the distance between two grooves in a diffraction grating. Starting with a fixed "d," pull your string straight out with the ends together until you touch a wall (a distance L from the grating). Verify that there are the same number of "wavelengths" on each string (see figure below). This configuration represents constructive interference. The place where the strings touch the wall is called  $m=0$  because there is no difference in the number of wavelengths on each string. If the string was a beam of light, there would be a bright spot on the wall at  $m=0$ . Note the position of  $n=0$ . (The figure below is a top view.) Count the number of marks to verify that both strings have the same number of wavelengths.

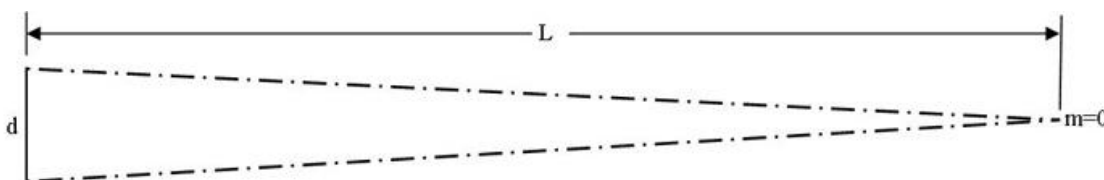

Next, begin to slide your hands across the wall, allowing the string to slide through your fingers as you go. At first, the marks on the string will get out of synch, or phase, with each other. This is because the string attached to the far side of "d" is getting longer than the other string. This represents destructive interference. If the string were a beam of light, there would be no bright spot along the wall.

Eventually, however, when you have slid a distance "D", the marks on the string will align again (see figure below). Why is this? Count the number of marks on each string and verify that the string attached to the far side of "d" has exactly one more wavelength than the other string. That is why this point on the wall is called  $n=1$ . If the string was a beam of light, there would be a bright spot on the wall at  $m=1$ , because constructive interference has once again been established.

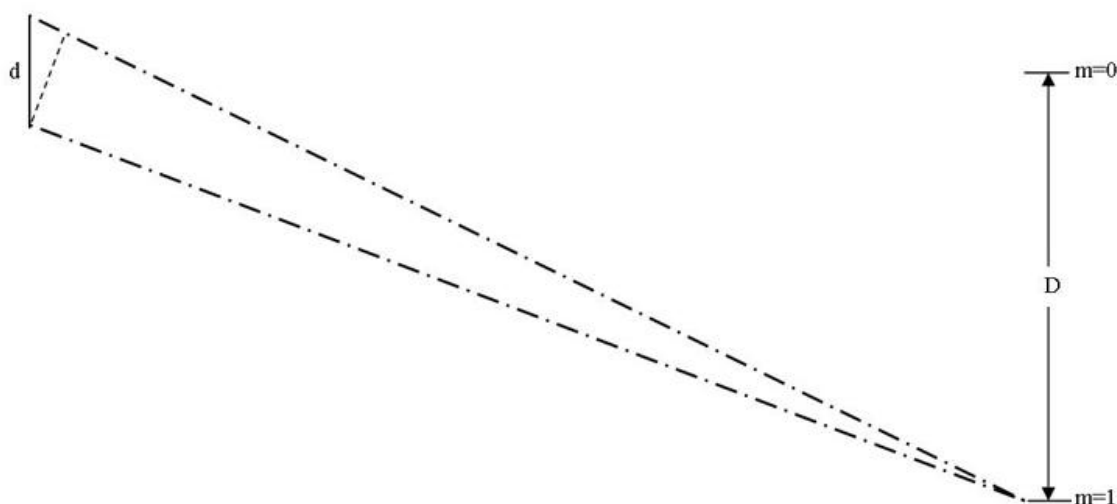

Below is a diagram of the end of the strings closest to the "grating". The angle between  $m=0$  and  $m=1$  is called  $\theta$ . It can be found from  $L$  and  $D$ . Notice that  $\theta$  forms a small triangle with "d" as the hypotenuse and one wavelength ( $\lambda$ ) as the opposite side. Come up with an equation that uses  $\lambda$  and  $\theta$  to solve for  $d$ . This is called the "grating equation." Measure  $d$  with the meter stick and compare it to your theoretical values using percent difference.

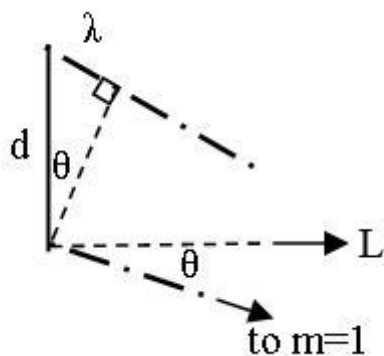

Starting at  $n=1$ , continue sliding your hands along the wall, and watch as the strings go out of phase and back into phase. Make note of the wall position when you once again have constructive interference (the marks are together again). If this were a beam of light, you would have another bright spot on the wall, and it would be called  $m=2$ . This is because the string attached to the farther end of "d" is now exactly two wavelengths longer than the other string.

Now the side of the triangle opposite of  $\theta$  is  $2\lambda$ , and not just  $\lambda$ . Once again, use  $d$  and  $\theta$  to calculate  $\lambda$ . Is your value correct? Make a sketch of everything you did in activity 1. How would your sketch look different if the marks on the strings were closer together (shorter wavelength)?

### Activity 2: Using real light!

In activity 3 we are going to use a real grating to determine wavelengths of light, but first you'll need to know what "d" is for your grating. Fortunately, we have a Helium-Neon (HeNe) Laser that has a fixed wavelength of 633 nm. Repeat the experiment in activity 1, except using real light. To do this, you'll need to pass the laser beam through the grating and look for patterns of constructive interference on the wall. Determine "d" for your grating. (Even though it's on a much smaller scale, it can be done the same way as in activity 1.)

Calculate "d" for your grating using  $m=1$ ,  $m=2$ , and even  $m=3$  if you can see it, on both sides of the  $n=0$  bright spot. Use these values to find an average value of "d" for your grating. More grooves generally indicate a better diffraction grating. How many grooves per centimeter does your diffraction grating have? Make a sketch of everything you did in activity 2. How would your sketch be different if you had used a green laser instead of a red one?

For a fixed grating distance, what is the relationship between wavelength and  $\sin \theta$ ?

The white light from the sun is actually made of a mixture of many different colors. To verify, use your grating to look at the fluorescent lighting, which is very similar to sunlight. Using what you have learned in activities 1 and 2, explain how a diffraction grating splits that light up so that all the different colors can be seen.

### Activity 3: Finding the wavelengths of Hydrogen

In activity 3 we are going to use our diffraction grating to determine the wavelengths of Hydrogen. The visible photons of Hydrogen are emitted when electrons fall down to the second energy state ( $n=2$ ) from a higher energy state ( $n=3, 4, 5$ , etc.)

Insert the Hydrogen tube into the Spectrum Tube power supply. Next, set your diffraction grating at a fixed distance from the tube. Turn on the supply and dim the lights. Looking through the grating, you should be able to see the specific bands of color that identifies this gas as Hydrogen. Your partner will help you determine the distance from the center of each color band (look left AND right). Using the method detailed in activity 2, find the average wavelength of each visible band.

### Activity 4: Balmer's Formula

In the 1880's Johannes Balmer was challenged by a colleague to find a rule which would predict the spectrum of hydrogen, as the visible spectrum of hydrogen was accurately known at that time. Balmer discovered the following formula to predict the wavelengths of hydrogen:

$$\frac{1}{\lambda} = R \left( \frac{1}{2^2} - \frac{1}{n^2} \right)$$

where  $R = 1.097 \times 10^7 \text{ m}^{-1}$  and  $n = 3, 4, 5$ , etc. Use Balmer's formula to calculate the wavelengths of the visible spectrum of hydrogen, then compare them to your experimentally determined values using percent error.

#### Activity 5: Light speed with helium

Consider the equation  $\lambda = v f$ . If you were to plot the variables  $\lambda$  versus  $f$ , what type of graph would you expect? What would be the units of the slope?

Using the method detailed in activity 3, determine the wavelengths of the helium spectrum. Plot against the corresponding values of frequency found in the table below so that  $v$  is discovered in the slope. Compare this value to the accepted speed of light:  $3.00 \times 10^8 \text{ m/s}$ .

<b>Color of helium emission line</b>	<b>Accepted Frequency (Hz)</b>
red	$4.48 \times 10^{14}$
yellow	$5.11 \times 10^{14}$
green	$5.99 \times 10^{14}$
blue-green	$6.09 \times 10^{14}$
blue	$6.36 \times 10^{14}$
violet	$6.71 \times 10^{14}$

# QuickGuide to Radioactivity

## Purpose

To determine the half-life of a short-lived radioactive isotope Ba-137.

## Apparatus

Radiation Monitor	Mini-generator
LabPro interface	LoggerPro

## Theory

Radioactivity is a property of the nucleus. A substance is said to be radioactive if its nuclei exist in a form which is unstable; the nuclei spontaneously decay to a more stable form. When the nucleus of an atom undergoes radioactive decay it is giving up energy in the process. Sometimes several decay processes are necessary before a nucleus reaches a stable state. These processes may include the emission of alpha particles (He nuclei), beta particles (electrons), or gamma rays (electromagnetic radiation).

In this lab we will measure the rate of decay of Barium 137 which emits gamma rays as the nuclei make the transition from a metastable state to a stable state. The gamma activity ( $A$ ) will be detected using the radiation monitor. As the nuclei spontaneously decay, there is less and less Barium 137, and so the activity over time,  $A(t)$ , may be modeled using a natural exponential function, where  $\lambda$  is the decay constant and  $A_0$  is the activity at the beginning of the measuring period:

$$A(t) = A_0 e^{-\lambda t}$$

The time required for the number of radioactive atoms to decrease to half the original number is defined as the *half-life* ( $T$ ). At this time,  $A = 1/2A_0$ .

**CAUTION:** As usual, eating and drinking are not allowed in lab. This is especially important in lab today because of the presence of a radioactive substance. Don't be *afraid* of your radioactive sample, but do be careful with it! If you happen to spill the liquid, please notify an instructor. If you spill it on your hands, wash them. If you spill it on the table, don't try to clean it up -- ask your instructor!

## Procedure

1. Turn on your computer and open Logger Pro. Turn on the radiation monitor.

2. Under the *Experiment* menu, choose *Show Sensors*. Click the white square labeled Dig/Sonic 1 and select *Choose Sensor*. From the drop-down list, select *Radiation* and click *OK*.
3. Under the *Experiment* menu, choose *Data Collection*. Set *Seconds per Sample* to 30 seconds, and the *Run Time* to 600 seconds (10 minutes).
4. Click *Collect* and let the counter take a background run for the full 10 minutes.
5. Under the *Analyze* menu, choose *Statistics*. This will give you the mean background count per time interval (probably less than 30 counts per 30-second interval). Record this value onto your data sheet.
6. Obtain a radioactive sample from you instructor.
7. Click *Collect*. The background data may now be deleted. Let the counter take data for 10 minutes.
8. When the data collection has finished, create a new column by selecting *New Ccalculated Column* under the *Data* menu. Name this column "Radiation minus background." In the equation field, subtract the mean background count from the radiation data. Click *Done*. Plot the new column by clicking on the Y-axis of the graph and then select the new column.
11. Fit a natural exponential function to the data. Notice how this formula compares to equation (1).
11. Examine the parameters of the generic formula, then use that information, in conjunction with equation (2), to determine the half-life.
12. Use percent error to compare your experimental value of the half-life with the known value:  $T = 159$  s.

(9)

Create a new data column by selecting a new calculated column and create this column by dividing each data point in the counts per interval column by the first value in that column. Enter a new heading for this new column and then create yet another column by taking the  $\ln$  of this last column. As Eq (9) indicates that the first datum (i.e.  $A_0$ ) occurs at time  $t=0$ , generate a "new time" column which is the original time data minus 30s. Finally, graph the column  $\ln [A/A_0]$  versus "new time" and apply a curve fit. (What does Eq (9) suggest?) What is the significance of the slope? Use this new value of  $\lambda$  to determine a second (experimental) value for the half-life. Again find the % error. Does the accepted value fall within the uncertainty associated with this experiment value?

**PRECAUTIONS:**

1. As always, eating and drinking are not allowed in lab. This is especially important in this lab today because of the presence of a radioactive substance.

Don't be *afraid* of your radioactive sample, but do be careful with it! Don't spill the liquid. Once you're finished taking data, place your sample holder (with the sample) in the large beaker near the sink. If you happen to spill the liquid, please notify an instructor. If you spill it on your hands, wash them. If you spill it on the table, don't try to clean it up. Ask an instructor for assistance.

## QuickGuide to the Student Radiation Monitor



The Radiation Monitor consists of a Geiger-Mueller tube and rate meter mounted in a small, rugged, plastic case. The unit is battery operated and can be used without a computer for measurement of alpha, beta, and gamma radiation. It can be used to explore radiation statistics, measure the rate of nuclear decay, and monitor radon progenies.

### **Activity 1: Measuring the radioactivity of common household items**

Connect the 3.5 mm stereo jack end of the cable to the Radiation Monitor, then connect the white British Telecom end of the cable into DIG 1 on the LabPro. Power up the LabPro and connect it to the PC. Open Logger Pro. If the Radiation Monitor is not automatically detected, click the 'Lab Pro' button. A picture of the interface box will appear. From the lists of sensors, find the Radiation Monitor and drag it to the button that represents the appropriate slot. Close this window. Set the multiplication switch on the Radiation Monitor to 1X, then click 'collect.' Measure the radioactivity of the items in your bookbag. Acquire radioactive samples from your instructor and measure the amount of radioactive activity.

### **Activity 2: Measuring radioactive decay**

1. Turn on your computer and open Logger Pro. Turn on the radiation monitor.
2. Under the *Experiment* menu, choose *Show Sensors*. Click the white square labeled Dig/Sonic 1 and select *Choose Sensor*. From the drop-down list, select *Radiation* and click *OK*.



3. Under the *Experiment* menu, choose *Data Collection*. Set *Seconds per Sample* to 30 seconds, and the *Run Time* to 600 seconds (10 minutes).
4. Click *Collect* and let the counter take a background run for the full 10 minutes.
5. Under the *Analyze* menu, choose *Statistics*. This will give you the mean background count per time interval (probably less than 30 counts per 30-second interval). Record this value onto your data sheet.
6. Obtain a radioactive sample from you instructor.
7. Click *Collect*. The background data may now be deleted. Let the counter take data for 10 minutes.
8. When the data collection has finished, create a new column by selecting *New Calculated Column* under the *Data* menu. Name this column “Radiation minus background.” In the equation field, subtract the mean background count from the radiation data. Click *Done*. Plot the new column by clicking on the Y-axis of the graph and then select the new column.
11. Fit a natural exponential function to the data. Notice how this formula compares to equation (1).
11. Examine the parameters of the generic formula, then use that information, in conjunction with equation (2), to determine the half-life.
12. Use percent error to compare your experimental value of the half-life with the known value:  $T = 159$  s.

Create a new data column by selecting a new calculated column and create this column by dividing each data point in the counts per interval column by the first value in that column. Enter a new heading for this new column and then create yet another column by taking the  $\ln$  of this last column. As Eq (9) indicates that the first datum (i.e.  $A_0$ ) occurs at time  $t=0$ , generate a “new time” column which is the original time data minus 30s. Finally, graph the column  $\ln [A/A_0]$  versus “new time” and apply a curve fit. (What does Eq (9) suggest?) What is the significance of the slope? Use this new value of  $\lambda$  to determine a second (experimental) value for the half-life. Again find the % error. Does the accepted value fall within the uncertainty associated with this experiment value?

## BIOGRAPHICAL SKETCH

John Cockman is Director of Laboratories and Adjunct Professor in the Department of Physics and Astronomy at Appalachian State University in Boone, NC. He lives in Boone with his wife, Jennifer, and their two daughters, Arwen and Lorien. John also performs and teaches Appalachian fiddle.